



# Wildlife Crossings Guidance Manual

California Department of Transportation



## ***Prepared by:***

Robert J. Meese, Fraser M. Shilling, and James F. Quinn, Information Center for the Environment, Department of Environmental Science and Policy, University of California, One Shields Avenue, Davis, CA 95616. Under contract to the California Department of Transportation, Environmental Division; supervised by Amy Pettler.

Version 1.1 March, 2009

Acknowledgments: We appreciate the thoughtful reviews and suggestions of many Caltrans staff, especially Susan Leroy (District 1), Kally McCormick (District 7), Dave Hacker (District 5), Dan Whitley (District 2), Arianne Preite (District 12), Margaret Gabil (District 4), Margaret Lawrence (District 10-L), Robert James (District 11), Maureen Doyle (District 7), and Zack Parker (District 6), Rebecca Loeffler (HDR, Inc.), Elizabeth Chattin of the Ventura County Planning Department, U.S. Fish & Wildlife Service biologists Susan Jones, Jonathan Snyder, Ray Bosch, Karen Leyse, and Rocky Montgomery, Larry Vinzant, F.H.W.A., and Joe Vincenty, California Department of Fish & Game.

Cover photo: William Boarman, U.S.G.S.

# Table of Contents

1	What You Need to Know.....	1
1.1.	Introduction.....	1
1.1.1	Why Use This Manual.....	2
1.1.2	Who Should Use this Manual.....	2
1.1.3	How to Use This Manual.....	3
1.2.	Federal and State Wildlife Protection Laws.....	7
1.3.	Wildlife: Functional, Taxonomic, and Special Status Groups .....	12
1.3.1	Wildlife: Functional Groups.....	13
1.3.2	Wildlife: Taxonomic Groups .....	14
1.3.3	Wildlife: Special Status Species.....	14
1.4.	Special Habitats.....	15
1.5.	Sources of Species-Level Information.....	16
1.5.1	Internet Resources .....	16
1.5.2	Books.....	17
1.6.	Identifying Wildlife Crossings.....	18
1.6.1	Case Studies: Existing Efforts to Enhance Wildlife Crossing.....	19
	Existing Efforts in California.....	19
	Examples of Wildlife Crossing Projects Outside California .....	20
2	Baseline Assessment.....	21
2.1.	Basic Steps to Establish Your Baseline .....	21
2.1.1	Understanding Landscape-level Connectivity: Bioregional Perspective .....	22
2.1.2	Understanding Project-level Crossing Issues.....	24
2.2.	Developing Your Baseline for Wildlife Movement .....	25
2.2.1	Identify, Acquire, and Review Data Sources.....	25
2.2.2	Identify the Need for Additional Field Surveys and Assessments .....	26
	Establish Intended Outcome or Application of Survey Data.....	26
	Survey Site Selection.....	29
	Survey Sample Size .....	30
2.2.3	Survey and Detection Methods .....	31
	Visual (= Field) Observations.....	34
	Track-count Surveys .....	35
	Track Plates.....	35
	Raked Soil.....	36
	Live Traps .....	36
	Pitfall Traps.....	37
	Hair Traps .....	37
	Remotely-triggered Cameras .....	38
	GPS and Radio Collars .....	39
2.2.4	Required Expertise .....	39
2.2.5	Data Considerations.....	40
	Minimum Observation Data Set .....	40
2.3	Collaborative Approach .....	41
2.4	Use of GIS and Models to Predict Wildlife Passage .....	41

2.4.1	Large-scale Prioritization of Wildlife Crossing Corridors .....	42
2.5	Analyze and Interpret Data to Evaluate Crossing Potential .....	45
2.5.1	Areas of High Connectedness .....	45
2.5.2	Adjacent important conservation areas .....	45
2.5.3	Separation of seasonally-used habitats .....	45
2.6	Existing Connectivity Attributes/Infrastructure .....	46
2.7	Road-side Vegetation.....	47
2.8	Traffic Characteristics.....	47
2.8.1	Daily and Seasonal Rates of Crossing.....	48
2.8.2	Relative Visibility/Compromised Line of Sight .....	48
2.9	Identify Limitations of Baseline Data .....	49
3	Project Impact Assessment .....	50
3.1	Potential Temporary or Construction-Related Effects .....	51
3.2	Potential Direct and Indirect Effects .....	52
3.3	Changes/Effects to Existing and Potential Wildlife Crossing .....	52
3.3.1	Change in Infrastructure .....	53
3.3.2	Changes in Traffic Patterns .....	53
3.3.3	Changes in Visibility .....	53
3.4	Secondary Effects.....	54
3.5	Cumulative Effects .....	54
4	Selecting Avoidance, Minimization, or Compensatory Mitigation Measures .....	56
4.1	Project Types and Wildlife Crossing Considerations .....	56
4.2	Infrastructure Improvements to Wildlife Crossing.....	57
4.2.1	Wildlife Bridges/Overpasses .....	57
4.2.2	Wildlife Underpasses.....	58
4.2.3	Culverts .....	58
4.2.4	Fencing .....	59
4.2.5	Median Barriers.....	62
4.2.6	Signs .....	62
4.2.7	Lighting .....	63
4.2.8	Reflectors .....	63
4.2.9	Speed Bumps.....	63
4.2.10	Vegetation.....	63
4.2.11	Animal Detection Systems – Advanced Technology .....	64
4.2.12	Escape Ramps/One-way Gates/Median Barrier Gaps.....	64
4.3	Modifying Existing Infrastructure to Enhance Wildlife Crossing .....	65
4.3.1	Bridges and Overpasses .....	65
4.3.2	Culverts .....	65
4.3.3	Median Barriers.....	66
4.4	Choosing a Wildlife Crossing Improvement Measure.....	67
4.4.1	Which Structure or Action? .....	67
4.4.2	How to Size a Structure .....	68
4.4.3	Adjacent Functions and Uses.....	69
4.4.4	Spacing of Structures.....	69
4.5	Design Specifications.....	69
4.6	Identify Maintenance Needs .....	70

4.7 Costs .....	71
4.8 Post-project Monitoring and Adaptive Management .....	72
5 Keeping Informed .....	75
5.1 Internet Resources .....	75
5.1.1 Caltrans Resources .....	75
5.1.2 Federal Highway Administration Resources .....	75
5.1.3 Academic Institution Resources .....	75
5.1.4 International Conference on Ecology and Transportation (ICOET) .....	76
5.1.5 Other Wildlife Crossings-related Websites.....	76
5.2 Additional Information on Wildlife Survey Methods .....	77
5.3 Additional Mitigation Design Information.....	77
5.4 Recommended Reading .....	78
6 Literature Cited .....	79
6.1 On-line Resources Cited .....	88
7 Appendices.....	89
7.1 Definitions.....	89
7.2 U.S. Fish & Wildlife Service Recommended Specifications for Desert Tortoise Exclusion Fencing.....	90
7.3 Deer One-way Gate Design Considerations .....	95

## List of Figures

Figure 1: Wildlife Crossing Assessment Flowchart.....	3
Figure 2: Caltrans Wildlife Crossing Process Decision Tree.....	5
Figure 3: Caltrans Wildlife Crossing Project Decision Tree.....	6
Figure 4: Central Valley Wetland.....	14
Figure 5: Riparian corridor. Derived from U.S. Forest Service website.....	14
Figure 6: California Bighorn Sheep.....	18
Figure 7: Bear Crossing .....	20
Figure 8: Bioregions of California.....	22
Figure 9: Bear track .....	33
Figure 10: Schematic of a track plate box. ....	33
Figure 11: Installation of raked soil beds adjacent to US-93 in Montana (Montana DOT, 2006).34	
Figure 12: Medium Havahart live trap.....	35
Figure 13: Pitfall Trap.....	35
Figure 14: Barbed wire hair trap for bears.....	36
Figure 15: Remotely-triggered Camera .....	36
Figure 16: Culvert under rural paved road in the Sierra Nevada.....	44
Figure 17: Encourage use of native plants along roadsides (Caltrans photo).....	45
Figure 18: Motorist warning sign .....	45
Figure 19: Ecological "road effect" zone for birds. ....	52
Figure 20: Salamanders exiting culvert .....	55
Figure 21: Wildlife Underpass, Sierra County. Photo courtesy Brian Ehler, Calif. DF&G.....	56
Figure 22: Riparian culvert with rock ledge (derived from FHWA website) .....	57
Figure 23: Desert Tortoise barrier fence (William Boarman photo).....	57
Figure 24: Deer fence with "off-ramp".....	58
Figure 25: Median Barrier with gap. Caltrans photo. ....	60
Figure 26: Wildlife Warning Sign (derived from <a href="http://www.betterroads.com">http://www.betterroads.com</a> ).....	60
Figure 27: Culverts under I-15, San Bernardino county (Caltrans photo).....	63
Figure 28: State Hwy. 163 median barrier. ....	64

## **Index of Tables**

Table 1: Applicability of major federal and state wildlife regulations to wildlife crossings. ....	8
Table 2: Project types and potential crossing effects. ....	20
Table 3: Field assessment methods and most appropriate animal group(s) for each. ....	31
Table 4: Planning Process Stages and Relevant Questions to Consider .....	49
Table 5: Fencing attributes and considerations. ....	59
Table 6: Potential relative permeability of median barrier types to wildlife functional groups. ...	65
Table 7: Mitigation goals and wildlife size group-appropriate crossing structures. ....	66
Table 8: Preferred design specifications appropriate for functional species groups. ....	68
Table 9: Crossing Structure Materials Costs .....	69

# Preface

An estimated 15-20% of the United States is ecologically impacted by roads, and the many ecological effects of roads have recently been reviewed (Forman and Alexander 1998). Road ecology is an applied science that examines the interactions between roads and ecological systems and seeks both to document and understand the interactions and to reconcile the need for safe and effective transportation systems with the need to conserve the environment.

This Wildlife Crossings Guidance Manual is a literature-based guide on how to identify and assess wildlife crossings and includes a review of best practices. This manual is intended primarily for biologists, but planners and engineers may also find the manual useful. The manual reviews both the scientific and agency literature and uses case studies from within and outside of California to help to guide efforts to evaluate and avoid, minimize, or compensate for wildlife crossing conflicts. The manual also seeks to help Caltrans staff to meet regulatory requirements by integrating regulatory considerations in to the wildlife crossing evaluation process.

This manual is part of a larger Caltrans strategy to 1) catalog sources of information and knowledge about wildlife crossings, 2) generate, accumulate, and disseminate this information, and 3) develop guidelines for best practices and effective strategies to address road/wildlife conflicts.

## *Manual Goals*

- Identify off-the-shelf analyses and best practices from Caltrans projects, literature, experience, and related case-studies.
- Catalog sources of information that can help to avoid, minimize, or mitigate wildlife impacts.
- Provide aid in identifying and assessing effects to wildlife movement.
- Describe a systematic process that fits into the existing project delivery and planning processes.
- Initiate a system that may be used to collect and present Caltrans experiences in addressing wildlife crossing issues.

## *Manual Map*

**Section 1:** [What You Need to Know](#) (pages 1 to 19). A review of what you need to know to identify and assess wildlife crossings, including the regulatory considerations that affect transportation professionals.

**Section 2:** [Baseline Assessment](#) (pages 20 to 47). A review of what is needed to establish pre-construction (or baseline) conditions, including an assessment of wildlife groups, relevant field survey methods, data sources, management considerations, and modeling approaches.



**Section 3: [Project Effect Assessment](#)** (pages 48 to 53). A procedure to enable you to determine whether avoidance, minimization, or compensatory mitigation actions are necessary to facilitate wildlife movement and to meet regulatory requirements and public safety goals.

**Section 4: [Selecting Avoidance, Minimization, or Compensatory Mitigation Measures](#)** (pages 54 to 71). A review of procedures to select the best avoidance, minimization, or compensatory mitigation actions to meet regulatory or public safety requirements, including a review of structures that are most appropriate to facilitate movement by wildlife groups and meet wildlife crossing goals.

**Section 5: [Keeping Informed](#)** (pages 72 to 75). A review of wildlife crossings resources that are continuously updated to provide new strategies and applications, case studies, symposium proceedings, current literature citations, and additional sources of information relevant to transportation professionals.

**Section 6: [Literature Cited](#)** (pages 76 to 85). A listing of the literature and web resources used in the preparation of this document.

# Executive Summary

California's roads interact with wildlife in myriad ways, resulting in both public safety and conservation concerns. The Division of Environmental Analysis hopes that this Wildlife Crossings Guidance Manual will provide valuable guidance to biologists, environmental planners, transportation planners and engineers engaged in efforts to reduce the environmental effects of California's highway infrastructure while improving public safety. The manual describes a procedure to identify wildlife crossing conflicts, choose an effective avoidance, minimization, or compensatory mitigation strategy, and evaluate the results of mitigation actions. Steps in this procedure include:

- identifying wildlife crossing conflicts associated with projects
- determining whether special status species or habitats occur within a project's scope
- collecting data to document the occurrences and movements of wildlife species that may be impacted by a project
- interpreting and evaluating data to assess effects
- choosing the most effective avoidance, minimization, or compensation strategy
- evaluating the effectiveness of the mitigation action

This Executive Summary provides a brief overview of information essential to all engaged in transportation projects, including project managers, planners, engineers, biologists, and maintenance staff.

## ***What Are Wildlife Crossings & Why Do They Matter?***

Wildlife crossings are areas of concentrated animal movement intercepted by roadways. In most cases, effects are seen because animals are inadvertently hit by drivers as they attempt to cross the road surface, leading to mortality of animals (“road-kill”) and safety concerns to the motoring public. In other cases, animals choose to avoid crossing, and the roads present barriers to animal movement, dividing a formerly single population into two or more isolated population segments, causing a range of negative effects. These effects may be less apparent, but are no less significant. Further, environmental regulations compel transportation professionals to reduce or eliminate effects on special status species and habitats. Wildlife crossing considerations are reflected in the California Comprehensive Wildlife Conservation Strategy (California Department of Fish & Game, 2006), which lists wildlife habitat fragmentation as one of the biggest threats to the state’s wildlife and suggests as a solution that “*Wildlife considerations need to be incorporated early in the transportation planning process*”.

## ***Regulatory Considerations***

State and Federal regulations seek to protect wildlife and the habitats upon which it depends, and several of these regulations directly affect transportation professionals. For example, both the California Endangered Species Act (CESA) and Federal Endangered Species Act (ESA) require private and public organizations to limit harm to listed species and to consider and evaluate

cumulative effects; creating barriers to movement or increasing mortality to listed species may be considered harm or add to existing effects, thus mandating avoidance, minimization, or compensation. Although these and similar regulations may not explicitly describe roads or wildlife crossing, the avoidance of harm is explicit in these and similar efforts to protect wildlife species and their habitats.

### *Wildlife Habitat and Connectivity*

Habitat is defined as the part of the environment used by an organism and is essential for providing food, cover, and other requirements for survival. Agriculture, urbanization, and other human-caused effects subdivide habitats into habitat patches, and roads present barriers to many animals, impeding or preventing their movements among habitat patches. When considering wildlife movement, it is essential to consider the availability of habitat patches on both sides, and in some cases within the rights-of-way, of roadways and to attempt to reconnect habitat patches that may have been isolated by highway facilities. Considerations of cumulative effects may be especially relevant here, as effects due to transportation facilities may add to those due urbanization, agricultural development, and water management and directly affect special status species and/or their habitats.

#### *Project Managers, Engineers, & Planners*

SAFETEA-LU Section 6001 mandates that wildlife crossing and similar environmental considerations be taken into account early in the transportation planning process, thereby incorporating these concerns into project plans to enhance public safety while reducing impacts on special status species and reconnecting fragmented habitats. The Section 6001 assessment should be completed during Regional Transportation Plan development and will require good communication between wildlife experts and the Metropolitan Planning Organizations who are tasked with RTP development. Biologists should discuss what is known about wildlife crossing issues with MPOs, Project Managers, Engineers, and Planners as early as possible in the planning process.

### *Field Surveys Confirm Presence of Wildlife*

Wildlife crossing conflicts may be conspicuous, as when animal carcasses confirm mortality or public safety personnel document above-average rates of vehicle-animal collisions, or inconspicuous, as when animals refuse to cross a road bisecting a movement corridor and population segments become isolated. Confirming crossing conflicts requires effective assessment methods employed in a field survey. The methods to detect wildlife are well-developed, but field studies should be conducted by well-qualified individuals. Prior to conducting field work, one must accumulate existing information from agency reports and databases, maintenance personnel, other agency staff, NGO field staff and similar sources.

### *Project Managers, Engineers, & Planners*

Crossing roads is associated with normal daily or seasonal movements for many wildlife species, but for others, roads present physical barriers to movement. Resource agencies and biologists must identify wildlife movement patterns and transportation agency professionals must seek to understand the effects of roadways on these patterns. Public safety is of paramount concern with large-bodied animals on roadways, regulatory considerations compel actions to reduce or eliminate impacts on special status species, and the public may demand actions in regions of especially great animal mortality. Local actions taken to enhance the safe passage of animals help to restore habitat connectivity and benefits populations across a regional landscape.

### *Traffic*

Traffic characteristics (volumes, speeds, and timing) strongly influence wildlife crossings, although the relationships between traffic characteristics and wildlife crossing are complex. The highest volumes of traffic will impede or prevent crossing by many species, and road segments with the highest traffic volumes effectively serve as barriers to animal movement, while lesser volumes may increase rates of collision as animals attempt to cross the roads during intervals when cars are absent. There are daily and seasonal patterns in traffic and in animal movements and these patterns add to the complexity of the traffic/crossing relationship.

## ***Reducing Highway Effects on Wildlife Crossing***

The goal of this manual is to describe a procedure for assessing and responding to road/wildlife conflicts that minimizes the “ecological footprint” of roadways by enhancing wildlife crossing, reconnecting habitat fragments, reducing effects on special status species, and increasing public safety. Actions to reduce crossing conflicts take many forms, including project modification to avoid or minimize anticipated conflicts, modification of driver behavior, and the installation of structures to mitigate for effects.

### *Project Modification*

The best time to consider wildlife crossing issues is during initial project planning. If as part of the project planning stage field assessments identify likely wildlife crossing conflicts, it may be most appropriate to consider modifications to the proposed route or other project modifications to avoid or minimize conflicts.

### *Modifying Driver Behavior*

In many cases, driver safety and wildlife crossing can be enhanced by modifying driver behavior, for example, through public outreach, reduced speed limits, or warning signs.

## *Structures*

Some existing structures provide relatively safe passage for wildlife to cross over or under roads. When spaced and sized appropriately, structures such as culverts, underpasses, overpasses, and viaducts, increase permeability and reconnect habitat fragments. In some cases, it may be possible to modify existing structures to enhance their effectiveness and to make them more “wildlife-friendly.” Fencing is often incorporated into crossing structure designs to prevent animals from entering road rights-of-way and to direct them to crossing structures to allow safe passage. Vegetation and lighting are often incorporated into designs to enhance their effectiveness.

### *Project Managers, Engineers, & Planners*

Wildlife crossings can often be improved by changing driver behavior, installing fencing, modifying existing structures (e.g., culverts), or providing new crossing structures. These methods for reducing effects of existing or proposed infrastructure should be in line with the effects of these facilities on wildlife crossing. The effectiveness of these actions should be monitored as part of the project to determine whether they achieved the desired results as described in the original mitigation and monitoring plan, environmental documentation and permits. Mitigation and monitoring activities should be developed by the biologist in coordination with the PDT. Resources and funding for mitigation activities and monitoring should be incorporated into project budgets - long term maintenance and monitoring of project outcomes are essential components of transportation related crossing avoidance, minimization or compensatory mitigation measures.

## *Maintenance*

Crossing structures require regular maintenance to ensure long-term access and use by the animals they were intended to benefit. Storms may scour and vegetation may occlude culverts and underpasses, rendering them useless for wildlife passage. Maintenance staff should be involved in project planning, implementation, and post-project monitoring to ensure that designs and materials provide long-term benefits with a minimum of maintenance.

## *Post-project Assessments/Adaptive Management*

It is essential to evaluate the effectiveness of actions taken to improve public safety, reduce effects on listed species and enhance wildlife crossing to assess whether these actions were successful and to respond to situations where original actions or designs did not work as anticipated but were subsequently modified and then found to better meet project objectives. Post-project assessments must adhere to reporting requirements and meet performance standards,

should be well documented, and disseminated to feed back into subsequent project planning to help to inform future project delivery processes. Assessments should be added to the case studies on the wildlife crossings website ([http://www.dot.ca.gov/hq/env/bio/wildlife\\_crossings/](http://www.dot.ca.gov/hq/env/bio/wildlife_crossings/)) so that all Department as well as other transportation professionals may benefit from a sharing of experiences.

### *Project Managers, Engineers, & Planners*

The effectiveness of mitigation actions should be monitored as part of the project to ensure that the measures taken to avoid, minimize, or mitigate achieve established success criteria as described in the mitigation and monitoring plan, environmental documentation and permits. Mitigation and monitoring activities should be developed by the biologist in coordination with the PDT. Resources and funding for mitigation activities and monitoring should be considered and refined throughout the project delivery process. Long term monitoring, maintenance and post construction activities will require adequate funding.

# 1 What You Need to Know

## *1.1. Introduction*

The purpose of this section is to introduce practitioners to the core experiences and literature that have shaped policy on avoiding and mitigating effects of roads on wildlife species of management and legal importance. Awareness of experiences elsewhere is important to effective analysis and design, and is critical to writing environmental documents that will be persuasive to regulators, politicians, and the interested public. This section is intended to provide an overview of the literature assembled and indexed at the end of the printed manual (and in more detail in the accompanying crossings website – [http://www.dot.ca.gov/hq/env/bio/wildlife\\_crossings/](http://www.dot.ca.gov/hq/env/bio/wildlife_crossings/)).

The environmental effect analysis for any substantial highway project should consider potential effects of both the infrastructure itself and resulting changed traffic operations on wildlife and its habitats. These effects include habitat fragmentation, loss of habitat connectivity, effects on designated critical habitats, and direct or indirect effects to threatened and endangered species (Forman and Alexander 1998). Wildlife crossings, in particular, have recently received much attention due to a variety of conservation, regulatory, and public safety concerns (Transportation Research Board 2002). Many organizations, agencies, and academic scientists are addressing concerns for wildlife and habitat connectivity by studying road/wildlife interactions, including the enhancement of crossings, and avoidance or mitigation for impacts to animal movement corridors.

In general, both environmental laws (especially the California Environmental Quality Act or CEQA and the National Environmental Policy Act or NEPA and sometimes ESA or CESA) and agency policy require project planners to avoid significant effects on populations of wildlife species of management concern if possible, and otherwise to minimize the effects and to provide for appropriate mitigation of unavoidable impacts. The CEQA Deskbook (Bass, Herson and Bogdan 2001 – new edition expected soon) provides a useful step by step summary for California projects under CEQA and NEPA. For species listed under either state or federal endangered species laws, the requirements may be more stringent, and may require project components to reduce the likelihood of adversely affecting a listed species, which may include reducing fragmentation or direct mortality effects for a proposed project.

The U.S. Federal Highway Administration report, *Wildlife Habitat Connectivity Across European Highways* (FHWA, 2002), notes that despite a growing literature on highway crossing issues, there has been a gap in practical guidance for transportation agencies. The goal of this manual is to organize and integrate materials from internal agency documents and the technical literature to describe approaches for: 1) evaluating roadways for potential wildlife crossing conflicts; 2) avoiding, minimizing, or compensating (mitigating) for these conflicts; and 3) assessing the effectiveness of mitigation actions.

### **1.1.1 Why Use This Manual**

This manual surveys the wildlife crossing and related literature both to provide a useful guide to this literature as well as to provide specific, experience-based guidance on assessing and responding to wildlife crossing issues. This manual:

- reviews the federal and state statutes important to transportation professionals that are designed to protect and conserve wildlife and its habitats
- describes a process to evaluate known, predicted, or suspected wildlife crossings conflicts
- links wildlife groups to the crossing structures and actions that transportation professionals have utilized to mitigate conflicts with each group
- provides case studies of the mitigation efforts and experiences of others

This guidance manual is intended to outline current best practices and knowledge. Because the science and policy underlying wildlife crossings is advancing rapidly, the manual seeks to provide assistance in keeping informed of new developments by providing links to on-line resources, including the wildlife crossings website associated with this project ([http://www.dot.ca.gov/hq/env/bio/wildlife\\_crossings/](http://www.dot.ca.gov/hq/env/bio/wildlife_crossings/)), that are updated frequently and that will continue to provide additional, current information.

### **1.1.2 Who Should Use this Manual**

The intended primary audience for this manual is Caltrans biologists and other technical staff at the agency. It may also be useful to other transportation experts involved in planning, program management, or maintenance that need to know how roads may affect wildlife and ecological systems in California. However, readers will note that many of the details of project staging and documentation (for example: Figures 2 and 3) and some of the accompanying acronyms may be fairly specific to the steps mandated for Caltrans project delivery.

Transportation planning decisions have both a regulatory and an ecological context, and the manual seeks to integrate both to provide guidance, in the form of a process illustrated schematically in Figure 1, to those with responsibilities for identifying and mitigating wildlife crossing, listed species, habitat connectivity, and public safety conflicts.



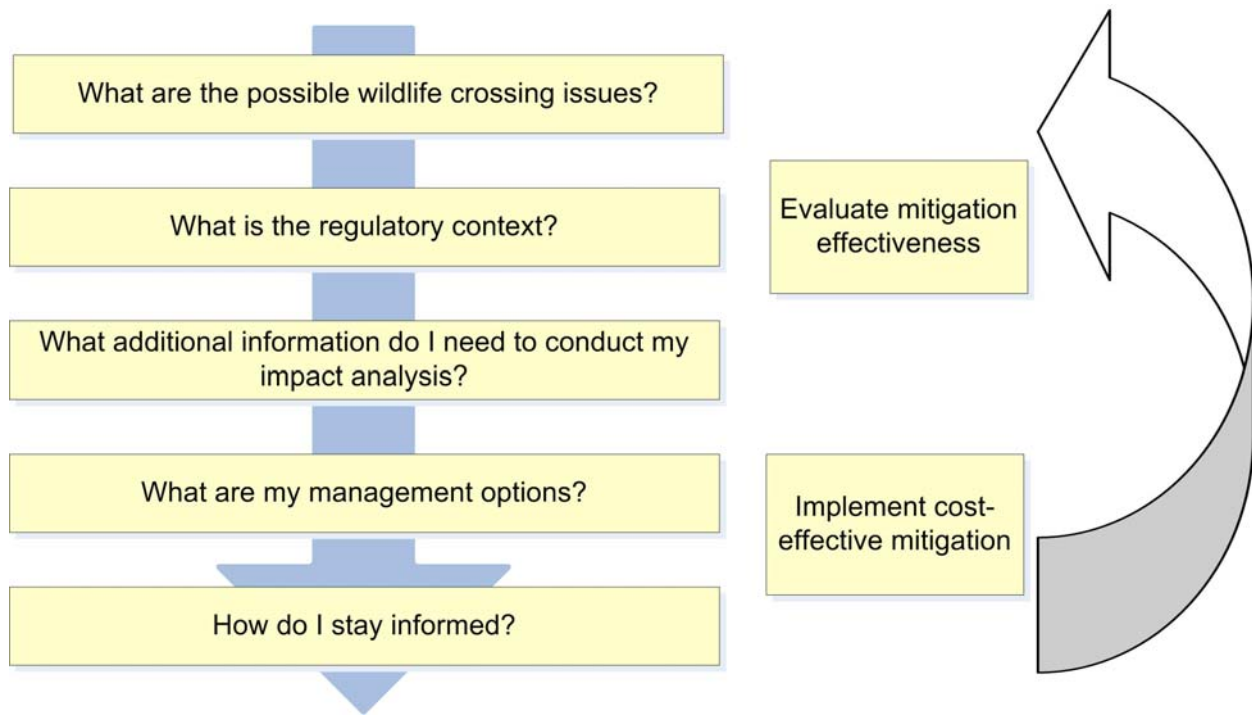

Figure 1: Assessment Flowchart

### 1.1.3 How to Use This Manual

The manual is structured to enable users to identify wildlife crossing needs throughout the planning process including the identification of sources of information on wildlife in a project area, assessment of potential effects associated with transportation facilities, consideration of avoidance, minimization, or compensatory mitigation strategies, a consideration of the relative costs associated with different strategies, and post-project monitoring and adaptive management.

The sequence of steps in this manual includes:

1. what you need to know, including how to identify wildlife crossings
2. how to assess potential effects associated with transportation facilities
3. what factors to consider in suggesting specific avoidance, minimization, and compensatory mitigation strategies, including their costs, and
4. how to monitor and assess the effectiveness of mitigation strategies, including adaptive management responses to deficiencies.

Because regulations affect many wildlife crossing considerations, the manual begins with a review of applicable major state and federal laws. The accompanying website, [http://www.dot.ca.gov/hq/env/bio/wildlife\\_crossings/](http://www.dot.ca.gov/hq/env/bio/wildlife_crossings/), provides other stepwise “views” of the manual sections. You can find “decision trees” on the website and in this manual: the Wildlife Crossings Process Decision Tree (Figure 2) and the Wildlife Crossings Project Decision Tree

(Figure 3) illustrate the Caltrans environmental review process as it relates to wildlife crossing considerations. These decision trees walk the practitioner through a series of steps to assess wildlife crossing in project planning and delivery.

Wherever possible, the manual describes experiences from California, but the wildlife crossings literature is spatially extensive, and most of this literature illustrates examples from outside California, so where California examples are unavailable, the manual describes experiences from elsewhere in the U.S., Canada, and Europe. Caltrans plans to monitor California practices as they are established and tested, and results will be assembled on the manual website and incorporated into future editions of this document.

The manual integrates wildlife considerations with existing Caltrans environmental planning processes to help the user to identify the level of assessment or evaluation that should take place in parallel with other project delivery or engineering milestones (Figures 2 and 3).

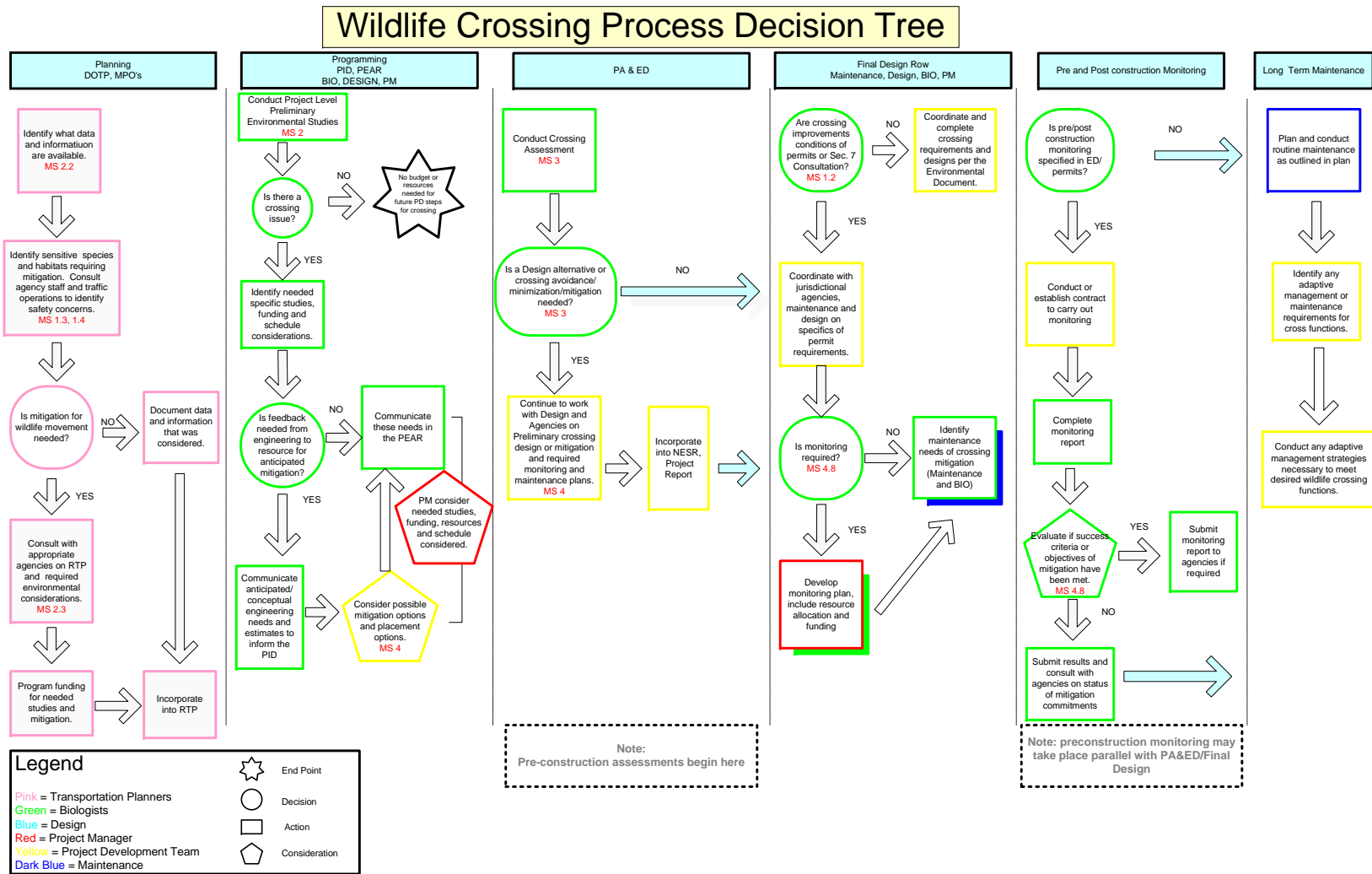

Figure 2: Caltrans Wildlife Crossing Process Decision Tree

Links to relevant sections this manual indicated in red (e.g., MS 2).

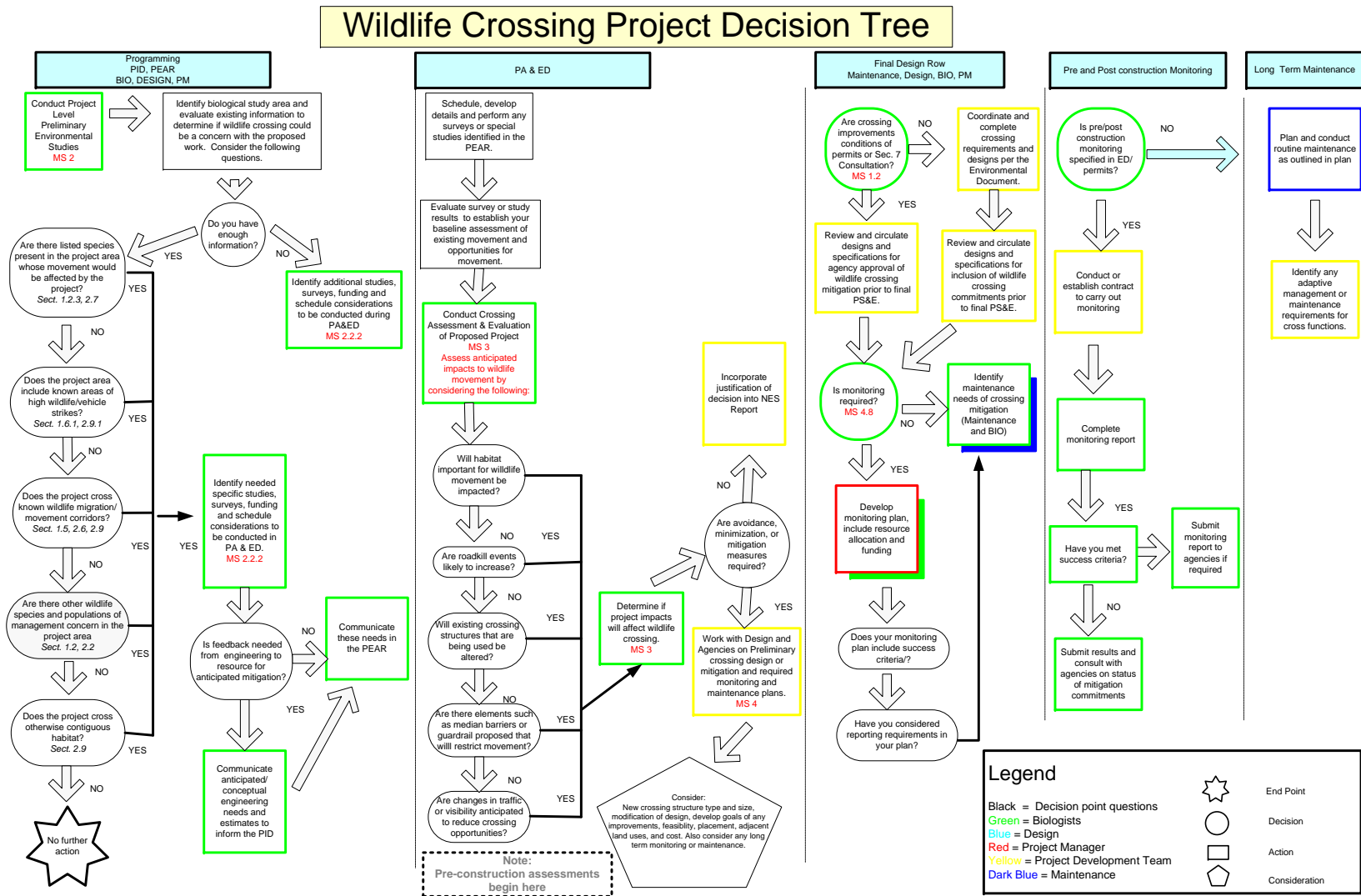

Figure 3: Caltrans Wildlife Crossing Project Decision Tree.

Links to relevant sections of this manual indicated in red (e.g., MS 3).

## ***1.2. Federal and State Wildlife Protection Laws***

Many wildlife crossing assessments, decisions, and actions are motivated by federal and state laws designed to protect wildlife and its habitats; here we review the most important wildlife-related legislation of concern to transportation professionals.

The development of a Project Study Report (PSR) requires a consideration of relevant regulations and statutes. The primary applicable laws are described in the Guidelines for developing a Preliminary Environmental Analysis Report (PEAR), the Guidance for the Preliminary Environmental Studies (PES), and in Volume III of the Environmental Handbook. This information is available in the Standard Environmental Reference (SER), Chapter 14 – Biological Resources, <http://www.dot.ca.gov/ser/vol1/sec3/natural/Ch14Bio/ch14bio.htm#ch14decisiontree>.

The California Department of Fish and Game, Habitat Conservation Branch website (<http://www.dfg.ca.gov/habcon/index.html>) has much useful information related to state regulations covering species and habitats.

Table 1, adapted from the Transportation Research Board (2002) and California Department of Fish & Game website, accessed March, 2007, presents the major federal and state wildlife laws and regulations and a brief description of how each is related to transportation. Several species of animals and some specific habitats are protected under these regulations. Transportation facilities, proposed maintenance and improvements immediately within or adjacent to sensitive habitat types or movement corridors utilized by special status species are especially affected by regulatory considerations. The frequency and magnitude of these effects depend upon the:

- life-cycle needs of the species of concern
- characteristics of the habitats utilized
- distance from the wildlife movement corridor to the transportation corridor
- level and timing of the use of the corridor in relation to highway operation, and
- characteristics of the transportation facilities themselves (Evink 1990, Transportation Research Board 2002).

A thorough review of federal wildlife legislation affecting transportation is available on the Federal Highway Administration website ([http://www.fhwa.dot.gov/environment/env\\_sum.htm](http://www.fhwa.dot.gov/environment/env_sum.htm)).

### *Federal Wildlife Laws/Regulations*

- National Environmental Policy Act
- Endangered Species Act
- Department of Transportation Act/SAFETEA-LU
- Fish & Wildlife Coordination Act

### *State Wildlife Laws/Regulations*

- California Environmental Quality Act
- California Endangered Species Act
- CDF&G, Fish and Game Code

Table 1: Applicability of major federal and state wildlife regulations to wildlife crossings.

Law	Section	Applicability
<b>Federal</b>		
National Environmental Policy Act (NEPA)		<p><i>Statute:</i> NEPA requires the consideration of environmental factors including wildlife crossing through a systemic interdisciplinary approach before committing to a course of action. The act applies to all Federally funded actions including FHWA actions. Specifically relating to wildlife crossing concerns, section 102 requires that, for every major Federal action, “a detailed statement by the responsible official on—(i) the environmental impact of the proposed action, (ii) any adverse environmental effects which cannot be avoided should the proposal be implemented, (iii) alternatives to the proposed action, (iv) the relationship between local short-term uses of man’s environment and the maintenance and enhancement of long-term productivity, and (v) any irreversible and irretrievable commitments of resources which would be involved in the proposed action should it be implemented.”</p> <p>Included with NEPA is Executive Order 11990 which requires that all Federal actions “avoid to the extent possible the long and short term adverse impacts associated with the destruction or modification of wetlands and to avoid direct or indirect support of new construction in wetlands wherever there is a practicable alternative”. Specifically section 5(b) requires consideration of “maintenance of natural systems, including conservation and long term productivity of existing flora and fauna, species and habitat diversity and stability, hydrologic utility, fish, wildlife, timber, and food and fiber resources”.</p> <p><i>Applicability:</i> A decrease in connectivity or a potential increase in wildlife vehicle collisions could be considered an adverse environmental effect. In any case where there is an adverse environmental effect, NEPA can be used as justification for mitigation of that action. NEPA specifically focuses on the context and intensity of an effect on the environment.</p> <p>The procedures for implementing NEPA are set forth in Council for Environmental Quality regulations and 23 CFR 771. Coordination with the appropriate federal, state, and local agencies is required.</p> <p>Executive Order 11990 specifically pertains to any projects nearby to wetlands and can be used as justification for wildlife crossing mitigation actions when movement associated with wetland species is impacted.</p>

Law	Section	Applicability
Endangered Species Act (ESA)	7	<p><i>Statute:</i> Section 7 of the Endangered Species Act, <b>16 U.S.C. Section 1536(a)(2)</b>, requires all federal agencies to consult with the National Marine Fisheries Service (NMFS) for marine and anadromous species, or the United States Fish and Wildlife Services (USFWS) for fresh-water fish and wildlife, if they are proposing an "action" that may affect listed species or their designated habitat. Action is defined broadly to include funding, permitting and other regulatory actions. For local governments, any project that requires a federal permit or receives federal funding is subject to Section 7. Transportation projects that may impede movement of listed species or result in their harm are covered under this section. Section 9 of the Act prohibits the take of any federally listed animal species by any person subject to the jurisdiction of the United States. Take is defined as "... to harass, harm, pursue, hunt, shoot, wound, kill, trap, capture, or collect, or attempt to engage in any such conduct." Harm has been further defined to include habitat destruction when it injures or kills a listed species by interfering with essential behavior patterns, such as breeding, feeding, foraging, or resting. "Harass" in this definition means "...an intentional or negligent act or omission that creates the significant likelihood of injury to wildlife by annoying it to such an extent as to significantly disrupt normal behavioral patterns which include, but are not limited to, breeding, feeding, or sheltering" (50 CFR §17.3). Thus, not only are Federally-listed species protected from such activities as hunting and collecting, but they are also protected from actions that damage or destroy their habitat. The term "person" is defined as "an individual, corporation, partnership, trust, association, or any other private entity; or any officer, employee, agent, department, or instrumentality of the Federal government, of any State, municipality, or political subdivision of a state, or any other entity subject to the jurisdiction of the United States."</p> <p><i>Applicability:</i> The ESA pertains to any project that may affect the feeding, breeding, or sheltering of a Federally listed threatened or endangered species. Thus, if a project will impede migration of such a species to its breeding habitat, foraging habitat, or other such activities, then this act can be used as justification for wildlife crossing mitigation actions.</p> <p><i>Other Considerations:</i> Consider if there are wetlands within or adjacent to the planning or project area. Many listed species use wetlands as breeding and feeding sites but migrate daily or seasonally to other habitat types. In a situation such as this, migratory paths and patterns should be included in the assessment of project effects and should be a consideration for any mitigation design.</p>

<p>Safe, Accountable, Flexible, Efficient Transportation Equity Act: A Legacy for Users (SAFETEA-LU)</p>	<p>6001</p>	<p><i>Statute:</i> This Act contains several sections that affect wildlife, including wildlife refuges, reductions in vehicle-wildlife collisions, including the development of a best practices manual, and modifications to existing regulations, especially to Section 101(a)(35) of title 23 USC to “(ii) reduce vehicle-caused wildlife mortality while maintaining habitat connectivity.” Section 6001 also requires early consultations with resource agencies and tribes and consideration of applicable plans (recovery plans, wildlife action plans, etc.) so that input regarding environmental effects occurs early in the planning process.</p> <p><i>Applicability:</i> This statute requires an evaluation of environmental effects at the regional scale so that mitigation costs can be considered and funds established early in the RTP process. Wildlife movement should be evaluated at the regional level in order to develop appropriate mitigation opportunities.</p>
<p>Department of Transportation Act</p>	<p>4(f)</p>	<p><i>Statute:</i> This section of the act states that “[i]t is hereby declared to be policy of the United States Government that special effort should be made to preserve the natural beauty of the countryside and public park and recreation lands, wildlife and waterfowl refuges, and historic sites.” These public lands may only be used for a transportation program or project if “(1) there is no prudent and feasible alternative to using that land; and (2) the program or project includes all possible planning to minimize harm to the park, recreation area, wildlife and waterfowl refuge, or historic site resulting from the use.”</p> <p><i>Applicability:</i> This Act only relates to the use of the above described public lands. Coordination with the DOI, Department of Agriculture (DOA), Housing and Urban Development (HUD), state, or local agencies having jurisdiction and state historic preservation officer (for historic sites) is required.</p>
<p>Fish and Wildlife Coordination Act</p>	<p>16 U.S.C. §§ 661-667e</p>	<p><i>Statute:</i> This act calls for the conservation, maintenance, and management of wildlife resources for any project that involves impoundment (surface area of 10 acres or more), diversion, channel deepening, or other modification of a stream or other body of water or the transfer of property by federal agencies to state agencies for wildlife conservation purposes. Coordination with the FWS and California Department of Fish &amp; Game is required early in project development.</p> <p><i>Applicability:</i> Any project that includes a modification to a body of water must consult with the FWS and CDFG. A project that would modify a body of water may also have wildlife movement implications associated with it. Coordination may aid in identifying improvements for wildlife movement.</p>



Federal Statute - Economic, social, and environmental effects	23 U.S.C. 109(h), (P.L. 91-605), 23 U.S.C. 128. 23 CFR 771-772	<p><i>Statute:</i> This statute was passed to ensure that possible adverse economic, social, and environmental effects of proposed highway projects and project locations are fully considered and that final decisions on highway projects are made in the best overall public interest. It is applicable to the planning and development of proposed projects on any federal-aid highway system for which the FHWA approves the plans, specifications, and cost estimates or has the responsibility for approving a program. Identification of economic, social, and environmental effects; consideration of alternative courses of action; involvement of other agencies and the public; and a systematic interdisciplinary approach are required. The report required by Section 128 may be used as the NEPA compliance document. Appropriate federal, state, and local agencies have jurisdiction.</p> <p><i>Applicability:</i> Consider this legislation during consultation and mitigation planning to support best decisions for use of funding for wildlife crossing mitigation.</p>
<b>State</b>		
California Environmental Quality Act (CEQA)	15002, 15126	<p><i>Statute:</i> According to Section 15002 of the Act, the basic purposes of CEQA are to: (1) Inform governmental decision-makers and the public about the potential significant environmental effects of proposed activities; (2) identify the ways that environmental damage can be avoided or significantly reduced; (3) prevent significant, avoidable damage to the environment by requiring changes in projects through the use of alternatives or mitigation measures when the governmental agency finds the changes to be feasible; (4) Disclose to the public the reasons why a governmental agency approved the project in the manner the agency chose if significant environmental effects, defined as a substantial adverse change in physical conditions which exist in the area affected by a proposed project are involved. When a public agency undertakes an activity defined by CEQA as a "project" then the agency must comply with CEQA. A project is an activity undertaken by a public agency or a private activity that must receive some discretionary approval (i.e. the agency has the authority to deny the requested permit or approval) from a government agency, which may cause either a direct physical change in the environment or a reasonably foreseeable indirect change in the environment. The environmental review required imposes both procedural and substantive requirements. At a minimum, an initial review of the project and its environmental effects must be conducted. Depending on the potential effects, a further, and more substantial, review may be conducted in the form of an environmental impact report (EIR).</p> <p><i>Applicability:</i> Impeding wildlife crossing and fragmenting wildlife habitat would be considered a direct change in the environment. Most proposals for physical development in California are subject to the provisions of CEQA, as are many governmental decisions that do not immediately result in physical development (such as adoption of a general or community plan). Every development project that requires a discretionary governmental approval requires an environmental review pursuant to CEQA. A project may not be approved as submitted if feasible alternatives or mitigation measures are able to substantially lessen the significant environmental effects of the project. CEQA can be used to justify wildlife crossing mitigation when a proposed project would cause a significant effect to wildlife movement. In such a case, mitigation would be required to reduce the project impact to a less than significant level.</p>

California Endangered Species Act (CESA)	2080, 2081	<p><i>Statute:</i> Section 2080 of the Fish and Game Code prohibits "take" of any species that the commission determines to be an endangered species or a threatened species. Take is defined in Section 86 of the Fish and Game Code as "hunt, pursue, catch, capture, or kill, or attempt to hunt, pursue, catch, capture, or kill." CESA allows for take incidental to otherwise lawful development projects (section 2081). CESA emphasizes early consultation to avoid potential effects to rare, endangered, and threatened species and to develop appropriate mitigation planning to offset project caused losses of listed species populations and their essential habitats. If take of a state-listed species is likely to occur, an EIR (or an equivalent CEQA document) will be prepared. Through permits or memorandums of understanding, the Department of Fish and Game also may authorize individuals, public agencies, universities, zoological gardens, and scientific or educational institutions, to import, export, take, or possess any endangered species, threatened species, or candidate species of plants and animals for scientific, educational, or management purposes. (See Fish and Game Code Section 2081(a), and Scientific Collecting Permits and Memorandums of Understanding for further explanation of the requirements for plants.)</p> <p><i>Applicability:</i> Under CESA, if a project proposes a "take" of a state threatened or endangered species, then the project would create a significant impact that would require mitigation. If the proposed "take" involves or is related to the impairment of a wildlife crossing corridor or basic wildlife movement then under CEQA mitigation would have to be established for this impairment.</p>
California Department of Fish & Game Code	1600	<p><i>Statute:</i> Section 1600 of the CDFG code requires that a Lake or Streambed Alteration Agreement be obtained prior to any activity associated with the modification of a river, stream, or lake that could adversely affect existing fish or wildlife resources.</p> <p><i>Applicability:</i> This statute can justify design modifications of elements of highway infrastructure or to a project to avoid effects to riparian areas which many species use as migration or movement corridors.</p>

Once we consider a project’s regulatory context, we can proceed to additional wildlife crossing considerations.

### ***1.3. Wildlife: Functional, Taxonomic, and Special Status Groups***

When assessing wildlife crossings, evaluations of issues and techniques for mitigating impacts depends upon the species present and expected to be impacted by transportation facilities and associated changes in traffic patterns and volumes. Planning for mitigation actions typically involves dividing all possible wildlife species in the project region into “target” or “focal” groups (Beier and Loe 1992) generally based upon a functional (e.g., animal size class) or a regulatory (e.g., special status species) classification. In practice, only terrestrial vertebrates are considered in most of the wildlife crossing literature, as fishes, equally impacted by crossing considerations and subject to their own set of environmental regulations, are treated independently, as a separate category of considerations, and studied by fisheries biologists. Thus, this manual is devoted solely to terrestrial vertebrates, including birds, although many of the crossing issues examined apply to fishes as well. More information on fish passage field

assessment protocols can be found at [http://pd.dot.ca.gov/env/bio/html/fish\\_assessmntplan\\_index.htm](http://pd.dot.ca.gov/env/bio/html/fish_assessmntplan_index.htm). Design guidelines for fish passage can be found at <http://www.dot.ca.gov/hq/oppd/fishPassage/>.

### 1.3.1 Wildlife: Functional Groups

Most transportation professional's group animals into three functional categories based upon body size, as animals of similar body size tend to have similar movement patterns, benefit from the same or similar kinds of crossing enhancements, and present similar types of public safety concerns. Animals are in most studies divided into three functional groups based upon body size: 1) large-bodied animals, including elk, deer, and bears; 2) medium-bodied animals, including coyotes, raccoons, otters, opossums, turkey, and pheasant; and 3) small-bodied animals, a diverse group including rodents, salamanders, toads, frogs, snakes, turtles, and some birds.

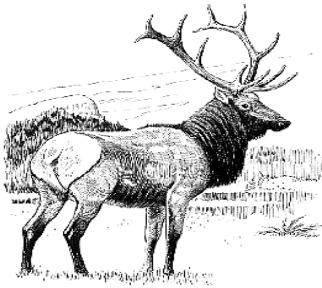

**Large-bodied animals**– include species with large home or dispersal ranges that occur most often in rural areas and require large areas for daily or seasonal movements. Require large crossing structures strategically placed along traditional movement corridors.



**Medium-bodied animals** – includes species that often live in rural areas, but may also occur in agricultural settings. Require areas of moderate size for movement and smaller, more frequently spaced crossings placed between adjacent habitat areas. Often utilize culverts

installed for fish passage and/or drainage.

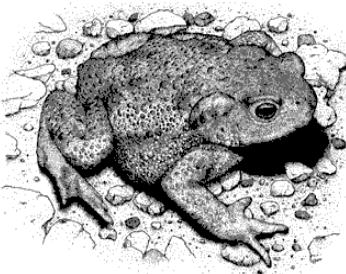

**Small-bodied animals** – includes species that live in diverse habitats and may exhibit large-scale seasonal movements between adjacent habitat areas (e.g., salamanders moving between upland and aquatic habitats). Often benefit from smallest crossing structures (e.g., culverts and pipes) with associated fencing and climb-proof walls.

### **1.3.2 Wildlife: Taxonomic Groups**

A classification system less often used for wildlife crossing research is that based upon genetic relatedness - taxonomic groups, and the four taxonomic groups recognized are the four vertebrate Classes: amphibians, reptiles, birds, and mammals. In most cases, all members of a single taxonomic group, such as amphibians, will benefit from the same type of mitigation.

Roads are known to effect bird species (e.g., Case 1978, Loos and Kerlinger 1993), and road mortality may seriously affect some special status bird species (e.g., Florida scrub jay, Dreschel et al. 1990, Mumme et al. 2000), but the effects of roads on bird populations have not been intensively studied in California nor in most other regions of the U.S. The effects of roads on bird populations have been much more extensively studied in Europe (see review of bird mortality on European roads by Erritzoe et al. 2003). Thus, this manual may seem to have a taxonomic bias; however, this apparent bias accurately reflects the history of the study of wildlife crossings in the U.S. and the relatively more extensive literature on mammalian crossings.

Similarly, this manual does not treat the crossing needs of fishes, as fish passage is studied and actions implemented by a functionally separate set of Department employees, although in some cases the crossing needs of fishes and terrestrial vertebrates may be similar, and actions intended to benefit fish passage may also benefit terrestrial species.

### **1.3.3 Wildlife: Special Status Species**

In many cases, the focal species or species group is defined by regulation (e.g., NEPA, CEQA, ESA, and CESA). When regulatory considerations are paramount, avoidance, minimization, or compensatory mitigation actions are specifically targeted to benefit the feeding, breeding, and shelter needs of special status species.

The list of special status species changes frequently and users of the manual are advised to use the most current listing, maintained by the California Department of Fish & Game and available at: <http://www.dfg.ca.gov/biogeodata/cnddb/pdfs/TEAnimals.pdf>.

For a current listing of California species protected under the U.S. Endangered Species Act, see the U.S. Fish & Wildlife Service Threatened and Endangered Species System, or TESS at: [http://ecos.fws.gov/tess\\_public/StateListing.do?state=CA&status=listed](http://ecos.fws.gov/tess_public/StateListing.do?state=CA&status=listed).

## 1.4. Special Habitats

In addition to special status species, transportation planners must consider, for regulatory as well as ecological reasons, special habitats, especially wetlands and riparian corridors. Many vertebrate species, and all amphibian species, are seasonally dependent upon wetlands, especially for breeding. Many individuals move from upland to wetland locations when rains commence and return to upland locations when rains cease; thus, if highway facilities obstruct animal movements between wetlands and uplands, mitigation measures may be necessary to facilitate movement. Research has shown that there may be a long lag period following road construction adjacent wetlands and reductions in species abundances (Findlay and Houghlahan 1997; Findlay and Bourdages 2000).

The Clean Water Act requires the delineation of wetland boundaries and special consideration of wetland-associated species. The U.S. Fish & Wildlife Service National Wetland Inventory (<http://www.fws.gov/nwi/>) seeks to map all wetlands in the U.S. and provides downloadable files of all wetland maps for analysis and publication in a GIS. NWI should be consulted for baseline data at any site with wetland habitats. NWI maps almost always list all wetlands appearing on the local USGS quad map, and often have been considerably refined beyond that from aerial imagery. However the age and quality of the data vary considerably with location, and small or seasonal wetlands, such as vernal pools, are often missed or mislabeled. Understanding where wetlands are located is essential for understanding movement needs associated with breeding, feeding, migration and shelter of many species. Review of species life cycle needs in relation to wetlands can help in understanding the need for connectivity in your area of concern.

CEQA requires that riparian corridors receive special consideration if a transportation project has potential effects on a riparian zone, and riparian corridors are especially important for wildlife because they provide habitat for many species, are often heavily used by diverse species for movement among habitat patches, and are especially important targets for conservation as riparian corridors have been severely impacted by many types of development (e.g., Warner and Hendrix 1984). At present, there is no good single source of riparian habitat maps for California,

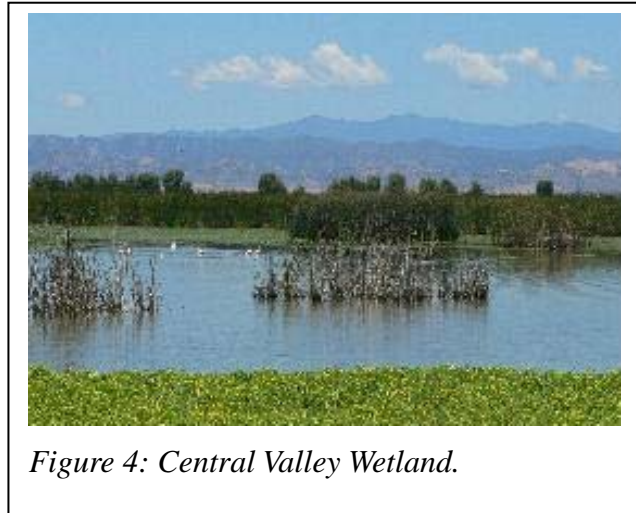

Figure 4: Central Valley Wetland.

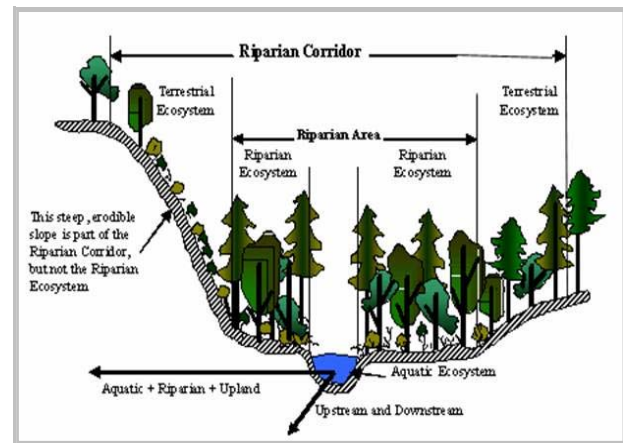

Figure 5: Riparian corridor. Derived from U.S. Forest Service website.

although a composite map is under construction by the Riparian Habitat Joint Venture (<http://www.prbo.org/calpif/htmldocs/rhjv/>) and some of the source data may be viewed through the California Department of Fish & Game's Biogeographic Information and Observation System (BIOS; <http://bios.dfg.ca.gov>). In some areas, riparian zones can be readily identified from available imagery, including the free National Agriculture Imagery Program (NAIP) 1 meter resolution imagery available everywhere in California (see <http://casil.ucdavis.edu>), and Caltrans proprietary 1-foot resolution data within 500-100 m. of state highways. However, delimiting wetlands from aerial imagery may take considerable experience with GIS and related technologies.

## ***1.5. Sources of Species-Level Information***

If you are insufficiently familiar with the species of concern in a project's scope, the following is a summary of resources that provide much useful information. Note that in addition to the resources cited here, for special status species, recovery plans and five-year review documents may be especially helpful.

### **1.5.1 Internet Resources**

- The California Department of Fish & Game web site, <http://www.dfg.ca.gov/>, is the best source of official web-based information on California's wildlife.
- The Biogeographic Information & Observation System (BIOS; <http://bios.dfg.ca.gov/>) provides an on-line map viewer for biological data generated by the Department of Fish and Game (DFG) and its partner organizations and is an excellent tool for a preliminary assessment of species of management concern that may be found within a project assessment area. Most of the datasets may also be downloaded from BIOS or other California Resource Agency websites (e.g., CaSIL – <http://gis.ca.gov>) and further analyzed using Geographic Information Systems (GIS) technologies.
- The California Natural Diversity Database (CNDDDB) is developed and maintained by the Department of Fish & Game and is included in the BIOS system. The CNDDDB contains distribution information, including GIS coverages and maps, for all state and federally listed species in California, plus other "element occurrences" representing species, rare habitats, or other biological elements (for example, bird rookeries) of management importance to Fish & Game. The CNDDDB, available at <http://www.dfg.ca.gov/biogeodata/cnddb/>, contains public as well as restricted information, but Caltrans biologists should have access to the subscription service that provides access to all of the information contained within the CNDDDB. Note that CNDDDB only records actual well-documented observations of the species involved, so that absence of a CNDDDB record at a site may not be used to infer that no species of concern are present.
- The California Wildlife Habitat Relationships system (CWHR; [http://www.dfg.ca.gov/biogeodata/cwhr/wildlife\\_habitats.asp](http://www.dfg.ca.gov/biogeodata/cwhr/wildlife_habitats.asp)) is an information resource for California's wildlife and contains life history, geographic range, habitat relationships, and management information on 692 non-marine species of amphibians, reptiles, birds, and mammals known to have breeding populations in the state. The



CWHR effort has as one component a series of printed guides, called California's Wildlife, that provide biological information for each regularly-occurring amphibian, reptile, mammal and bird in California. These species notes are available as downloadable PDF files from <http://www.dfg.ca.gov/biogeodata/cwhr/cawildlife.asp>. This web site provides updated versions of the species accounts in the three-volume set "California's Wildlife" edited by Zeiner, et al. (1988-1990) and contains 46 more accounts than the original publications, bringing the total to 692 vertebrate species. The species range maps are also available as GIS data. Note that these maps are created by experts in the biology of each species, and thus represent expert opinion about where the species might be expected to occur, rather than reporting known occurrences (as in CNDDDB). As a result, they should be viewed as predictions, but they may be better predictors than NDDB of local species in areas that have not been well-surveyed (and they cover almost all terrestrial vertebrate species, not just the rare ones). Biologists should be aware that although the CWHR system is used by most state agencies to describe relationships between California's wildlife and land cover types, the CWHR system is not a vegetation classification system *per se*, but rather an expert-based model that provides expected lists of vertebrates based upon knowledge of the land cover class present. The land cover classes in the CWHR are based upon A Guide to Wildlife Habitats of California (Mayer and Laudenslayer, 1988). The formal vegetation classification for California, used by both state and federal agencies, is that described in A Manual of California Vegetation (Sawyer and Keeler-Wolf, 1995). Be aware, however, that other vegetation and land cover classification schemes have been developed; these include the USDA Ecological Subregions of California (<http://www.fs.fed.us/r5/projects/ecoregions/>), the California Native Plant Society's Vegetation Classification, and the USDA's CalVeg Classification (<http://www.fs.fed.us/r5/rsl/projects/classification/>). Links to these are also available from the CWHR website ([http://www.dfg.ca.gov/biogeodata/cwhr/wildlife\\_habitats.asp](http://www.dfg.ca.gov/biogeodata/cwhr/wildlife_habitats.asp)).

- The U.S. Fish & Wildlife Service website (<http://www.fws.gov>) contains a wealth of useful information and is an especially good resource for information on endangered species.
- When California-specific data are scarce, it may be worth looking at national or global datasets to search for data types (for example, museum specimens) that may not have been incorporated into official CDFG or other state government compilations. An excellent compilation of on-line datasets has been assembled by the Taxonomic Data Working Group's Biodiversity Information Projects of the World (see <http://www.tdwg.org/activities/bioinformatics-projects/>)

### 1.5.2 Books

There are many excellent books on California's wildlife; here, we provide citations for only the most widely-used books on specific taxonomic groups:

- For amphibians and reptiles, the standard reference is the Stebbins field guide (Stebbins 1972).

- For birds, any of the several field guides to the U.S. or to the western U.S. would help with field identification, but for additional information, such as geographic range and preferred habitats, the books by Arnold Small (Small 1994) and Weston and Brown (1979) are more useful.
- For mammals, the standard reference is Jameson and Peeters' *Mammals of California* (2004).

Books to consider to aid in identifying effects per NEPA and CEQA include:

- Bass, R.E., A.I. Herson, and K.M. Bogdan. 2001. *The NEPA Book: A step by step guide on how to comply with the NEPA.*
- Remy, M.H., T.A. Thomas, J.G. Moose, and W.F. Manley. 2006. *Guide to CEQA.*
- Bass, R.E., A.I. Herson, and K.M. Bogdan. 1999. *The CEQA Deskbook.*

## ***1.6. Identifying Wildlife Crossings***

The first step in considering wildlife crossing issues is to confirm that a particular place or region is used as a crossing by wildlife. An extensive review of wildlife crossing and related literature shows that rather than a single, standard methodology for determining areas of wildlife crossing, there are several alternative sets of methods that can be used singly or in combination. These methodologies are used in an attempt to define the locations where assessment of highway facility effects are of greatest need to enhance and maintain wildlife movement and/or to reduce vehicle-animal conflicts and improve public safety.

In most cases, wildlife crossings have been identified by:

- repeated observations of animals crossing a small section of roadway
- a section of roadway showing an unusually high rate of vehicle-animal collisions (e.g., Clarke et al. 1998, Caro et al. 2000)
- professional assessments or judgments of qualified biologists (Clevenger et al. 2002) or highway maintenance staff (Case 1978) with experience in an area
- on-the-ground surveys of obvious wildlife corridors (e.g., documentation of game trails, tracks and other evidence indicating areas of concentrated animal movement (Scheick and Jones 1999), although animals may perceive the roadway as a barrier and refuse to cross (e.g., Riley et al. 2006)
- documenting suspected movement corridors with track plates, raked soil, remotely-triggered cameras or similar methods to confirm regions with disproportionately high use and to identify species present (e.g., Ng et al. 2004)

Additional methods which are appropriate for documenting existing crossings and for predicting locations of potential crossings include:

- modeling of actual or potential wildlife corridors based on road occurrences, wildlife habitat, wildlife occurrences, and habitat connectivity (Penrod et al. 2001, Shilling et al. 2002; Shilling and Girvetz, 2007)
- GIS models that rely upon selected landscape attributes and their interactions with highway facilities (Mladenoff et al. 1999, Clevenger et al. 2002) to predict crossing



locations

- a combination of approaches to try to enhance the detection and delineation of highway crossing areas regularly used by wildlife (e.g., Ng et al. 2004)

When crossing issues are documented or expected, it is essential to:

- design a field assessment of the type and nature of crossing issues involved
- identify the species of animals present
- document how the focal species are or may be impacted by a highway facility or proposed facility or facility improvement
- develop a relative assessment of the frequency and timing of the conflict(s)

Each of the federal and state regulations summarized in Table 1 has its own statutory requirements given an expectation of significant effects:

- ➔ CEQA requires findings of significance and documentation of cumulative effects
- ➔ NEPA requires a consideration of environmental context and intensity, with specific consideration of ecologically critical areas and public controversy
- ➔ when listed species may be affected, ESA requires consultations with the U.S. Fish & Wildlife Service to consider a project's potential for jeopardy as well as its effects on critical habitat
- ➔ CESA also requires a consideration of jeopardy and efforts to minimize and fully mitigate for impacts

### 1.6.1 Case Studies: Existing Efforts to Enhance Wildlife Crossing

Caltrans practitioners may learn much from the experiences of others; here are provided some case studies of existing projects in California. Please consult the wildlife crossing web site ([http://www.dot.ca.gov/hq/env/bio/wildlife\\_crossings/](http://www.dot.ca.gov/hq/env/bio/wildlife_crossings/)) for additional case studies and/or to add another case study record.

#### *Existing Efforts in California*

- U.S. 395 Wildlife Undercrossings. Three undercrossings were installed in 1976-1978 under U.S. 395 in northeastern California primarily in response to elevated rates of vehicle-deer collisions during deer spring and fall deer migrations (Figure 21). This project was well documented by Ford (1976).
- Desert bighorn sheep: several on-going Caltrans studies focus on desert bighorn sheep (*Ovis canadensis*)

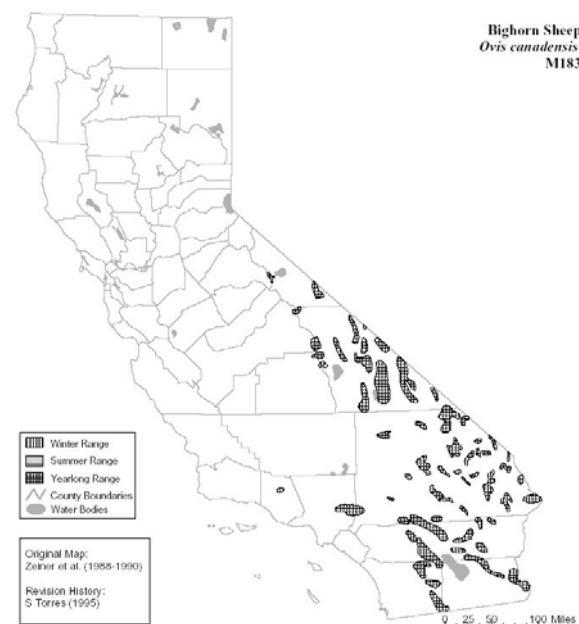

1 Figure 6: Range of California Bighorn Sheep

Website: [http://dap3.dot.ca.gov/nq/env/bio/wildlife\\_crossings/](http://dap3.dot.ca.gov/nq/env/bio/wildlife_crossings/)

*nelsoni*). Desert bighorns naturally range over approximately 20% of California, in the southeast portion of the state. The range of the desert bighorn includes several isolated mountain populations separated by desert, with movement among habitat patches necessary to ensure population persistence and genetic interchange (Epps et al. 2005).

- Ventura County: Ventura County’s “Designing Road Crossings for Safe Wildlife Passage” is a project of the Ventura County Planning Department and the Donald Bren School of Environmental Science & Management at the University of California, Santa Barbara. The final report of this project provides a comprehensive overview of wildlife crossing issues and mitigation strategies and is available at: [http://www.bren.ucsb.edu/research/documents/corridors\\_final.pdf](http://www.bren.ucsb.edu/research/documents/corridors_final.pdf). This project continues as the county works to adopt these measures as part of its CEQA initial study assessment guidelines. In addition, Caltrans has funded an intensive wildlife corridor assessment of SR 118 (report available as a PDF available at: [http://www.dot.ca.gov/dist07/resources/envdocs/docs/H118css\\_WCA.pdf](http://www.dot.ca.gov/dist07/resources/envdocs/docs/H118css_WCA.pdf)). This work continues as the SR 118 Working Group to address regional wildlife crossing issues along this state highway.

### *Examples of Wildlife Crossing Projects Outside California*

The following websites provide examples of wildlife crossing projects outside of California:

- Wildlife crossing projects in several states are described in Transportation: Protecting Species, Enhancing Ecosystems, available at: <http://www.contextsensitivesolutions.org/content/reading/taking-the/resources/taking-the-high-road/>.
- The National Cooperative Highway Research Program published a report in 2002, NCHRP Synthesis 305: Interaction between Roadways and Wildlife Ecology, available at: [http://onlinepubs.trb.org/onlinepubs/nchrp/nchrp\\_syn\\_305.pdf](http://onlinepubs.trb.org/onlinepubs/nchrp/nchrp_syn_305.pdf).
- Summaries of several projects from Washington State, Maine, Montana, and Slovenia are provided in Carr et al. (2003) Appendix I, page 77 (available at: [http://www.metro-region.org/library\\_docs/trans/wc\\_final.pdf](http://www.metro-region.org/library_docs/trans/wc_final.pdf)).
- The recently-completed (2006) Arizona DOT effort to locate potential linkage zones is an excellent example of a statewide effort to identify, map, and prioritize wildlife corridors ([http://www.azdot.gov/Highways/OES/AZ\\_WildLife\\_Linkages/assessment.asp](http://www.azdot.gov/Highways/OES/AZ_WildLife_Linkages/assessment.asp)). The Arizona effort uses multiple criteria to prioritize mitigation needs and considers the potential effects of all kinds of development on corridors and does not seek to identify specific areas where highway crossing mitigation actions are required. The Arizona study also seeks to integrate an index of threat, with those corridors with highest biological value and greatest threat (e.g., due to proposed development) receiving the highest priority.

## 2 Baseline Assessment

Your baseline assessment will document the current conditions on wildlife passage and critical habitats and take into account the 1) project type, 2) regulations that pertain to species and habitats in the project area (Table 1), and 3) presence of species status species and habitats. Table 2, below, lists some project types and some potential wildlife crossing effects associated with each. You will utilize the sources of information described in Section 1 to review what is known about wildlife in the project area and evaluate and summarize this information to place this project into a regional context and characterize existing conditions.

Table 1: Project types and potential crossing effects.

Project Type	Potential Crossing Effects
New highway	Bisection of existing habitat, interrupted migration/movement patterns, genetic isolation of populations, introduction of possibility for collision
Highway widening	Increased distance to cross, potentially greater traffic volumes
Installation of median barrier	Reduced permeability, greater risk of animal-vehicle collisions, interrupted migration/movement
New off- or on-ramps	Potentially greater traffic volumes in rural areas, added overall facility footprint
Bridge retrofit	May result in reduced or increased opportunities for crossing
Routine maintenance	Clearing vegetation, and other material may affect the attractiveness and use of a particular structure (e.g., road-side, culvert)

### 2.1. Basic Steps to Establish Your Baseline

To fully understand wildlife crossing at the project level, it is important to have a landscape level understanding of wildlife movement in your region. At the project level, establishing your baseline for wildlife movement is essential to aid in your project effect analysis.

When assessing wildlife crossings, Caltrans biologists may follow a process that consists of the following steps:

1. Establish a basic understanding of wildlife movement needs and corridors in your region. As appropriate, provide information and expertise to Regional Transportation Planners. Also this basic understanding can help you in project level analysis.



Figure 7: Bear Crossing

2. Understand regional and project level connectivity and crossing functionality.
3. Establish your baseline for your proposed project region and direct project area:
  - Identify, acquire, and review existing data
  - Evaluate existing information to develop an understanding of wildlife movement in your project area
  - Evaluate the need for field surveys
4. Identify the need for and the goals of additional field surveys:
  - Establish goals of additional field surveys
  - Select sites for field surveys
  - Evaluate and select appropriate survey methods
  - Consider sample sizes, survey intensity, and other elements of data collection
  - Conduct field surveys
  - Evaluate data set
  - Use collaborative approach – involve agencies, NGOs

### **2.1.1 Understanding Landscape-level Connectivity: Bioregional Perspective**

To begin your assessment of a project's potential effects on target species, the project must be placed in a bioregional perspective; a regional perspective is required because:

1. local impacts may affect wildlife species, especially those with large home ranges, on larger spatial scales
2. it is necessary to help to define all of the species and potential wildlife/highway conflicts that may exist, and
3. regulatory considerations (CEQA and NEPA) require the assessment of cumulative effects, including local effects on regional issues such as habitat connectivity, linkages, and wildlife corridors.

It may be useful in bioregional assessments to utilize the 10 bioregions recognized by the California Interagency Natural Areas Coordinating Committee (INACC; <http://ceres.ca.gov/biodiv/Bioregions/INACC.pdf>) as depicted in Figure 8.

Each of California's bioregions, described more fully on the CERES system ([http://ceres.ca.gov/geo\\_area/bioregions/mapindex.html](http://ceres.ca.gov/geo_area/bioregions/mapindex.html)), contains a unique combination of plants and animals and thus a unique set of potential wildlife crossing issues.

Coordination with the Natural Community Conservation Planning group in the California Department of Fish & Game (<http://www.dfg.ca.gov/nccp/index.html>) may be useful, especially at the bioregional scale, as this group works with numerous private and public partners to take a broad-based ecosystem approach to planning for the conservation of California's biodiversity

and may enhance communication and knowledge transfer among Caltrans staff and its collaborators.

Environmental planning documents under NEPA and CEQA are required to address not only effects within the project site, but also the environmental setting of the project and its cumulative effects on a landscape basis (in other words, its interaction with other environmental effects in the surrounding areas). Environmental documents are being found deficient in increasing numbers when cumulative effects are not adequately addressed. Consequently, if projects potentially disrupt habitat connectivity, especially for wide-ranging species (deer, elk, mountain lion), it is wise to discuss potential regional effects in the environmental documents.

When evaluating regional wildlife movements, review all available information, including the results of GIS analyses and models that may have been produced by other state or federal agencies, county planners, or NGOs. There have been several large-scale GIS-based assessments of wildlife corridors and/or movements in California, and these should be examined early in the project planning process. To date, the only statewide effort to identify and map wildlife corridors was the Missing Linkages Project following the statewide Missing Linkages workshop held at San Diego Zoo, November, 2000 (<http://www.calwild.org/resources/pubs/linkages/index.htm>).

Examples of bioregional assessments from Southern California include:

- The Puente-Chino Hills Wildlife Corridor. Although not explicitly devoted to wildlife crossings, this project examines many of the issues related to connecting wildlife habitats (primarily mountain lion habitats); see <http://www.habitatauthority.org/pdf/pg1-12v2b.pdf>
- The Coal Canyon Wildlife Corridor. This corridor is critical to the survival of the mountain lion in the Santa Ana Mountains; this project is described at [http://www2.for.nau.edu/research/pb1/Service/coal\\_canyon\\_address.htm](http://www2.for.nau.edu/research/pb1/Service/coal_canyon_address.htm)
- The South Coast Missing Linkages Project. An on-going effort involving many agency and NGO collaborators that identified many potential wildlife corridors throughout coastal Southern California (<http://www.scwildlands.org/>).
- The Conception Coast Project Regional Conservation Guide. This guide provides information, including movement corridors and habitat linkages, on the mountain lion and sensitive species in the Conception Coast region ([http://www.conceptioncoast.org/Conception\\_Coast\\_Project.html](http://www.conceptioncoast.org/Conception_Coast_Project.html))
- Desert Bighorn Sheep. Several investigators have used radio-collars to study fragmentation issues of desert bighorn sheep in the Peninsular Ranges of California (e.g., Rubin et al. 1998, Butierrez-Espeleta et al.

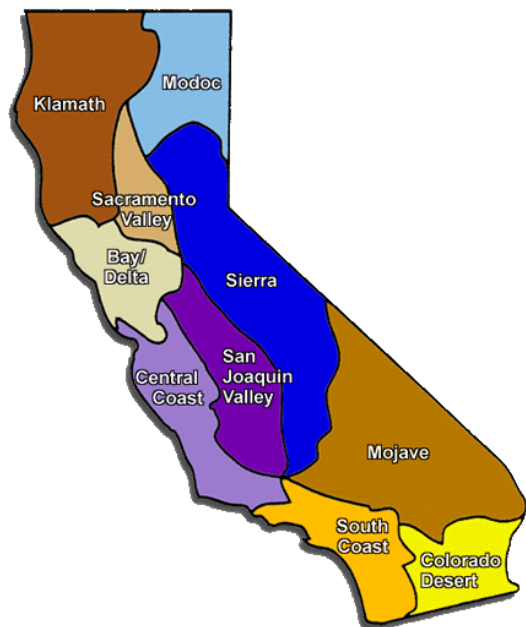

2000)

- The South Coast Wildlands Project. A continuing study in Southern California to identify potential wildlife corridors with a system of ranking by relative threat (<http://www.scwildlands.org>)

Examples of Central and Northern California assessments include:

- A Guide to Wildlands Conservation in the Central Coast Region of California. This study showed places where wildlife corridors were likely to be present and were threatened by highways and other development (Thorne, Cameron, and Jigour 2002; <http://cain.nbii.org/repository/CC.pdf>).
- A Guide to Wildlands Conservation in the Greater Sierra Nevada Bioregion. A combination of habitat models, focal species, and threats to habitat quality was used to indicate core and connectivity areas/corridors (Shilling and Girvetz 2007; Shilling et al. 2002; <http://cain.nbii.org/repository/Sierra.pdf>).
- California Tiger Salamanders. Pyke (2005) looked at the endangered California tiger salamander as a case study for the importance of habitat linkages for population persistence and Barry and Shaffer (1994) looked at the Stanford University population of the species and recommended mitigation measures, since implemented.

Caltrans-sponsored projects in progress are applying similar methods to assess potential wildlife corridors for individual species at the project-to-county scale. These and similar efforts will help practitioners to identify regions with high corridor potential and may be useful on an individual project scale to suggest areas for further investigation. Areas identified as priority wildlife corridors should be assessed to:

1. inventory existing crossing infrastructure to assess whether it is sufficient and effective at connecting wildlife habitats and facilitating crossing
2. identify and prioritize particular crossing points for additional crossing enhancements and mitigation efforts, and
3. identify adjacent land uses to ensure any investments in highway infrastructure match the anticipated land use.

These efforts, and the other studies listed above, suggest useful methodologies that take advantage of existing expertise and which may be adopted by Caltrans as a component of efforts to set wildlife crossing priorities.

### **2.1.2 Understanding Project-level Crossing Issues**

In considering a project's potential effects at the local level, the practitioner seeks to determine what kind of avoidance, minimization or compensatory-mitigation strategy will work best given the project type, habitat, and focal species.

In accordance with the project type and its potential effects, the practitioner must first define the target or focal species by identifying regulatory, management, public safety, and/or public outcry considerations for the species known or suspected to occur in the project area.

## 2.2. Developing Your Baseline for Wildlife Movement

It is important to assess projects for potential wildlife crossing conflicts prior to the construction of infrastructural barriers (Hardy et al. 2003, Van Der Grift and Pouwels 2006; Scheick and Jones 1999). The documentation of pre-construction conditions will provide a project base-line assessment that is unbiased by any construction activity.

Baseline assessments should be conducted for any special status species that may potentially occur within a project's scope as well as species that may present public safety concerns (e.g., deer, elk). Establishing a baseline includes reviewing and documenting existing sources of information that provide insight to wildlife movement as well as possibly generating some field survey data to better define wildlife crossing in your particular project location.

### 2.2.1 Identify, Acquire, and Review Data Sources

The first step in an assessment of a project's potential effects on target species is a review of all existing data sources. Efforts to identify existing information should include:

- consultations with Caltrans biologists, GIS, and maintenance staff
- consultations with other land-management agency biologists and GIS staff, especially to determine whether special status species or critical habitats may be impacted by a project
- consultations with other experts including county planners, NGO, resource conservation district, and local conservation agency field staff
- consultations with sheriff's departments and State Highway Patrol offices as potential sources of road-kill data
- a thorough literature review (Caltrans library, academic libraries, web-based sources such as Google Scholar), including species recovery plans and updates
- a review of California Department of Fish & Game resources (e.g., BIOS, CNDDDB, CWHR)
- a review of the results of predictive modeling in the region, if any
- consultations with biological consultants
- review of old reports from the area (BA, NES, etc.)
- conversations with local landowners, farmers, cooperative extension specialists, fishermen, hunters, etc.

#### *Known Crossing Conflict:*

- Road kills
- Documented roadway barrier effects

#### *Suspected Crossing Conflict:*

- Reported wildlife crossing
- Appropriate habitat/landscape
- Documented signs of occurrence

#### *Predicted Crossing Conflict:*

- Results of GIS analysis
- Professional judgment
- California Wildlife Habitat Relations



- Department of Defense staff, if applicable
- University researchers
- CalFish database

A review of all of these data sources will help to most thoroughly document what is already known about wildlife species and their movements in the project area. This initial review of data sources should be conducted during the PEAR development, and based on this review you should determine whether additional, targeted field surveys and assessments are needed as well as identify any preliminary anticipated needs for wildlife crossing improvements.

### **2.2.2 Identify the Need for Additional Field Surveys and Assessments**

Potential project effects on wildlife crossing should initially be assessed when a highway project is in its early planning stages. When wildlife crossing conflicts have been reported or are suspected or predicted, it may be necessary to conduct field surveys to confirm the presence of, identify, and estimate the abundance of focal species in the project area. It will also be necessary to conduct field surveys in those cases when your review of existing information determines that no wildlife information exists from the project area. Keep in mind that field surveys or assessments must aid in a determination of whether the effects of a project are significant, as a finding of significance is usually what results in the recommendation to incorporate wildlife crossings to reduce effects. A finding of significance may result from an analysis of a project's effects under CEQA and NEPA, and having sufficient data to determine effects relative to populations. Simply documenting whether animals are prevented from crossing or are getting hit while attempting to cross is not usually sufficient to conclude that a project's effects may be significant – there must be evidence of a project's effects on the species population, available habitat connectivity, ability to fulfill life cycle needs, migration, etc.

#### *Establish Intended Outcome or Application of Survey Data*

Once you have established that additional information is needed, it is important to identify what information is needed, why it is needed, and how you will obtain this additional information. In order to choose the right survey strategy, understand what question you are trying to answer. The procedures for analyzing survey data depend upon the detection methods used and the goals of the study. This section reviews the kinds of information one can obtain through field surveys: determining presence/absence, estimating relative or absolute abundance, or identifying use of existing structures or crossing of the existing roadway.

*Presence/Absence.* The minimum amount of information to be obtained through a field survey is whether focal species do or do not occur in the study area. Presence or absence can be determined with all of the methods described in Table 3, below. Be aware, however, that no method of detection works 100% of the time, and that while the detection of an animal confirms its presence, the lack of detection does not confirm its absence (“absence of evidence isn’t evidence of absence”). For example, Hilty and Merenlender (2000) found on their study site in Sonoma County that baited track plates failed to detect mammal species detected by remotely-triggered cameras. The limit of interpretation of such survey data is not that particular species do or do not occur in the study area, but rather that they were or were not detected given the



methods used. Use your knowledge of the focal species habits to conduct your surveys at the time of the year when the species is present and most active (e.g., during migration for ungulates and during breeding movements for amphibians).

*Relative abundance.* A greater amount of information is obtained, and may be required by regulation, when one estimates the relative frequency of occurrence of focal species in a study area. Relative abundance can be estimated from frequency of movement past defined points, for example by periodic counts of tracks (track plates and raked soil) and remotely-triggered camera data (Mace et al. 1996; Drennan et al., 1998; Clevenger and Waltho, 2004). Here, one would report the numbers (and identities) of animals recorded per unit of time. An advantage of obtaining relative abundance data is that one may then compare the estimate of relative abundance of animal species at one site to those of other sites and get a quantitative estimate of among-site differences in relative abundance. Estimates of relative abundance are usually expressed as numbers of observations per unit of time or effort (e.g., number of observations per hour or per number of track plate stations per unit of time) rather than as numbers of animals per unit of area, because these methods do not generate estimates of numbers of animals per unit of area (absolute estimates of abundance). Keep in mind that the abundance of the focal species may change seasonally.

*Absolute abundance.* The greatest amount of information on a focal species in a study area is obtained through an estimate of its absolute abundance (animals per unit area), and such estimates may be required to estimate crossing effects on populations. However, the estimates of absolute abundance require the most intensive field investigations, and may be logistically challenging. When one calculates an estimate of absolute abundance, an estimate of the relative importance of the local population to the regional or global population is possible, as may be required under NEPA and CEQA. In the case of special status species, the most important considerations involve estimates of absolute abundance and comparison of the local abundance to the species as a whole (Craighead et al. 2001, Dodd et al. 2004). For conspicuous animals, direct observations may yield absolute estimates of abundance (e.g., pronghorn in low shrub habitats, salamanders moving to breeding ponds), but for less conspicuous animals, remotely-triggered cameras may provide the best method to estimate absolute abundance, as it is necessary to discriminate among individuals to estimate absolute abundance, and remotely-triggered cameras may provide the most reliable method to identify individuals of a species (Mace et al. 1994). For most vertebrates, mark-recapture methods or tracking of individuals are typically required for population estimates that can withstand technical or legal challenges.

*Mortality Index.* Obtaining an absolute estimate of mortality (expressed as the proportion of the population that dies per year) is difficult for mobile species and often involves intensive field work over an extended period of time. However, for species with a regional population that is restricted to a small area, it may be possible to estimate the rate of annual mortality due to roadkill because the size of the regional population can be estimated. For example, Gibbs and Shriver (2002) found that roadkill may cause regional declines in land and large-bodied pond turtle populations in the eastern and central United States. The same authors (2005) found that rates of mortality of pool-breeding amphibians were strongly positively correlated with traffic volume at their study site in New York. Twitty (1941) and Barry and Shaffer (1994) found that road traffic was a major source of mortality of California tiger salamanders during their seasonal migrations from their upland aestivation sites to their lowland breeding pond on the campus of

Stanford University. Thus, for species with restricted ranges and population sizes (amphibians, some reptiles, small-bodied mammals), and which, coincidentally, are often special status species, it may be possible to estimate absolute rates of mortality.

However, for mobile species such as medium and large-sized mammals and birds, it is more difficult to estimate the size of the population of interest as well as the rate of mortality due roadkill (Romin and Bissoette 1996, Groot Bruinderink and Hazebroek 1996), and thus rates of roadkill are more typically expressed as a mortality index, and the index consists of an estimate of the number of individuals killed per length of road surface per unit of time. Multiple indices derived from several locations can be compared, thus providing a means to evaluate the relative rates of mortality due roadkill, although the underlying factors responsible for differences may not be known (differences in animal abundances, etc.). In many cases, these rates are often expressed in relation to daily or seasonal periods of time, as mortality rates are often highly correlated with traffic volume, and traffic volume, as well as animal movements, fluctuate daily as well as seasonally (Ford 1976, Case 1978, Sullivan et al. 1984).

*Habitat Fragmentation.* If the goal of your field survey is to document habitat fragmentation, you may need more intensive methods to obtain additional information. Habitat fragmentation may result from extreme levels of mortality caused by vehicle-animal collisions (e.g., Lodé 2000, Dodd et al. 2004) and it may be essential to document high levels of road kill through frequent field surveys to demonstrate that the roadway presents a barrier. In other cases, animals may perceive the roadway as a barrier and will not or only rarely attempt to cross. Riley et al. (2006) studied dispersal patterns of bobcats and coyotes across the Ventura Freeway in southern California and utilized radio-tracking and genetic “fingerprinting” to identify individuals. Their study, conducted over 7 years, demonstrated a very low level of crossing and consequent effects on population isolation, including genetic effects. Similar effects on the movements of desert bighorn sheep were demonstrated by Epps et al. (2005) who used radio-collars to show that roads imposed territory and range constraints on animals that were moving among mountain ranges in southeastern California. Similar intensive field methods may be necessary if you suspect road effects on animal migratory movements through your study area (e.g., Ford 1976). Separation of breeding, feeding, and sheltering habitat may also be a concern that you may want to consider as part of your field assessment.

Once you have determined the intended goal(s) of collecting additional information from the field, a wildlife biologist must spend time in the field to document wildlife presence, abundance, and spatial and temporal patterns of movement. Wildlife biologists have employed a variety of techniques to assess wildlife presence and abundance. Scheick and Jones (1999) provide details of their pre-project survey of large and medium-bodied mammals in North Carolina, and their methods are widely applicable to road crossing-related wildlife surveys. These include track-count surveys, ditch crossing surveys, monitoring of trails using remotely-triggered infra-red cameras, and GIS modeling to predict likely movement corridors at landscape scales. Additional methods commonly employed to detect and document animal movements include track plates and raked soil. In some cases, a combination of techniques such as gypsum on raked soil, may provide enhanced detection (Ng et al., 2004). For surveys designed to document movements of mammals, Sanderson (1966) provides a comprehensive overview of both theory and practical application.

There are five main steps to conduct field assessments of wildlife presence and movements:

1. Select survey site(s)
2. Select detection method(s)
3. Collect data
4. Analyze and interpret data
5. Report results

### *Survey Site Selection*

Field surveys should document signs (game trails, etc.) of concentrated animal movement to best define and characterize wildlife crossing issues (e.g., Scheick and Jones 1999). While in the field, one should consider not only the regions defined by road kills and other direct evidence of crossing conflicts, but should also consider the landscape attributes that tend to favor animal movement, including riparian corridors, ravines or ridgelines, habitat edges, and patches of relatively undisturbed habitat, and seek to document barrier effects, i.e. regions where movement corridors are interrupted by highway infrastructure and where habitat connectivity is lost because animals refuse to cross (e.g., Riley et al. 2006).

Many large and medium-sized mammals follow traditional routes across regions of uneven terrain in order to move most efficiently across the landscape. These movements often result in concentrated animal movements across features such as ditches, and these routes may be surveyed to estimate the numbers and species of animals present and may suggest appropriate locations in which to site additional detection devices (e.g., track plates, raked soil, and remotely-triggered cameras). Ditch crossing surveys will not yield an index of abundance unless the substrate within the ditch crossing is refreshed at frequent intervals.

Beier and Loe's (1992) schema, while not specifically written with highway facilities in mind, provides an excellent functional description of wildlife corridors as well as a checklist for evaluating corridors. According to Beier and Loe, the steps to evaluate a wildlife corridor are to:

- identify the habitat areas the corridor is designed to connect
- select several species of interest from the species present in these areas
- evaluate the relevant needs of each selected species
- for each potential corridor, evaluate how the area will accommodate movement by each species of interest
- draw the corridor(s) on a map
- design a monitoring program to confirm animal use

Although not all wildlife movement occurs within corridors, by utilizing such a schema, a biologist may confirm the locations of corridors required to permit movements of species of interest.

The choice of where to survey for wildlife occurrences depends upon the project scope and the information needed to best characterize the habits and habitats of the focal species or species group. Following expert consultations, literature review, and examination of existing data; seek evidence of occurrence in habitats utilized by the focal species along or across the roadway itself as well as in appropriate habitats more distant from the right-of-way: recall the need for a local as well as a bioregional perspective. Regions where animal signs have been documented may then become the foci for more intensive investigation using the methods described below.

Within a survey area, be sure to survey sites with:

- available natural plant cover
- reported animal-vehicle collisions
- previously reported occurrences of focal species
- constrained opportunities for crossing such as a stream crossing in an agricultural area
- existing structures (e.g., culverts) that may be used by wildlife

### *Survey Sample Size*

While selecting a sample size is a complex issue which requires the consideration of many variables, the following is a brief discussion of the most common considerations. For more formal treatments of sample size considerations, please see Sutherland 2006 and Appendix II, Sample Size Equations, in Elzinga et al. 2001, or the U.S.G.S. Patuxent Wildlife Research Center's Managers' Monitoring Manual treatment of sample size calculations at: <http://www.pwrc.usgs.gov/monmanual/cvs/>. As a general rule, the more data you are able to obtain, the better, as chance events play disproportionately larger roles in small samples, and if you were to extrapolate patterns from small sample sizes you increase the risk of erroneously characterizing the wildlife in a study site. Where special status species are involved, it may be useful to refer to peer-reviewed scientific or technical studies as well as published recovery plans to determine: 1) how many sampling events (dates and locations) are needed, 2) what were the most effective methods to document effects to populations, and 3) what statistical tests were employed to determine adequate sample sizes and analyze data.

For rare species, it may be a challenge to obtain sufficient sample sizes to be able to detect effects of regulatory importance (e.g., declines of 5% or lowering net reproductive rates below the replacement rate). In such cases, a formal power analysis (e.g., Cochran 1977, Toft and Shea 1983, Hatch 2003, Peery 2004, Zielinski and Stauffer 1996) can guide biologists and regulators in assessing what sample sizes and effect guidelines are practical.

You may wish to consider collaborating with a nearby academic institution as academic scientists and graduate students with experience in statistics and GIS may help to address study design, data analysis and interpretation, and related questions.

Clevenger and Waltho (2004) provide an excellent example of data analysis and interpretation:

- examined the use of crossing structures in Banff National Park, Alberta, Canada
- predicted the use of structures by 13 independent variables

- compared their observations to their predictions
- concluded that attributes of the crossing structures are most important in determining use, and that landscape variables (distance to cover) was of significance only to carnivores (mountain lions – negative correlation) and ungulates and grizzly bears (positive correlation)

Their study is recommended for its emphasis on good study design as well as for its clear and sophisticated data analysis and interpretation of results.

### **2.2.3 Survey and Detection Methods**

Choosing an appropriate detection method is as important as choosing the right place to conduct the survey. Table 3 lists the most commonly used field assessment methods, the most appropriate target group(s) of animals for each method, and the conditions under which each method is most useful. Note that these methods may be used in concert with one another to help provide more conclusive information on how or where wildlife is moving within a given area. In addition to assessing presence or absence of wildlife, these methods may also be used to derive an index of abundance, which may be necessary in cases where relative frequency of use is more important than presence/absence, as in efforts to derive population-level estimates of a project's potential effects. To derive an index of abundance, devices such as track plates must be maintained and checked for tracks or other sign through time. The index of abundance, then, would be reported as the number of tracks observed per unit of time.

It is desirable to utilize enhanced detection methods such as track plates or raked soil for medium and small-bodied animals, as in many cases other evidence of use (e.g., tracks in native soil, scat) will otherwise be easily missed. To enhance the probability of detection, it is important to establish several survey sites, and if possible and appropriate, you may want to consider using remotely-triggered cameras, as these have been found to more thoroughly and reliably document the occurrences of carnivorous mammals on a study site in Sonoma County (Hilty and Merenlender 2000). Similar comparisons in other locations, with other animals would be extremely useful to inform Caltrans biologists of the best, most reliable methods to use.

Table 2: Field assessment methods and most appropriate animal group(s) for each.

<b>Method</b>	<b>Target Group</b>	<b>When and Where Useful</b>	<b>Intended Results</b>	<b>Comments</b>
Visual (=Field) Observation, including spotlighting at night	All sizes and taxa; spotlighting more effective for medium and large nocturnal animals	All locations and circumstances; spotlighting most effective with nocturnal animals.	Presence, behavior, species identification, highway interface, habitat fragmentation	Most widely used method and is often the least expensive. At night, high-intensity hand-held spotlight often used for nocturnal animals. Enables survey of large area relatively quickly.
Track count surveys	Large & medium mammals	For areas where crossing is likely and substrates are available (e.g., mud, snow).	Presence, species identification, relative abundance	May be appropriate for smaller vertebrates if substrate is able to record tracks; inexpensive.
Track plates	Medium & small-bodied vertebrates	Most useful when crossing occurs in a constrained area (e.g., semi-vegetated under-crossing). Requires inexpensive equipment and can be replicated at several locations across a study site.	Presence, possibly species identification, relative abundance	Wood or metal surfaces upon which gypsum, ash, or other materials are placed to enhance detection of tracks. May use boxes, and be baited or unbaited.

Cover Boards	Amphibians and some reptiles	Most useful for hard-to-detect species that often seek shelter under logs or in the soil.	Presence, species identification, relative abundance	Wooden boards of various sizes that are often painted white on top and deployed at several locations to serve as cover for amphibians and some reptiles. May not be suitable in windy environments.
Raked soil	All terrestrial vertebrates	Same as for track plates with presence of appropriate soil substrate. Also used along highway rights-of-way where crossing is more dispersed.	Presence, species identification, relative abundance	Preparation of soil or provided substrate to enhance detection and/or to record number of tracks per unit of time.
Live trap	Primarily for mammals, all size classes	Useful to capture animals for marking or tagging and subsequent release	Capture individuals for tagging and/or marking to distinguish individuals in the field	Intensive, relatively time-consuming method used primarily for mammals. Traps for small-bodied mammals (e.g., Sherman, Tomahawk) easily carried and typically used in multiples over larger spatial scales (as in trapping transects), but larger traps available and most often used to capture special status species
Pitfall trap	Smallest animals	May be used anywhere that animals may be expected to occur. Inexpensive but requires daily maintenance to release trapped animals.	Presence, species identification, relative abundance, capture for possible marking	Widely used for amphibians, some reptiles, and rodents to capture individuals for positive identification. May provide estimates of relative abundance if deployed in several locations. Often used with drift fences to enhance coverage and capture success.

Hair traps	Medium & large-bodied mammals	Useful for structures that are very constrained (e.g., culvert) and identifying species, populations, and individuals; inexpensive but requires expert knowledge and testing (identification of hair samples) may be expensive.	Presence, species identification	Wide range of potential information – from species identification to material for genetic analysis. May constitute “take” for threatened and endangered species. Must check with DF&G and USF&WS prior to use to determine whether a permit is required.
Remotely-triggered camera	Medium and large-bodied mammals, special status species	Useful for constrained crossings (e.g., bridge under-crossing), for monitoring many species, is expensive, logistically challenging (e.g., theft of equipment).	Presence, species identification, relative abundance, identification of attempted or successful crossing, habitat fragmentation	Excellent documentation of species occurrence; may be combined with other methods. Equipment widely available.
GPS and Radio Tracking (collars / tagging)	Large ranging species or non accessible terrain	Useful for characterizing behavior of individuals at roadways and across landscapes roadways.	Behavior, habitat selection and use, movement patterns, delimit territory and home range boundaries	This method requires more variety of expertise, tracking technology, and mapping capabilities. Very expensive.

### *Visual (= Field) Observations*

The most widely-used method to survey for wildlife, visual or field observations may provide the most information on movements and behavior of diurnal and crepuscular animals, and may be essential to understanding animal use or avoidance of crossing structures, including accessory structures such as one-way gates and escape ramps.



Figure 9: Bear track



## Track-count Surveys

Perhaps the most widely-used method to document areas of concentrated animal movement:

- counts of animal tracks left in the substrate (soil, sand, snow) along game trails and similar landscape features
- most effective for large and medium-sized mammals (elk, deer, coyotes, and raccoons) as these species are relatively predictable in their daily and seasonal movements and utilize existing trails in order to save energy and move efficiently across the landscape
- counting and identifying the tracks in these traditional movement corridors provides information on the numbers and species of animals present (e.g., Smallwood and Fitzhugh 1995) but unless the substrate is maintained through time (i.e. refreshed to best document fresh tracks), track-count surveys will not allow an index of abundance.

## Track Plates

Track plates are surfaces made of wood or metal, open or enclosed within a box, dedicated to detecting the presence of and identifying wildlife, especially medium and smaller-bodied animals, through the enhanced detection of their tracks.

These animals are less likely than

larger, heavier animals to leave useful tracks in dry and compacted substrates. Track plates vary in size depending upon the focal species, from one foot square plates that target the smallest rodents, amphibians, and reptiles, to three feet or larger squares for larger mammals. Where species identification is difficult but essential, as in some special status species (e.g., kangaroo rats, lizards) or where bait must be used to lure animals across the plate (e.g., mustelids), the track plate is enclosed within a box (Figure 10) to concentrate movement (e.g., Hilty and Merenlender, 2000). Baited boxes are especially well-suited for carnivores generally (Hilty and Merenlender, 2000) and mustelids (weasels, fisher, marten, otters, and wolverine) in particular (Bull et al. 1992).

In most cases, the track plate is covered with soft, loose sand or soil to facilitate the leaving of easily identifiable impressions, while in others, the track plate may be covered with gypsum or similar material to aid in species identification (e.g., Ng et al. 2004). As with other methods, if the substrate inside the box is replenished and made smooth at intervals, an index of use (tracks per unit time), providing an index of abundance, may be derived.

The advantages to this method are its low cost and relative portability, while its disadvantages include the potential to fail to detect species that are present (e.g., Hilty and Merenlender, 2000) and relatively frequent maintenance interval if baits are used to lure animals on to the plates and in cases where multiple passes may obscure tracks left by previous individuals.

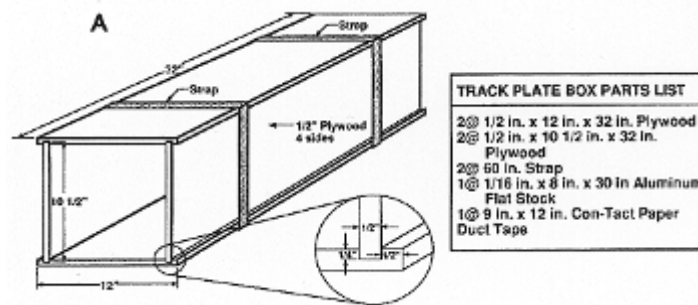

Figure 10: Schematic of a track plate box.

## *Raked Soil*

Conceptually, the use of raked soil is similar to track plates, in that a surface is prepared that will facilitate the leaving of identifiable impressions by animals passing over the raked surface; however, unlike with track plates, the use of raked soil may occur wherever it is most convenient and is not confined to surfaces provided by the biologist. With raked soil, a biologist simply enhances the ability of the substrate (soil or sand) to produce impressions left by animals crossing the substrate. Thus, a biologist selects an area of appropriate substrate (or, in some cases, provides a suitable substrate, as in Figure 11) based upon the presence of existing tracks or an expectation of animal use. This substrate is raked or otherwise prepared to enhance its ability to produce impressions and to aid in estimating the numbers, and to identify, animals that pass per unit time (until the next interval of raking). The advantages of this method are its:



*Figure 11: Installation of raked soil beds adjacent to US-93 in Montana (Montana DOT, 2006).*

- ease of use, as the only piece of equipment is the rake (unless material must initially be provided to create the substrate)
- ability to derive an index of abundance, as the region of raked soil may be checked and prepared at intervals, thus suggesting a rate of use (number of tracks) per unit of time
- ability to detect a wide range of terrestrial vertebrate species, and
- may be widely and repeatedly used, as multiple patches of raked soil may be created and maintained by a single investigator

## *Live Traps*

Live traps come in a variety of sizes, from the smallest Sherman or Tomahawk live traps to medium Havahart traps (Figure 12) to traps large enough to capture bears or elk. Most useful to capture animals for tagging or marking and subsequent release to enable identification of individuals in the field.



Small mammals are typically captured in a “set” of traps, that is, a series of traps set in a line or along some natural feature (e.g., stream bank), whereas medium and large-bodied mammals are more often captured in traps set individually. Traps must be baited with a bait type appropriate to the species of interest, and checked frequently (at least daily) as captured individuals may be easy prey for predators. Food, water, and shelter from the elements may be required.

### *Pitfall Traps*

The pitfall trap consists basically of a glass, plastic or metal container, sunk into the soil so that the mouth is level with the soil surface (Figure 13). Many ground dwelling animals fall into the trap and are unable to escape.

Dry pitfall traps used to collect reptiles, frogs or other amphibians, or rodents are generally jars, tins or drums which are buried in the ground with their lips flush with the ground's surface. The openings are covered by a slightly raised lid or stone, or other object to keep out predators and prevent trapped animals from being overheated (during the day) or drowned (when it rains). Wet pitfall traps contain a solution designed to trap, kill and preserve captured animals. Aqueous solutions used in these traps include alcohol, methylated spirits, trisodium phosphate and picric acid. Pitfall traps are used for sampling animal populations by:

- a. capturing species which are difficult to obtain by other methods
- b. estimating relative abundances and species richness or for catching particular types of animals
- c. determining movement patterns of individual animals.



Figure 13: Pitfall Trap

Derived from  
<http://pecanspiders.tamu.edu/pitfall.htm>

The pitfall trap is a method of estimating relative abundance (e.g., number of animals caught/trap/day) and can produce an index by which several areas can be compared.

To be effective, pitfall traps should be placed along known 'runs', where they are most likely to be encountered by the animals to be trapped, and may be either baited or unbaited. Some use fencing or similar structures to attempt to direct animals into the trap. Pitfall traps must be monitored frequently, as in some cases they may increase the risk of predation for captured animals (e.g., Reading 1989).

### *Hair Traps*

Hair traps are typically baited stations which include a hoop or strand of barbed wire through which animals must pass to access the bait, thereby leaving a sample of hair (Figure 14). The hair sample may be useful in confirming animal presence through examination and may give far greater amounts of information, including gender and individual identification, if analyzed genetically (Woods et al. 1999). Hair traps are not as convenient as are several other methods, require more maintenance, and the hair sample may require considerable expertise to make an accurate identification; therefore, hair traps are typically only used when trying to confirm the presence of special status

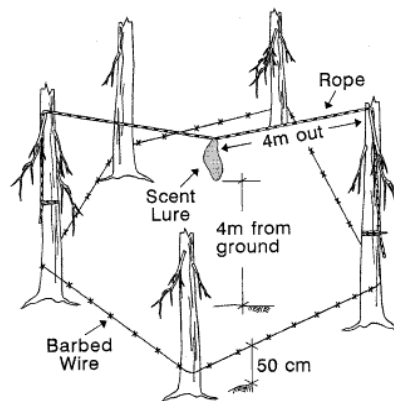

Figure 14: Barbed wire hair trap for bears.

species where other detection methods have failed to provide the desired documentation.

### *Remotely-triggered Cameras*

Remotely-triggered cameras rely on an animal's movement to cause a break in a beam of white or infrared light to take a picture. While either film or digital cameras can be used, digital cameras are more common. The cameras, typically from one to four, are usually deployed to the sides of a potential crossing in areas where crossings occur frequently. The camera placement is determined by the local conditions based upon the crossing location, the species present, and the objectives of the study, and the camera is placed at an oblique angle to the crossing to minimize the chances of detection and to reduce the potential for the camera to deter an animal from entering the crossing. In most cases, it is recommended to shoot three images in a 30 second period, one every 15 seconds, to enhance the probability of obtaining a high-quality image. Remotely-triggered cameras may be used in combination with tracks to verify species presence, behavior, and movement patterns.

Considerations in the use of remotely-triggered cameras include:

- adjust the camera's flash settings to reduce or eliminate red-eye
- confirm the duration of the delay settings (many cameras take photos after a several-second delay, which may be inappropriate for some species)
- consider the requirement of active-infrared cameras to have the beam match the sender and receiver
- make sure that all vegetation has been pruned or removed so that it will not interfere with your images
- be sure to wash your hands before setting the cameras to remove scents that may repel some species
- confirm that cattle or hikers are not using the trail or structure that you're intending to document with your camera array

The use of remotely-triggered cameras is somewhat controversial because their use has both great advantages and great disadvantages. The advantages of remotely-triggered cameras include:

- the images produced provide a permanent record of both the animal (in some cases, both the individual and the species) and of the time when it was present
- may be used to confirm the presence of a special status species, which may be important



*Figure 15: Remotely-triggered Camera.*

for regulatory reasons, in a non-invasive manner

- multiple images may provide an index of the rate of use through time and/or an index of abundance if image quality allows discrimination among individuals
- good for remote locations that cannot be frequently visited as investigators need not return to the site at frequent intervals
- good to document use of crossing structures when other methods are not appropriate

The great disadvantages of remotely-triggered cameras are their cost and need for maintenance: they are frequently vandalized or stolen, may malfunction, and are relatively more costly than are any of the other detection methods (e.g., York et al. 2001, Ng et al. 2004, Sikich and Riley, 2007).

Hilty and Merenlender (2000) provide a comparison of covered track-plates and remotely-triggered cameras deployed in Sonoma County and find that cameras are more effective than are covered track plates at detecting mammalian carnivores. Ng et al. (2004) provide more information on the use of gypsum track plates and remotely-triggered cameras, including vendor information, in assessing wildlife populations. See also York et al. (2001) for more information on remotely-triggered cameras.

Major suppliers of remotely-triggered digital systems include Trailmaster (<http://www.trailmaster.com/>), Reconix (<http://www.reconix.com/>; requires an Internet connection), and the Deer Cam 100 (widely available from on-line vendors), and several models marketed by Bushnell (and available from several on-line vendors) although many investigators fabricate their own (e.g., York et al. 2001).

### *GPS and Radio Collars*

The collection of GPS and radio-collar-based location information is expensive but may be justified in cases of special status species where precise location information is required. This method has been used to study movements of desert bighorn sheep in the Eastern Sierra Nevada (Epps et al. 2005), the San Joaquin kit fox in the San Joaquin Valley (Cypher et al. 2000), and mountain lions in Southern California ([http://www.vetmed.ucdavis.edu/whc/scp/mnt\\_lion.htm](http://www.vetmed.ucdavis.edu/whc/scp/mnt_lion.htm)). Note that some studies have shown that GPS and radio collars may cause lesions and similar injuries to collared animals (Krausman et al. 2004) and caution is advised in their use. The kinds of data generated by radio-collared animals may be most effectively analyzed in a GIS, and may provide insights into timing and frequency of movements, habitats utilized, and effects of roads on behavior and movement patterns.

### **2.2.4 Required Expertise**

For general wildlife surveys and interpretation of existing literature, a B.Sc. degree and relevant field experience is sufficient to identify vertebrate animals and design and implement wildlife surveys, although the detection of rare or secretive species depends to a large extent upon the experience of the observer. California wildlife species are generally distinctive but technicians/biologists with specialized identification skills should be included for special status species that may be difficult to identify in the field. Where special status species occur or where



the only evidence of wildlife consists of tracks or scat, a specialist may be required to consult on identification by sight, sign, and survey methodologies. Coordination with collaborating agencies on planned wildlife surveys is required when determining if you or your office staff has the appropriate expertise to complete necessary surveys. A biologist may be required to have a protocol-level survey permit to conduct surveys for federally-listed species.

For most modeling approaches, and for the mapping of wildlife observations, movement corridors, and the like, the assistance of a GIS technician is likely to be required, and depending upon the rigor of the model, a statistical or mathematical background may be required. Typically, where off-the-shelf approaches are used, a biologist with a bachelor's degree and three or equivalent years of relevant experience, working in collaboration with a GIS technician should be able to identify and map species locations. Where novel approaches are implemented to predict species occurrences or model best minimization or mitigation strategies (e.g., Clevenger et al. 2002), an advanced degree and several years of GIS and statistical training is typically expected.

## 2.2.5 Data Considerations

### *Minimum Observation Data Set*

In order to best document and communicate crossing conflicts, a minimum of set of information for each observation is essential. These minimum data are needed for data reporting, analysis, and interpretation. For reporting, all data sets must answer the who, what, when, and where questions. The core data elements must consist of (*at a minimum*):

1. observer name
2. observer contact information (phone numbers, email address)
3. Caltrans district number
4. county name
5. site location description (county, route, and post mile)
6. site location geographic coordinates (e.g., latitude/longitude)
7. species common name
8. event type (e.g., vehicle-wildlife collision, dead animal, animal crossing road)
9. time of observation
10. date of observation
11. comments (for free-form additional information)

It is worth noting that both federal government (e.g., the National Biological Information Infrastructure, NBII – <http://nbii.gov>) and professional organizations (e.g., Biodiversity Information Standards, formerly known as the Taxonomic Database Working Group, or TDWG – <http://tdwg.org>; and the National Center for Ecological Analysis and Synthesis, or NCEAS – <http://nceas.uscb.edu>) have working groups, which are somewhat coordinated, working on data

standards for species observations, and their recommendations are likely to evolve into state and federal government standards for managing biodiversity data. Data managers should track those efforts as they progress.

## ***2.3 Collaborative Approach***

Previous wildlife crossing efforts have demonstrated the value of enlisting the assistance of county and state highway maintenance and public safety (sheriff departments, Highway Patrol) professionals as well as field staff from state and federal agencies (California Department of Fish & Game, U.S. Fish & Wildlife Service, National Park Service, Natural Resources Conservation Service) and NGOs such as Audubon California and The Nature Conservancy as early as possible in the planning process to provide information on areas of concern. The work in Ventura County, cited in Section 1.6.1, is an especially good example of a highly collaborative approach taken to study and enhance road crossings across an entire, largely urban California county and illustrates the value in consulting with agencies and individuals with a wealth of field experience, and how this experience may effectively inform decisions to enhance wildlife crossings.

As approaches to studying wildlife crossing issues are not standardized, frequent, on-going consultations with agency collaborators should begin at the earliest stages of project planning and continue through post-project assessment to help to:

- identify occurrences of species of management concern within the project area
- provide local knowledge of wildlife mortality, effects on habitat connectivity, cumulative effects, and other concerns
- provide assistance in long-term maintenance and monitoring of crossing sites and structures

Where listed species are involved, remember that standards for maintaining sustainable connectivity, gene flow, and sustainable genetic structures of populations are not well established, though connectivity is an increasing concern of many regulators. Consequently, it is important to consult with U.S. Fish & Wildlife Service and California Department of Fish & Game biologists on connectivity requirements (perhaps as a part of Section 7 consultation or HCP/NCCP planning) early and often. Please consult the associated website ([http://www.dot.ca.gov/hq/env/bio/wildlife\\_crossings/](http://www.dot.ca.gov/hq/env/bio/wildlife_crossings/)) for examples of collaborative approaches to wildlife crossing assessments.

## ***2.4 Use of GIS and Models to Predict Wildlife Passage***

Field studies are often required to assess wildlife populations in a study area; however, many transportation agencies have taken a different approach in an attempt to *predict* where road-wildlife conflicts might occur. Such efforts may be particularly appropriate in areas where new highway construction is planned and where there is scant history of field investigations. Predictive efforts have taken a variety of forms, but most rely upon various modeling approaches to simulate highway crossings. Most models involve the use of Geographic Information System

(GIS) technology, and several studies have assessed the efficacy of a modeling approach (e.g., Clevenger et al. 2002, Frank et al. 2005, Gontier et al. 2006, Malo et al. 2004, and Roe et al. 2006). Model types include:

- GIS using physical environmental attributes including land cover and riparian zones (e.g., Smith 1999, Clevenger et al. 2002)
- GIS using expert opinion – the opinions of agency staff with extensive field experience in a region (e.g., Clevenger et al. 2002)
- GIS using expert literature – analyses based upon published, peer-reviewed scientific studies (e.g., Clevenger et al. 2002)
- GIS using population viability analysis (PVA; van der Grift and Pouwels 2006)
- Statistical models using existing collision data and highway attributes (e.g., Malo et al. 2004)
- GIS least cost path analysis ( see [http://www.geog.ucsb.edu/~gallo/mountain\\_lion/](http://www.geog.ucsb.edu/~gallo/mountain_lion/) for Conception Coast mountain lions and <http://www.wildlands.org/corridor/lcpcor.html> for wildlife movement through corridors in Montana)

In one of the few studies to examine which source(s) of information may provide the best predictions of actual species movement patterns, Clevenger et al. 2002 compared the results of three black bear (*Ursus americanus*) habitat models (expert literature, expert opinion, and empirical habitat data) and found that models relying upon expert literature were best at predicting black bear movements across highways; these results may be relevant to a wide range of mammals.

The development of GIS predictions of wildlife movement corridors and of potential conflicts with highway facilities depends upon a level of technical sophistication that is typically found in a dedicated GIS facility with requisite staff, hardware, software, and training. In the majority of cases, GIS analyses depend heavily upon collaboration, as the several layers (“coverages”) of information required to predict animal locations and corridors of movement are often derived from multiple projects developed by multiple agencies or researchers, and in many cases these were originally developed for other purposes (e.g., the coverage of wetlands developed by the National Wetland Inventory). GIS is an exceedingly useful tool, and may be essential both in an assessment environment where it may predict the locations of wildlife corridors, as well as in a data management environment, where it may help to accumulate, maintain, analyze, and report on wildlife observation and related geo-spatial data (e.g., road-kill reports, track plate/raked soil/remotely-triggered camera locations, etc.).

#### **2.4.1 Large-scale Prioritization of Wildlife Crossing Corridors**

The development of a strategy to evaluate wildlife corridors statewide, including a prioritization method, is currently being explored. Locations identified as having the greatest likelihoods of animal-vehicle collisions with large animals will most likely be given the highest priority in order to ensure driver safety. Locations identified as impacting endangered or threatened species will also be given high priority due to regulatory and stewardship obligations. Statewide modeling and mapping of wildlife corridors will allow the Districts to visualize the regional



goals associated with safety and connectivity improvements for regional planning and prioritization.

The text box below provides an excellent example of a statewide prioritization effort of wildlife crossings from Florida (derived from Smith 1999). In Smith's (1999) analysis, nationally- and regionally-significant conservation areas and riparian corridors received the highest priority for mitigation measures.

## *Using GIS to Prioritize Florida Wildlife Crossings*

An innovative project in Florida (Smith 1999) specifically addresses the question of how to set wildlife crossing priorities across large spatial scales. Smith's work utilized a GIS approach to prioritize road crossings by assessing their "overall ecological impact." Ecological effect was determined by ranking roads according to several categories of ecological and planning criteria. Important environmental factors for prioritizing relative effect of roads on lands with conservation value were established through a survey conducted at a Florida Department of Transportation sponsored workshop on road-related wildlife mortality. Survey respondents were asked to rank various criteria associated with prioritizing sites for the location of underpasses on Florida roads in order to alleviate road-kills and to provide ecological linkages. Eleven elements were identified and ranked as follows:

1. Chronic road-kill sites
2. Known migration/movement routes
3. Identified hot spots of focal species
4. Landscape linkages (designated greenways)
5. Presence of listed species
6. Identified strategic habitat conservation areas
7. Riparian corridors (with potential for retrofitting existing structures)
8. Core conservation areas
9. Presence of separated required ecological resources (e.g., a forest patch and ephemeral wetland breeding area for amphibians that is separated by a highway) for a species or set of species
10. Public ownership (or in public land acquisition program) vs. private lands
11. Potential to be included in proposed road improvement project

(Criterion 2 was modified to apply to wildlife movement patterns typical for this region; Criterion 8 was divided between two other criteria, public lands and strategic habitat conservation areas due to the severe overlap with other criteria; and Criterion 9 was dropped due to a lack of data for identifying the locations of these areas).

These elements were used to create a rule-based GIS model which was used to rank priorities for mitigation actions. The model assigned the highest priority to road segments within nationally- and regionally- significant conservation areas and riparian corridors. Results suggested that the keys to mitigation of impacts of highways and automobile traffic on wildlife populations and ecologically sensitive areas include programming of wildlife crossing mitigation into road projects and identification of existing structures. Several road projects and suitable existing structures were identified within highly ranked ecological interface zones and the locations of additional needs (underpasses, culverts, etc.) were identified and prioritized.

## ***2.5 Analyze and Interpret Data to Evaluate Crossing Potential***

Once you have collected all the necessary data from your surveys to round out your baseline information, it is important to evaluate your site to understand the existing crossing functionality of your project area. The following topics should be considered when making this final evaluation of your baseline.

### **2.5.1 Areas of High Connectedness**

Areas with unusually high measures of connectedness, for example areas that may be easily reached by dispersing individuals or individuals searching for mates, are consequently also areas of relatively high corridor potential, as reductions in connectedness have been shown to reduce survivorship and productivity (e.g., Smith and Hellman 2002). Such sites may be especially important for special status and rare species, as these are species that have already been demonstrated to have small populations. Additional sources of mortality, or reductions in productivity, may constitute cumulative effects as per CEQA, further reduce the abundance of these species, and lead to mitigation efforts. Areas of high connectivity may be relatively difficult to define in nature, however, as their delineation implies a level of local knowledge that is not often available. Further, assessments designed to document areas of high connectedness must be regional in nature and include both adjacent as well as more distant habitat patches upon which animals depend at different times of the year (e.g., breeding vs. wintering) or during different phases of the life cycle (e.g., adult summer range vs. juvenile dispersal corridors). Consult with agency collaborators early in the planning process to begin to identify affected areas and species.

### **2.5.2 Adjacent important conservation areas**

If a highway facility bisects adjacent areas with known conservation importance, it should receive priority in wildlife crossing planning. For example, if a highway passes through a region with a National Wildlife Refuge on one side and a State Wildlife Area, Audubon Sanctuary, or other protected area with high conservation importance on the other, it should be afforded high priority to ensure safe passage of vertebrates between the adjacent protected areas. Such adjacent areas received the highest priority ranking in Smith's (1999) GIS-based prioritization scheme in Florida (see text-box, above).

### **2.5.3 Separation of seasonally-used habitats**

When assessing the effects of a transportation facility improvement, it is important to consider life cycle needs and movements between essential, seasonally-used habitats. Many animals may move seasonally between two adjacent or nearby habitat patches along or across roads, as during migration, dispersal, or for breeding, and accommodating these movements is essential to many species' survival. For example:

- Salamanders require streams, ponds, or wetlands for breeding, typically during the winter, but spend most of their lives underground in upland areas adjacent to the

breeding areas. California tiger salamanders, a federal and state-listed species, spend most of the year in underground burrows and descend to ponds with the first heavy rains in winter (Twitty 1941). Tiger salamanders are subject to high rates of mortality when they cross roads between their burrows and breeding ponds (Twitty 1941, Barry and Shaffer 1994).

- Western pond turtles occur throughout the Central Valley of California in a variety of natural and man-made habitats and may move among sites if their preferred moist conditions deteriorate due to seasonal drought (Germano and Bury 2001).
- Toads and some frogs require wetlands or ponds for breeding but spend most of the year in adjacent upland areas; Carr and Fahrig (2001) found that around ponds in Ontario, Canada, mobile frog species are more vulnerable to road mortality than are less mobile species. Findlay and Houlahan (2000), also working in Ontario, found widespread reductions in species abundances of multiple vertebrate taxa extending 2 km outwards from wetlands and showed that road density was strongly correlated with these reductions.
- Desert bighorn sheep move among isolated mountain ranges in southeast California in the course of a year (Epps et al. 2005).
- Deer in northeast California move, often in large numbers, from summer to winter ranges in the autumn and back again in the spring (Ford 1976).

Amphibians, generally, are known to be especially vulnerable to mortality as they attempt to cross roads in their annual movements to and from their breeding locales (e.g., Twitty 1941, Barry and Shaffer 1994, Marsh et al. 2005, Langton 2002), so for example, a section of road crossed by breeding Shasta or California tiger salamanders would be a priority for crossing enhancements.

## ***2.6 Existing Connectivity Attributes/Infrastructure***

Roadways may interact with wildlife in complex ways, effectively repelling some species during some seasons, acting as movement corridors during other seasons (Clevenger et al. 2003), and attracting others indirectly through favoring the growth of preferred food plants (Boarman et al. 1997, Forman and Alexander 1998). Roadways that are straight, with good sight-lines and adequate speed control are likely to be more permeable (i.e. have fewer wildlife crossing conflicts) than curved roads with vegetation or other obstacles to sight-lines in the right-of-way. Especially high rates of safe passage are provided by bridges and viaducts spanning canyons as these allow very high levels of connectivity and little if any impediment to wildlife movement, while especially low rates of safe passage are provided by a concrete median without small openings near the ground. Concrete median barriers enhance driver safety by separating opposing lanes of traffic, but provide low permeability to wildlife (Clevenger and Kociolek 2006). Between these two extremes are culverts, which have been shown both



*Figure 16: Culvert under rural paved road in the Sierra Nevada*

within (Ng et al. 2004) and outside of California (Yanes et al. 1995, Clevenger, Chruszcz, and Gunson 2001, Krawchuk et al. 2005, Taylor and Goldingay 2003) to provide safe passage for a wide variety of organisms. Culverts, although in most cases originally installed to provide continuity for water flow beneath roadways (Figure 16), may provide especially efficient wildlife crossings if modified from their original designs. The subject of modifying existing structures for enhanced wildlife crossing is discussed in [Section 3.3](#).

## 2.7 Road-side Vegetation

Road-side vegetation interacts with wildlife crossing in complex ways (e.g., Groot Bruinderink and Hazebroek 1996, Boarman et al. 1997, Clevenger and Waltho 2005). Many herbivores, including such diverse organisms as tortoises (Boarman et al. 1997) and deer (Feldhamer et al. 1986), tend to be attracted to roads due to the increase in forage that may occur there. Most large-bodied mammals are more inclined to approach roads and to use crossing structures if vegetation is close-by, minimizing the distance to cover, but mountain lions are less likely to use crossing structures if the distance to cover is minimized (Clevenger and Waltho 2005). Thus, in crossing assessments, the habitat preferences, including sources of both food and cover, of the animal species of management interest must be carefully considered within and along the right-of-way. Include a discussion of road-side vegetation in your baseline assessment.



Figure 17: Encourage use of native plants along roadsides (Caltrans photo)

## 2.8 Traffic Characteristics

The primary characteristics of traffic, i.e. volume and speed, interact in complex ways with wildlife crossing, and studies of different animals under different conditions or in different locations have reached different conclusions. Where both traffic volume and traffic speed are high, most animals perceive the roadway as a barrier and do not attempt to cross, but decreases in traffic volume may lead some animals to perceive the roadway differently and to attempt to cross. Often, decreases in traffic volume are accompanied by increases in traffic speed, and high speeds can lead to increased rates of animal-vehicle collision.

Field assessments must include evaluations of traffic characteristics; for example, Ng et al. (2004) found that decreases in traffic volume in more rural portions of Ventura County lead to an increase in the frequency of animal highway crossing and this increase in rate of crossing lead to an increase in the rate of vehicle/wildlife collisions (i.e. the



Figure 18: Motorist warning sign

barrier effect of the roadway was less evident to local wildlife when fewer cars were on the road). Conversely, another study from Ventura County found that the greatest incidence of wildlife/vehicle collisions occurred on the busiest stretches of the most heavily-used roads (Cavallaro et al., 2005), a result consistent with that observed by Clevenger et al. (2003) on their study site in Alberta, Canada and by a study of all vertebrates by Lodé (2000) for a roadway in France. Case (1978) found that traffic volume was not significantly correlated with the number of road-killed animals, but that the number of road-killed animals was significantly correlated with vehicular speed.

Thus, the relationships between traffic characteristics and rates of vehicle/wildlife collisions are complex, and these relationships are further compounded by daily and seasonal differences in both animal movement and traffic characteristics. Thus, no overall generalizations are possible, and Department personnel should be aware of these complex relationships and are encouraged to assess the local conditions (traffic characteristics plus wildlife behavior) to best accommodate local needs.

### **2.8.1 Daily and Seasonal Rates of Crossing**

Your baseline assessment should establish patterns in diurnal and seasonal rates of wildlife crossing, as typical daily or seasonal animal movements may result in large differences in rates of crossing, and these differences may, in turn, present quite different public safety and wildlife mortality considerations. Examples of temporal effects on wildlife movements and crossing conflicts include:

- Deer undercrossings on U.S. 395 were installed due primarily to increases in rates of animal-vehicle collisions during spring and fall deer migrations (Ford 1976).
- Cavallaro et al. (2005) found a pattern of an increased frequency of vehicle-animal collisions during the late night or early morning hours in Ventura County.
- Twitty (1941) and Barry and Shaffer (1994) found that California tiger salamanders had far higher rates of mortality while crossing the road between their aestivation sites and breeding pond on the campus of Stanford University.

Field assessments should take into account and document these temporal effects.

### **2.8.2 Relative Visibility/Compromised Line of Sight**

The baseline assessment must consider potential effects due to limited visibility, as sharp curves, undulations in the road surface, and roadside vegetation reduce a driver's line-of-sight, reduce driver response time, and may increase the risk of collision should an animal appear on the roadway (Hedlund et al. 2004). These considerations may be especially important for ungulates and other large-bodied animals as they present the greatest risk to driver safety. Practitioners must compare the conditions as they currently exist in the project area to those that would exist should the project be built and assess whether the new conditions would affect the probability of crossing. The effects of road-side vegetation on animal behavior must also be considered, as

road-side vegetation has been shown to both attract and repel wildlife, depending upon the species (see Section 2.7).

## ***2.9 Identify Limitations of Baseline Data***

In some cases, there may be insufficient information to thoroughly evaluate the pre-project conditions and therefore the potential effects of a road project on wildlife populations and/or habitats. A lack of information may be due to limitations on:

- data availability – there may have been no prior field work done in the project area or the results of prior investigations are unknown or unavailable to Caltrans staff
- data collection – there may be limits on access, lack of time, seasonal effects or other constraints that prevent or reduce the effectiveness and information content of pre-project surveys that would help to establish baseline conditions
- data analysis – there may be conflicts and incompatibilities with prior data collection efforts or changes in environmental conditions that render prior data ambiguous and confound efforts to utilize existing data to set project baselines
- data interpretation – there may be ambiguities in prior or current data sets that affect your ability to interpret wildlife presence, abundance, and movement patterns evaluate crossing.

It is essential to become familiar with the species of management interest and to make sure that your field surveys are conducted during seasons when the focal species are known to be most active. Many vertebrates have periods of relatively high rates of movement, whether for dispersal, breeding, or migration. For example, if your surveys are focused on potential project effects on salamander movements, it would be essential to conduct field work during the late fall, winter, and early spring when amphibians are moving between summer (non-breeding) and winter (breeding) portions of their range. The U.S. 395 underpasses in Lassen and Sierra counties were installed to enhance habitat connectivity and increase driver safety during spring and autumn migrations of mule deer (Figure 21; Ford 1976). Know the life cycle of your focal species and schedule your field work to ensure that efforts to estimate crossing effects occur when crossings, or physical or behavioral impediments to crossing, are most likely.

### 3 Project Effect Assessment

Now that you have established your baseline understanding of wildlife crossing at landscape, regional, and local scales, it is time to conduct your assessment of what effects the proposed project may have. In this assessment, it is important to focus on effects associated with the direct, indirect, temporary, and cumulative effects on your focal species, habitat, or habitat connectivity. Based on the life-cycle needs of particular species, different project elements and design features can create different effects. In order to get a clear picture of the effects of a proposed project on wildlife crossing in your project area, consider your baseline and the change in baseline should the project take place. Compare how wildlife is currently crossing to how it might utilize the area or cross the highway facilities should the proposed project occur.

A template for reporting has been developed to help to guide you through the process of documenting this assessment and is available at the wildlife crossing website ([http://www.dot.ca.gov/hq/env/bio/wildlife\\_crossings/](http://www.dot.ca.gov/hq/env/bio/wildlife_crossings/)).

Table 4, below, provides an overview of elements to consider when conducting a wildlife crossing assessment. All projects must consider NEPA and CEQA regulations. Invariably, the steps described below arise in every project and should be included in the effect assessment. Where listed species are present, additional steps are typically required.



Table 3: Planning Process Stages and Relevant Questions to Consider

Planning Process Stage	Relevant Questions to Consider
Baseline Information	What information is available? Do I have enough information to assess wildlife crossing?
Regulatory Context	What regulations apply in this instance?
Coordination	Have I worked with the PDT to develop the proposed mitigation measure, required schedules or timelines that I am recommending in my technical document? Can my recommendation be implemented? What are the adjacent land uses? Are landowners amenable to this connectivity enhancement? Have you coordinated with the appropriate agencies, including other transportation agencies (e.g., railroads)?
Effect Analysis	What barriers to connectivity exist? What assumptions am I making? Are known effects cumulative?
Mitigation	What are the goals of this mitigation recommendation? How does my recommendation contribute to solving problems? What regulations authorize the mitigation recommendation? Does my recommendation adequately address mitigation goals? If not, are future efforts or other efforts by other entities going to address these? Are the designs structurally feasible and meet engineering standards? Have alternative mitigation measures been explored?
Maintenance/Monitoring/Adaptive Management	What are the anticipated maintenance needs of your recommendation? Have these been discussed with maintenance? What funding and resources are available to implement post-project monitoring?

### ***3.1 Potential Temporary or Construction-Related Effects***

Although temporary, project-related construction activities may effect existing or potential wildlife crossing and these effects may be sustained beyond the construction interval. Construction effects such as noise, increased vehicle traffic, removal of vegetation, increases in dust, staging of equipment, and the construction of access roads may all result in reductions in habitat, either through direct habitat alterations or due to behavioral responses by animals to construction activities (Trombulak and Frissell 2000, Forman and Deblinger 2000). As an example, Welsh and Ollivier (1998) found that highway construction reduced amphibian abundances in streams following storm events that flushed fine sediments into their study sites in Humboldt county. Thus, potential effects due to construction activities should be considered in

project planning, especially when special status species are believed to exist within a project area, and mitigation measures for anticipated impacts must be proposed.

### ***3.2 Potential Direct and Indirect Effects***

It is essential to consider how your project may effect wildlife movement within, along, and across the right-of-way, especially when special status species may be involved. Be sure to consider both the potential for roads to attract wildlife, and thereby increase its susceptibility to effects (e.g., desert tortoise attracted to vegetation growing in the right-of-way; Boarman, Sazaki, and Jennings 1997) and the potential for the road to repel wildlife, and to serve as a physical or behavioral barrier to movement (e.g., coyotes and bobcats in Ventura county; Riley et al. 2006). Your considerations should include both direct and indirect effects. Direct effects include loss of habitat and blocking of movement corridors, while indirect effects include the growth of vegetation preferred by herbivorous species, indirectly increasing their susceptibility to vehicle strikes or an increase in traffic-related noise levels, with consequent effects on birds and some mammals (Figure 19). Also consider the larger picture – evaluate how your project may interact with other existing and planned projects and habitat alterations in the region to add to effects on wildlife and result in cumulative effects as per CEQA (see Section 3.5, below). Especially consider whether you may have a “source habitat” in the project region (sensu Pulliam 1988), as these habitats may be especially important for regional population persistence. Source habitats are those with a surplus of reproductive output, from which the surplus individuals may disperse to “sink habitats” which may have a deficit of reproduction. Although difficult to document in nature, your consultations with agency and other biologists may reveal habitat areas that are known to be especially important to regional persistence of species of management importance, and effects on these habitats may have widespread deleterious consequences.

You must make a determination as to whether the project is or is not likely to effect wildlife movement by estimating pre-project rates of crossing by species of management interest and comparing these estimates to those expected given the project specifications. Where effects are expected to be substantial, you must suggest an avoidance, minimization, or compensatory mitigation strategy.

### ***3.3 Changes/Effects to Existing and Potential Wildlife Crossing***

Your project effect assessment must consider how the project might affect existing as well as potential crossing behavior. Include in your assessment potential behavioral changes in wildlife associated with proposed improvements which may result in avoidance of the highway facility, thereby reducing crossing events. Estimate the magnitude of the reduction in the rate of crossing by the species of interest, and use this estimate to assess the effects of the project on the relative permeability of the highway compared to pre-construction conditions. Be sure to consider major changes such as the addition of lanes and/or median barriers on rates of passage as well as less conspicuous changes such as the deterrence effect of added lighting and increased traffic noise, as many animals perceive noise and light as sources of disturbance and are known to be sensitive to these and similar disturbances (van der Zande, ter Keurs, and van der Weijden 1980, Garber

1995, Reijnen 1996 and 1997, Forman and Alexander 1998, Forman 2000, Bull 2001, Bjurlin and Cypher 2003). Your mitigation suggestions should address these and related impacts associated with both the anticipated infrastructure (primary effects due to road widening, etc.) and resulting (secondary effects due to increased traffic, noise volume and duration, etc.) changes.

### **3.3.1 Change in Infrastructure**

Changes to infrastructure may affect rates of wildlife passage, and the potential magnitude of these effects depends upon the: 1) type of infrastructural change, 2) species of interest, and the 3) existing rate of crossing in the project area. Infrastructural changes may present both opportunities and barriers to wildlife passage in the project region. For example, if the infrastructural changes are or include culvert modifications, the new culverts may provide an opportunity to enhance existing rates of crossing and decrease rates of vehicle-animal collisions if the new culverts are larger than the existing culverts and include wildlife ledges, fencing, and vegetation to enhance their use. In contrast, if the infrastructural changes include the addition of median barriers or guardrails, and these are to be installed in an area of known animal crossing, these may substantially increase the risk of vehicle-animal collision, inadvertently trap animals inside the right-of-way, and decrease rates of crossing, resulting in the need to mitigate these potential impacts. Similarly, if the change in infrastructure increases the number of lanes of traffic, this change, too, may be expected to increase crossing conflicts and may require mitigation measures to offset the anticipated effects.

### **3.3.2 Changes in Traffic Patterns**

You must consider how project-related changes in traffic patterns may effect wildlife crossing. This assessment should take into account both diurnal as well as seasonal changes in traffic. If the projected annual average daily traffic (ADT) or the rate of truck use is expected to increase due to the project, you must estimate the resultant effect on pre-project vs. post-project rates of wildlife crossing and vehicle-animal collisions. Similarly, if night-time traffic volumes are expected to increase compared to pre-construction volumes and this increase in traffic volume may lead to increases in rates of vehicle-animal collisions, you will need to suggest measures to mitigate for these anticipated impacts. In the case of special status species, these considerations may be essential components of estimates of mortality and population persistence.

Changes in traffic patterns may be difficult to assess, and it is generally advisable to consult with your traffic engineer on existing and project-related changes traffic volumes.

### **3.3.3 Changes in Visibility**

Your evaluation must describe any anticipated changes in visibility, especially changes in lines-of-sight, as reductions in visibility may decrease driver response times to animals on the road surface and increase the probability of a collision (Hedlund et al. 2004). Line-of-sight reductions may result from grade/elevation changes, increases in road curvature, or increases in the obscuring effects of vegetation and each of these factors must be considered for effects on driver

visibility. If you anticipate significant effects on driver visibility, you must suggest measures to mitigate for these impacts.

### 3.4 Secondary Effects

Any of the changes described in the preceding sections of the manual may affect your focal species, and you should be prepared to document and to estimate the magnitudes of the anticipated effects. In addition to the primary effects on movement, roads have been shown to have many secondary effects that may be less apparent but no less important to population viability and persistence. When considering secondary effects, consider the “road-effect zone” of Forman and Alexander (1998), that is, the area over which significant ecological effects extend outward from a road (Figure 19).

The range of secondary effects may be large, and includes:

- avoidance of highway corridors by vertebrates due to vehicular noise (van der Zande, ter Keurs, and van der Weijden 1980; Reijnen 1996 and 1997; Forman Reineking, and Hersperger 2002)
- avoidance of highway corridors by vertebrates due to reduction in vegetation (Clevenger and Waltho 2005)
- attraction to roads due to increases in preferred vegetation (Boarman, Sazaki, and Jennings 1997)
- increased rates of predation adjacent to highway infrastructure (the “predator effect”; Hartmann 2003)

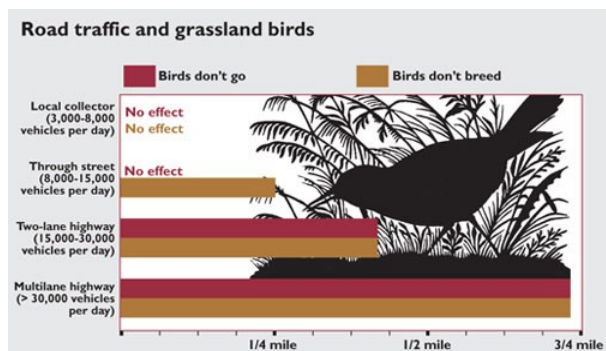

Figure 19: Ecological “road effect” zone for birds.

Derived from <http://www.harvardmagazine.com/online/050529.html>

You must be familiar with the specific habitat requirements, behavioral responses, and movement patterns related to life-cycle stages of your focal species to be able to adequately assess potential secondary effects of a highway project. Where special status species are present, you must examine potential secondary effects of the project (e.g., attraction or avoidance due to changes in vegetation) to estimate effects on the abundance and distribution of the focal species and any potential for these effects to increase mortality and reduce population persistence. Consultations with agency wildlife professionals in the area may help to identify potential significant secondary effects, and your assessment of secondary effects may also help to document cumulative effects, considered below.

### 3.5 Cumulative Effects

As part of your project effects assessment, you must consider how the potential effects of the proposed project may add to existing as well as reasonably foreseeable probable future effects on

wildlife, including wildlife crossing, in the area. Though such assessments are required under both NEPA and CEQA, it may be difficult to determine when a threshold of significant cumulative effects is exceeded (e.g., Theobald, Miller, and Hobbs 1997). For a cumulative effects assessment, you must take a regional view of existing conditions (land use, conservation areas, known or predicted wildlife corridors, areas of relatively natural vegetation) and place your project into this regional context to determine whether anticipated effects on crossing the right-of-way, changes in traffic, and other effects related to the proposed project will significantly add to existing effects on wildlife in the region. Cumulative effects analyses are essential for special status species and formally designated critical habitats, as NEPA and CEQA seek to eliminate significant effects and require that any potential effects be mitigated.

Wildlife crossing effects contribute to overall effects on species populations and habitats through a variety of mechanisms, including:

- isolating populations, with potential reproductive and genetic effects
- reduce available habitat indirectly through vehicle disturbance and road avoidance
- direct loss of habitat
- preventing essential movement (for foraging, breeding, dispersal)

The following eight steps, modified from the Caltrans Standard Environmental Reference, serve as guidelines for identifying and assessing cumulative effects:

1. Identify the species and habitats to consider in the cumulative effect analysis by gathering input from knowledgeable individuals and reliable information sources. This process is initiated during project scoping and continues throughout the NEPA/CEQA analysis.
2. Define the geographic boundary for each species to be addressed in the cumulative effect analysis.
3. Describe the current status and the historical trends of each species.
4. Identify the direct and indirect effects of the proposed project that might contribute to a cumulative effect on the identified species and/or habitats.
5. Identify the set of other current and reasonably foreseeable future actions or projects and their associated environmental effects to include in the cumulative effect analysis.
6. Assess the potential cumulative effects.
7. Report the results of the cumulative effect analysis.
8. Assess the need for mitigation and/or recommendations for actions by other agencies to address a cumulative impact.

Your analysis of cumulative effects will need to take into account past, present, and reasonably foreseeable future actions and their effects on the species of management interest as well as the potential effects due to the proposed project. GIS may be helpful in this type of analysis by enabling you to integrate aerial photography with land use and proposed project shape files in an evaluation of cumulative effects on wildlife crossing and habitat connectivity.

## 4 Selecting Avoidance, Minimization, or Compensatory Mitigation Measures

Once a field assessment has confirmed the presence of sensitive species or habitats or concluded that a project has potential wildlife crossing effects, it is required to suggest appropriate avoidance, minimization, and/or compensatory mitigation strategies to address the impacts.

In most cases, the choice of strategy will depend upon:

- the type of project (new construction, retrofit, road resurfacing, etc.)
- integration with other project goals
- regulatory considerations (special status species, critical habitats)
- public safety
- public outcry over conspicuously high rates of mortality along well-traveled routes
- the focal species group, and
- additional site-specific considerations such as terrain, engineering feasibility, and cost

Some of these are in response to legal requirements (see Table 1), but others, notably public safety and public outcry, are matters of prudent public policy. On policy issues, be sure to consult with engineers and management.

Once you have considered the above, define the intended goals of the avoidance, minimization or compensatory mitigation actions you are going to consider. In a way similar to the baseline evaluation, ask yourself the question of what needs to be done and why. When doing so, consider if the intended result of your measures includes the following:

- reduction in animal-vehicle related mortality
- increase habitat connectivity/reduction in habitat fragmentation
- improved permeability of a crossing structure
- increased genetic exchange
- reduction in predator influence created by facility
- increased public safety

Lastly, before developing your avoidance, minimization, and mitigation measures evaluate why the Department should pursue such measures. Revisit the laws and regulations that apply to your situation to help justify and support the use of public funds for these measures.

### ***4.1 Project Types and Wildlife Crossing Considerations***

According to state and federal statutes, projects are generally required to avoid environmental effects if possible, minimize these impacts if avoidance is not possible, and compensate for what can't be avoided or minimized. Thus, the first consideration when project effects are expected is to consider alternative project designs that will avoid anticipated impacts. Where avoidance is

impractical or impossible, project modifications to minimize effects should be explored. And finally, where neither avoidance nor minimization is possible, compensate to mitigate for anticipated impacts.

The choice of mitigation action will depend upon the goals related to reduce the effects of a specific project type. For example, where the mitigation goal is to reduce mortality of amphibians crossing from breeding to summer range (e.g., due to regulatory considerations or public outcry), the best mitigation option may be to install culverts, with an associated substantial fencing system to direct animals to the culverts and prevent them from crossing the road. Where the primary goal is to restore or maintain habitat connectivity and benefit the widest range of species, the best option may be to build a large crossing structure (wildlife bridge or underpass), given cost constraints, and may be enhanced by partnering for the acquisition of conservation easements or land purchases to conserve the wildlife crossing in perpetuity.



Figure 20: Salamanders exiting culvert. Photo: FHWA Critter Crossings website

## ***4.2 Infrastructure Improvements to Wildlife Crossing***

When evaluating infrastructure alternatives to improve wildlife crossing it is important to note that one size does not fit all. Depending upon the goal(s) of your structural improvement and focal species that will be using it, different sizes, approaches, substrates, lighting, moisture, temperature, water flow, fencing mesh, and height will need to be considered.

### **4.2.1 Wildlife Bridges/Overpasses**

Wildlife bridges are vegetated structures that are designed primarily for the passage of large-bodied mammals, but they have been demonstrated to be used by all taxa and functional groups (e.g., Clevenger and Waltho, 2005).

- Typically the highest cost option, these are used mainly when wildlife/vehicle collisions are relatively frequent and result in severe injuries or fatalities, or when special status species or large-bodied mammals are involved (e.g., grizzly bears, wolves; Cavallaro et al. 2005)
- May serve as intermediate habitat for smaller-bodied organisms
- Maintain habitat connectivity
- Reduce collisions and facilitate crossing, especially when used in conjunction with vegetation and fencing to guide animals to over-crossing
- Substrate and vegetation on the overpass should match that of surrounding landscapes



- Vegetation is often used to provide a sight and sound barriers to encourage use by disturbance-shy animals
- Fencing and vegetation are used to direct animals to the overpass

#### 4.2.2 Wildlife Underpasses

Wildlife underpasses are structures that are constructed to allow safe passage of large-bodied animals. In periods of seasonal migrations, especially deer in California, the movements of animals across roadways present serious public safety conflicts. There is a series of three wildlife underpasses on U.S. 395 in Lassen and Sierra counties that were constructed between 1976-1978 to reduce deer-vehicle collisions (Ford 1976; Figure 21). As with wildlife bridges, these large structures may be primarily intended to benefit large-bodied animals, but simultaneously provide safe passage to a wide variety of small and medium-bodied animals, too, and are in most cases constructed with fencing to direct animals to and through the structure (Figure 21). The openness ratio is critical to use by the intended species, as a too-low underpass may be perceived as a tunnel, especially by deer. A large, open underpass with an openness ratio  $> 0.75$  is preferred (Cavallaro et al. 2005).



Figure 21: Wildlife Underpass, Sierra County. Photo courtesy Brian Ehler, Calif. DF&G

#### 4.2.3 Culverts

Culverts are used in both upland and riparian settings and come in a variety of sizes, from small pipes to large, pre-cast concrete boxes, but are typically galvanized steel, aluminum, PVC, or concrete pipes of various diameters.

Existing culverts were in most cases originally designed and installed to enhance drainage and thus typically benefit mostly smaller-bodied vertebrates, including both aquatic (amphibians) and terrestrial (small mammals, snakes, lizards, tortoises) species, although they have been demonstrated to benefit a variety of vertebrate species (Clevenger et al. 2001, Ng et al. 2004). Larger culverts may benefit a larger number of species including even large-bodied mammals like deer and bear (e.g., Cavallaro et al. 2005).

#### *Openness Ratio*

Some studies have found that the structure openness ratio, defined as a structure's (height x width)/length, is important for large and medium-bodied mammals (e.g., Ford 1976, Cain et al. 2003, Clevenger and Walther 2005). As the openness ratio is a function of structure length, which corresponds to the width of the roadway, the appropriate structural dimensions will be determined by road width. A relatively large openness ratio (i.e.  $>.75$ ) may enhance a structure's use by large mammals by allowing sight through a crossing structure, as well as by providing more natural lighting conditions.



Best practices include:

- Even in riparian zones, culverts should be built or modified with dry ledges for use by water-shy organisms (Figure 22); these ledges should be constructed to be able to withstand flood events.
- Most mammals prefer to see through to habitat on the opposite side of the culvert – the culvert should not appear as a cave or burrow; the culvert openness ratio is important (see below). However, weasels and amphibians do not require such line of sight through the culvert (Clevenger et al. 2001; Dodd et al. 2004)
- Box Culverts are often deployed and documented as effective in both riparian and upland situations, especially when used in conjunction with fencing to guide (or “funnel”) animals in to the culvert (Cavallaro et al. 2005, Taylor and Goldingay 2003, Ng et al. 2004)
- Substrate in floor of culvert demonstrated to be important, and ideal substrate is believed to be that of the surrounding habitat (e.g., Dodd et al. 2004)
- Routine maintenance of existing culverts may in some cases be essential to maintain connectivity for species depending upon these culverts for safe crossing (e.g., Dodd et al. 2004). “Hanging culverts” are often created following periods of intense precipitation, and appropriate monitoring and maintenance should ensure access to and through the culvert; boulders, rip-rap or other coarse materials should not be used to maintain the aprons at the ends culverts used for passage by small-bodied animals, as rough materials may be difficult to negotiate for small bodied and hoofed animals.



Figure 22: Riparian culvert with rock ledge (derived from FHWA website)

A recent (November, 2006) publication that examines the use of culverts for fish and wildlife passage in greater detail is available from the Arizona Department of Fish & Game website (<http://www.azgfd.gov/hgis/pdfs/CulvertGuidelinesforWildlifeCrossings.pdf>).

#### 4.2.4 Fencing

Fencing is often used in conjunction with other crossing structures to exclude animals from portions of roadways where their crossing is not desired and to direct or “funnel” animals toward a desired crossing location such as a pipe, culvert, or underpass (Figures 21, 24). Exclusion fences have been used for diverse groups including amphibians, reptiles, deer, and elk (Aresco 2005, Gibbs 1998; Figure 23). Exclusion fences may, in some cases, act to trap wildlife within the right-of-way (Clevenger and Kociolek 2006), and must be



Figure 23: Desert Tortoise barrier fence (William Boarman photo)

built with one-way gates (e.g. Ford 1976; Figure 25), swing gates, or escape ramps (Figure 26) to enable animals otherwise trapped in the right-of-way to escape. To prevent small-bodied animals from entering the right-of-way through fences, fencing should be buried, or otherwise secured in the ground, and should be of a mesh size that will not trap animals in the roadway (see Figures 21, 23).

Fence design, height, and materials are important considerations, as these interact with species type to determine what kind, and how much fencing should be used in a specific setting (Table 5). The ends of fences should be located in a region that deters wildlife, such as a steep change in grade or an urban area, as this minimizes the potential for animals crossing the road to be trapped inside the right-of-way, and wherever possible, fences should only be used in conjunction with a crossing structure, as fences otherwise act as barriers to movement, with potentially serious consequences (Jaeger and Fahrig 2004).



Figure 24: One-way gate in Banff National Park, Canada

Important considerations for specific applications are described in Table 5, design specifications for desert tortoises are given in the Appendix, Section 7.2., and additional information will be provided on the associated website

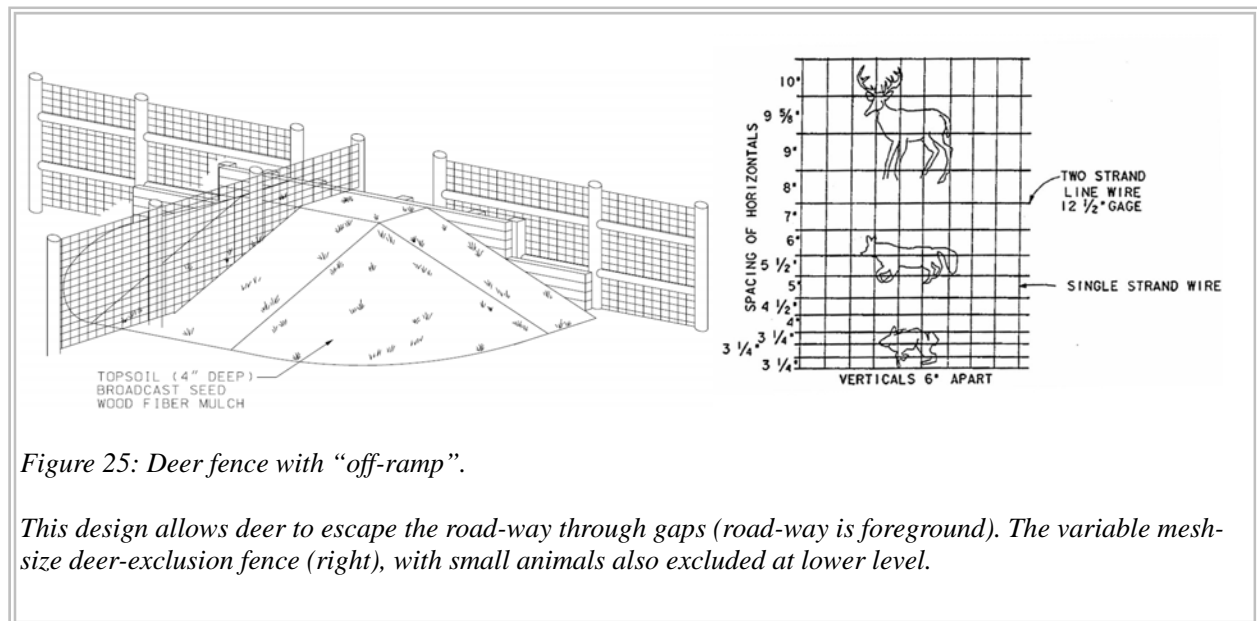

Figure 25: Deer fence with “off-ramp”.

This design allows deer to escape the road-way through gaps (road-way is foreground). The variable mesh-size deer-exclusion fence (right), with small animals also excluded at lower level.

([http://www.dot.ca.gov/hq/env/bio/wildlife\\_crossings/](http://www.dot.ca.gov/hq/env/bio/wildlife_crossings/)). Note, too, that in some studies, fencing has been shown to increase the rate of predation on prey that have been chased toward and trapped against fences by predators (e.g., Hartmann 2003, Little et al. 2002, Woods 1990).

Table 5: Fencing Attributes and Considerations.

<b>Functional Group</b>	<b>Height</b>	<b>Material</b>	<b>Additional Considerations</b>
Large mammals	8 – 12' (Clevenger and Waltho 2000, Putman et al. 2004, Cain et al. 2003)	Chain link (Singer and Doherty 1985, Foster and Humphrey 1995, Falk et al. 1978)	V-mesh difficult to climb may reduce maintenance costs. Should be buried if digging by coyotes likely to be a problem (Jacobson 2002). Remove trees, large bushes, etc. that could allow an animal to climb over fence. Fencing should extend on either side of the structure the entire length of the parcel boundary or just beyond a natural break in an animal's ability to traverse the landscape. Integrate one-way gates or escape ramps to prevent animals from being trapped in the right-of-way (Ford 1976).
Medium mammals	3 – 6' to prevent medium mammals from jumping or climbing over (Dodd et al. 2004, Taylor and Goldingay 2003)	Chain link (Taylor and Goldingay 2003) or wire with large gap beneath bottom strand if pronghorn passage desired.	To prevent animals from digging under fence, fencing should be buried several inches. Remove trees, large bushes, etc. that could allow an animal to climb over fence. In general, length of fencing should exceed an animal's ability to traverse the landscape and guide them to the crossing structure.
Small mammals	3 – 4' to prevent small animals from jumping or climbing over (Dodd et al. 2004)	Wire mesh (Lode 2000)	Many small mammals are fossorial; to prevent these animals from digging under fence, fencing should be buried several inches. Remove trees, large bushes, etc. that could allow an animal to climb over fence. In general, length of fencing should exceed an animal's ability to traverse the landscape and guide them to the crossing structure.
Terrestrial reptiles	1.5 – 2.5' with lipped wall or overhang to prevent animals from climbing or jumping over (Dodd et al. 2004, Puky 2003)	Impenetrable materials including galvanized tin, aluminum flashing, plastic, vinyl, concrete, or a very fine mesh.	Fencing should be buried to a depth of several inches to eliminate gaps that may be caused by animals digging. In general, length of fencing should exceed an animal's ability to traverse the landscape and guide them to the crossing structure. Some snakes and treefrogs have been observed climbing vegetation along fencing (Dodd et al. 2004), thus maintenance must include regular removal of vegetation near fencing.
Amphibians and aquatic reptiles	1.5 – 2.5' with lipped wall or overhang to prevent animals from climbing or jumping over (Dodd et al. 2004)	Impenetrable materials including galvanized tin, aluminum flashing, plastic, vinyl, concrete, very fine mesh.	Regular maintenance essential for use, as substrate has been shown to affect use by amphibians (Jackson in Evink et al. 1996). Some snakes and treefrogs have been observed climbing vegetation along fencing (Dodd et al. 2004), thus maintenance must include removal of vegetation near fencing.



## 4.2.5 Median Barriers

Median barriers are nearly ubiquitous across the landscape and are commonly employed to reduce vehicle/vehicle collisions. Perforated median barriers have been deployed to enable passage by small animals, but nearly nothing is known about their efficacy in facilitating wildlife passage, reducing wildlife mortality, or reducing wildlife/vehicle conflicts. Clevenger and Kociolek (2006) recently conducted a review of median barriers, including an exhaustive literature review; this report is essential reading for Caltrans wildlife crossing design staff. Clevenger and Kociolek (2006) note that: “there is a glaring lack of information about how the ubiquitous median barriers on our roadways impact wildlife. ....even the most basic or cursory guidelines to help transportation agencies when working on median barrier projects do not exist.” A good recent study showing the effectiveness of a barrier wall and culverts in reducing mortality of vertebrates in Florida is provided by Dodd et al. (2004), which found that the combination barrier wall/culvert system reduced mortality of vertebrates crossing a highway by 65-93% vs. pre-barrier conditions.



Figure 26: Median Barrier with gap. Caltrans photo.

Recently, Jersey-type and similar median barriers have been deployed with gaps between barrier segments (Figure 25) with the belief that the gaps between segments would permit safe passage of organisms that might otherwise be trapped on the road surface. However, the efficacy of median barriers with gaps has yet to be demonstrated in field situations (Clevenger and Kociolek 2006). Medians with “scuppers”, small, semi-circular openings designed to permit passage by small and medium-bodied mammals, have been deployed near San Luis Obispo, but their efficacy has yet to be demonstrated (Clevenger and Kociolek 2006).

## 4.2.6 Signs

Signs are used extensively to inform motorists of regions where the danger of wildlife collisions is high. However, despite their widespread use, the effectiveness of signs in reducing collisions has been incompletely studied and is not well known (Transportation Research Board 2002).

- Some work has suggested that signs may be generally ineffective at reducing vehicle collisions with ungulates (reviewed by Groot Bruinderink and Hazebroek, 1996) except in specific cases, such as during well-defined seasonal migrations (Sullivan et al. 2004)
- Sign effectiveness has been shown to decrease



Figure 27: Wildlife Warning Sign (derived from <http://www.betterroads.com>)

with time, and most studies suggest that to remain effective at reducing motorist speeds and reducing animal-vehicle collisions, signs ought to be used seasonally and/or temporarily (e.g., Sullivan et al. 2004)

- Signs with additional warning mechanisms such as flashing lights, or words deployed seasonally, may be relatively more effective, as many signs are ignored by motorists (Carr et al. 2003, Hardy et al. 2006; Figure 26).
- Signs may be especially appropriate in situations where other crossing measures are impractical, such as in marshy areas or where traffic volumes are low (Carr et al. 2003). In such situations, signs designed to reduce vehicular speed through known wildlife crossing areas may help to reduce rates of collision.

#### **4.2.7 Lighting**

Lighting, especially when used in conjunction with fencing and signage, has been shown to be effective in reducing collisions with large mammals (Reed and Woodard 1981, Maine DOT 2001) by increasing driver visibility and reaction time, especially at night when many large animals are most active (Reed and Woodard 1981), and by reducing animal crossing by those animals that avoid lighted areas. Conversely, lighting components of a project may be evaluated to reduce glare in areas important for wildlife crossing where safe passage is ensured.

The use of lighting is, however, often limited to areas with a nearby power source, but has generally been found to be a cost effective solution to vehicle-animal collisions, especially in urban and suburban regions with high collision rates.

#### **4.2.8 Reflectors**

Reflectors, typically round plastic devices deployed on top of posts that reflect the lights of on-coming traffic at night, have been used in attempts to prevent deer from entering highway rights-of-way, but these devices have generally been found ineffective (D'Angelo et al. 2007) and their use to enhance wildlife crossing is not encouraged.

#### **4.2.9 Speed Bumps**

Speed bumps may be used to reduce vehicle speed and potential for vehicle/animal conflict in local streets, especially where the existing speed limits are relatively low, visibility is limited by a curve in the road or adjacent concealing vegetation, and where surrounding habitat increases the risk of collision (Carr et al. 2003). This is probably not a plausible measure for most highway systems but has been used in some regions with high rates of animal-vehicle collisions to get drivers' attention by creating noise and help to get drivers to slow down.

#### **4.2.10 Vegetation**

Vegetation must be carefully considered when designing mitigation structures, as vegetation may enhance or reduce the effectiveness of crossing structures by attracting or repelling species of management interest. Whenever possible, it is preferable to use native plants, as these, although

potentially more costly at the outset, may save money in the long term due to lower maintenance requirements, better establishment, and suppression of weed species (White and Ernst 2003). Exotic invasive species pose a serious threat to native species of plants and animals, and as many invasive species are found in association with roadsides, the responses of plants to mitigation and maintenance activities needs to be documented. The Federal Highway Administration maintains a website with much useful information on roads and invasive species at: <http://www.tfhr.gov/pubrds/marapr00/invasiv1.htm>.

The design for many wildlife overpasses and underpasses includes the removal of vegetation from wide strips on both sides of the road near to the crossing to discourage animal use of the road while vegetation is left in an area leading to the overpass or underpass. This design is intended to encourage wildlife use the overpass or underpass and these efforts to direct animal movements are often reinforced by fencing.

#### **4.2.11 Animal Detection Systems – Advanced Technology**

Although primarily intended to reduce the frequency of vehicle/animal collisions, the utilization of emerging technologies seeks to provide a new method to enhance the crossing of highways by large-bodied mammals. The current state of the art technology was comprehensively reviewed in the recent (08/2006) report, “Animal Vehicle Crash Mitigation Using Advanced Technology” (available at [http://www.oregon.gov/ODOT/TD/TP\\_RES/docs/Reports/AnimalVehicle.pdf](http://www.oregon.gov/ODOT/TD/TP_RES/docs/Reports/AnimalVehicle.pdf)).

Two systems were chosen for evaluation. One system deployed in Yellowstone National Park, intended primarily for elk, the other in Pennsylvania intended primarily for deer.

The Yellowstone system consisted of a microwave signal “break-the-beam” system. While it performed well, it did not detect all of the elk that approached the road due to “blind spots” that may or may not be remedied in other installations. It also did not detect most medium and small sized mammals. This system was poorly accepted by motorists due to its intrusive design, and if deployed, especially in scenic areas, will need to be redesigned to “blend in” more with the surrounding landscape.

The Pennsylvania system was comprised of a microwave signal “area-coverage” system. It failed to detect humans as models for deer movement and was removed; thus, it contributes little to our knowledge of advanced systems for animal detection.

Further study of these and similar systems is needed before any conclusions can be reached regarding their effectiveness in reducing vehicle-animal conflicts.

#### **4.2.12 Escape Ramps/One-way Gates/Median Barrier Gaps**

Occasionally, despite the best prevention efforts, animals find their way on to roadways. It is essential to plan for such situations and to include escape ramps (Figure 24), one-way gates (e.g., Ford 1976 for deer underpasses in Lassen and Sierra Counties), gaps in median barriers (Figure 25), or similar structures to enable animals to get out of the right-of-way and to return to adjacent habitats.

## ***4.3 Modifying Existing Infrastructure to Enhance Wildlife Crossing***

In many cases, it may be possible to increase permeability, reconnect fragmented habitats, and increase public safety by modifying existing infrastructure. Such modifications may be possible for a fraction of the cost of providing new structures and may help to meet wildlife crossing goals.

### **4.3.1 Bridges and Overpasses**

The slopes beneath bridges and overpasses, even in suburban areas, are often used for movement between habitat patches by many species of wildlife. Bridges and overpasses, although not originally designed to facilitate animal movement, may be modified to permit safe passage by:

- modifying the slope beneath the bridge or overpass to allow easier movement
- providing a slope material that more closely matches surrounding natural substrates
- adding a bench or similar “wildlife path” to facilitate movement
- installing fencing to direct animals to the slope and to prevent their movement on to the road surface

An example is the Bocca/Floristan Upgrade and Bridge Replacement in Nevada County. Here, observations have confirmed use by deer of the slope under the bridge so a bench was provided above the rip-rap to enhance wildlife movement. Additional examples are provided on the wildlife crossing website ([http://www.dot.ca.gov/hq/env/bio/wildlife\\_crossings/](http://www.dot.ca.gov/hq/env/bio/wildlife_crossings/)).

### **4.3.2 Culverts**

In many cases, culverts have been installed to convey water under a roadway rather than to enhance wildlife movement; however, if existing culverts are large enough, they may allow safe passage of a variety of small and medium-bodied mammals from amphibians to coyotes (e.g., Yanes et al. 1995; Clevenger and Waltho 1999, Clevenger et al. 2001, Krawchuk et al. 2005, Ng et al. 2004, Taylor and Goldingay 2003). Providing appropriate substrate leading up to a culvert can enhance the possibility of its use: Figure 27 shows an example from San Bernardino County where small gravel was used to fill in the spaces in a rip-rap bed leading up to a series of culverts; these culverts were confirmed to allow passage of desert tortoises after the gravel was added. Adding ledges to culverts (Figure 22) has been shown to encourage many terrestrial species including coyotes, other small and medium-bodied mammals and reptiles to use culverts for crossing beneath roads. Maintenance of the entrances of culverts has been shown to greatly influence their rates of use (e.g., Yanes et al. 1995), as periods of high



*Figure 28: Culverts under I-15, San Bernardino County (Caltrans photo)*

precipitation can lead to scouring and “hanging culverts” which are inaccessible to animals. Culverts may also become clogged with sediment and may need to be cleaned periodically. Lastly, vegetation may grow up to obscure culvert entrances and must be maintained in an appropriate condition to ensure culvert use (Clevenger et al. 2001).

### 4.3.3 Median Barriers

Median barriers come in a variety of designs and materials and are used to enhance public safety by separating opposing lanes of traffic. However, median barriers also affect wildlife and these effects were comprehensively documented in a recent (October, 2006) Caltrans-supported report by Clevenger and Kociolek. Concrete “Jersey-style” barriers are the most common style in the U.S. and recently, “Jersey-style” median barriers with “scuppers”, or small openings on the bottom, have been installed with the intent of allowing passage beneath the barrier by smaller-bodied organisms; however, the efficacy of these openings in reducing mortality and increasing safe wildlife passage has yet to be demonstrated (Clevenger and Kociolek 2006). Jersey-style concrete barriers with gaps (Figure 25) may permit animals otherwise trapped on the right-of-way to escape and to pass safely across a road surface.



Figure 29: State Hwy. 163 median barrier.

Galvanized steel rails and cables are permeable to small and medium-sized vertebrates, but may impede highway crossing by large-bodied vertebrates (Clevenger and Kociolek 2006), and cables present risks to motorists. Because of the potential for trapping animals near traffic, separating young from their parents, and impeding or preventing passage of animals between habitats, median barriers often present wildlife crossing conflicts and modifications to original designs (e.g., scuppers, gaps, and one-way gates) may help to ameliorate some of these conflicts.

Table 6 summarizes some of the more common median barrier designs and ranks their potential for permeability to wildlife functional groups (after Clevenger and Kociolek 2006).



Table 6: Potential relative permeability of median barrier types to wildlife functional groups.

Median Barrier Type	Wildlife Functional Group				
	1	2	3	4	5
Concrete	Red	Red	Yellow	Green	Green
Ontario Tall Wall	Red	Red	Red	Red	Red
Concrete with gaps	Yellow	Yellow	Yellow	Green	Green
Concrete with scuppers	Yellow	Yellow	Yellow	Green	Green
Concrete with gaps and scuppers	Yellow	Yellow	Yellow	Green	Green
Metal beam	Green	Green	Green	Green	Green
Cable	Green	Green	Green	Green	Green
Centerline rumble strips	Green	Green	Green	Green	Green
Vegetated Median	Green	Green	Green	Green	Green
<b>Legend:</b> <b>Red:</b> no to low permeability, <b>yellow:</b> moderate permeability, <b>green:</b> high permeability. 1 = mice, shrews, salamanders, frogs, snakes; group 2 = rats, squirrels, weasels, turtles, young waterfowl, upland birds; group 3 = marten, fisher, mink, badger, skunk, fox, opossum; group 4 = coyote, bobcat, otter, raccoon; group 5 = bear, elk, deer, pronghorn, bighorn sheep, mountain lion.					

## 4.4 Choosing a Wildlife Crossing Improvement Measure

Potential strategies for improvements may include:

1. changing traffic patterns and trying to change driver behavior
2. modifying/controlling wildlife access to road-ways
3. providing infrastructure that allows wildlife passage over or under the roadway

### 4.4.1 Which Structure or Action?

In cases where the recommendation is to build structures specifically to enhance wildlife crossing, you will need to thoroughly justify your recommendation due to its cost. Your justification should be based upon effects, laws, regulations, and the ability of the recommendation to reduce effects. In some cases, retrofitting an existing bridge, underpass, or culvert will be less expensive than building a new structure and may be a viable alternative to new construction. Table 7 links structures to project goals and Table 8 links design specifications to focal animal groups; together they may help to justify a particular recommendation, but where possible it is best to cite a case study where your recommended action has had demonstrated benefits.

While controlling traffic speed is often the least expensive way to reduce rates of vehicle-wildlife collisions, improve driver safety, and protect wildlife, it is difficult to implement in many situations and may rely upon effective driver education. Where possible, traffic speeds may be reduced by:

1. reducing speed limits combined with enforcement
2. signs with or without accessories (flashing/blinking lights, warning messages)
3. signs and/or lights triggered by wildlife movement
4. rumble strips and other road-bed structures (e.g., Carr et al. 2003)

Controlling traffic speed through the use of signs may be the least effective of these alternatives, as several studies have shown that signs have little effect on driver behavior except immediately after installation (e.g., Ford 1976, Sullivan et al. 2004).

**Table 7:** Mitigation goals and wildlife size group-appropriate crossing structures.

		<b>Wildlife bridge / underpass</b>	<b>Large culverts</b>	<b>Small culvert or tunnel</b>	<b>Traffic calming &amp; education</b>
<b>Mitigation goals</b>	Retain/restore connectivity	X	X		X
	Reduce traffic accidents	X	X		X
	Connect habitats for protected species	X	X	X	
<b>Species size-group</b>	Small			X	X
	Medium	X	X		X
	Large	X	X		X

#### 4.4.2 How to Size a Structure

Generally, larger structures will provide greater opportunity for a larger number of wildlife species to safely cross over or under a roadway (Cavallaro et al. 2005; Clevenger and Waltho 2005). Vegetated overpasses (“wildlife bridges”) provide connectivity across a highway for the majority of mammals, terrestrial birds, and some reptiles. Similarly, wildlife underpasses provide safe crossing for a large number of vertebrates, although the openness ratio (see text box,

below) of the underpass must be large to ensure passage by deer and other large vertebrates (Ford 1976). Culverts with appropriate substrate provide connectivity to most small and medium-sized mammals, reptiles, amphibians, and occasionally some large mammals (Cavallaro et al. 2005). In all cases, the structure's openness ratio may be a critical consideration (see text box, below), as several studies have shown that the “tunnel effect”, i.e. the appearance of a tunnel rather than a movement corridor, diminishes the use of many structures (e.g., Ford 1976). Tables 7 and 8 and Section 3.4 summarize size considerations for wildlife structures.

#### **4.4.3 Adjacent Functions and Uses**

To make most effective use of crossing enhancement opportunities and actions, and to justify the expenditure of taxpayer dollars, it is essential to consider current and expected land uses and ownership surrounding the project area. In order to make mitigation actions more effective, they should be consistent with local planning regulations. CEQA and NEPA require Environmental Impact documents (EIRs and EISs) to document that feasible alternatives and mitigation measures are consistent with local land uses, planning documents, and regulations. In addition to the planning documents, these functions and uses may be known from knowledge of the area, or discovered through simple mapping of the area of concern. Facilitated crossing using structures or focused traffic calming should be connected to natural or semi-natural corridors that provide conduits to larger areas of natural habitat.

#### **4.4.4 Spacing of Structures**

The spacing of structures scales with animal size: smaller species require smaller but more closely-spaced structures with smaller openness ratios while larger species require larger, more widely-spaced structures (Clevenger and Waltho 2005) with larger openness ratios. Accommodating a diversity of species requires a diversity of crossing structures (e.g., over and under-passes, pipe and box culverts; Clevenger and Waltho 2005). While some studies have found that crossing *location* is the most important determinant of use (Yanes et al. 1995; Ng et al. 2004), others have emphasized structure *design* as being more important (Cain et al. 2003). A crossing plan should consider both local and regional wildlife movement needs, and take both habitat characteristics and focal species group into consideration (Clevenger and Waltho 2005) to benefit the largest number of species. Spacing of crossing location improvements may also depend on the topography and the appropriate site locations for improvements. Spacing of structures should help accomplish the goals you have considered to address the effects associated with your project and the context of your location.

### ***4.5 Design Specifications***

There are currently no standard design specifications for wildlife crossing structures adopted by the Department; however there are several examples of structures that have been utilized for different species and environmental circumstances. Since crossing locations can be expected to differ substantially from one another in terms of topography, facility type, focal species, grade, and other considerations, design specifications must be location, species, and goal-appropriate. The most appropriate design specification in any given situation will result from coordination

with your PDT, knowledge of what has worked elsewhere in similar circumstances, and consultations with local experts. Table 8 summarizes the preferred design specifications for the three functional species groups.

In general, the sizes of the animals in the focal group correlate directly with the size of the most appropriate crossing structure, e.g., large-bodied animals require large, open crossing structures, medium-sized animals will utilize both the larger structures required by larger animals as well as smaller culverts, and small-bodied animals will utilize the smallest culverts but terrestrial forms require ledges or other dry substrate if the culvert is installed in a drainage. Small animals may perceive the largest crossing structures as appropriate habitat and live permanently thereon (Clevenger and Waltho 2005).

The USDA Forest Service has a Website with a small library of design drawings for constructed crossings ([http://www.fs.fed.us/rm/RRR/Technologies/Wildlife\\_Crossings.html](http://www.fs.fed.us/rm/RRR/Technologies/Wildlife_Crossings.html)). The “Wildlife Crossing Toolkit” also has some useful descriptive drawings (<http://www.wildlifecrossings.info/summary.htm>). Additional design specifications are available in recent reports from work in Ventura County (Cavallaro et al. 2005) and are reviewed comprehensively by Forman and Alexander (1998). Some case studies of crossing improvements have also been identified on FHWA’s “Keeping it Simple” website at <http://www.fhwa.dot.gov/environment/wildlifeprotection/>.

Table 8: Preferred design specifications appropriate for functional species groups.

Species Group	Preferred Design Specifications
Large mammals (deer, elk, bear, mountain lion)	large, open crossing structures with an openness ratio of at least 0.75, are easily accessible, and incorporate fencing (“funneling”) to direct animals to the crossing structures and to prevent animals from entering the highway (Cavallaro et al. 2005); one-way gates or escape ramps must be incorporated to enable trapped animals to escape. Clear visibility through to vegetation at the other end of the crossing essential.
Medium-sized mammals (fox, coyote, skunk, rabbit, raccoon, opossum)	box or pipe culverts (Clevenger et al. 2003) that are at least 3’ high, have an openness ratio of at least 0.4, are easily accessible, incorporate funneling to prevent animals from entering the highway and direct them to the crossing structure (Cavallaro et al. 2005). Clear visibility through to vegetation at the other end of the crossing essential. Ledges needed in modified, existing culverts for drainage.
Small mammals (squirrels, rats, voles, mice), reptiles, and amphibians	a mix of small pipes, box culverts, and pipe culverts that are 1’ or more high, provide natural vegetation of low stature near the openings to provide cover, are easily accessible, and incorporate funneling to prevent animals from entering the highway and to direct them to the crossing structure (Cavallaro et al. 2005). Should be closely spaced to accommodate movements of small bodied animals.

## 4.6 Identify Maintenance Needs

Existing and newly-installed wildlife crossing structures must be periodically maintained to continue to provide safe passage as, in the absence of routine maintenance, these structures may be avoided or become unusable by the species that they were intended to benefit (e.g., Dodd

2004). Although crossing structures may become ineffective without post-project monitoring and maintenance, reliable funding has been a historical problem. As shown in the decision trees (Figures 2 and 3), it is essential to identify the requirements for monitoring (see also Section 3.8) and to monitor and maintain the crossing site and to ensure that long-term maintenance resources are provided in the project budget.

Maintenance staff should be involved in the wildlife crossings planning to provide input on design considerations and their effects on maintenance needs as well as in post-project assessments to consult on any maintenance concerns that may have arisen. It cannot be assumed that crossing structures, once in place, will remain effective without periodic maintenance, and maintenance crews must be informed of the procedures necessary to keep crossing structures accessible and to function as intended.

Maintenance activities may include:

- clearing of vegetation and maintenance of aprons of culverts. If scouring following storms prevents access, the scoured rocks or soil should be replaced with like materials to eliminate “hanging culverts” and not replaced with boulders, rip-rap or other substrates unsuited to the animal species the culvert was intended to benefit
- fences should be cleared of accumulated debris and repaired if they are torn or displaced from their original positions
- vegetated over and under-crossings should be kept free of weeds that inhibit passage of all but the largest animals while native plants are encouraged to provide cover or forage

## 4.7 Costs

The costs associated with mitigating wildlife/vehicle conflicts can be substantial and these costs increase through time. The materials costs of several types of structures for enhancing wildlife passage for a variety of mammals are estimated in Table 9 and were derived from the 2003 Caltrans Contract Cost Data book, available at:

<http://www.dot.ca.gov/hq/esc/oe/awards/2003CCDB/2003ccdb.pdf>.

Table 9: Crossing Structure Materials Costs

<b>Crossing Structure Type</b>	<b>Approximate Range of Cost(s)</b>
Box culvert, Class 1 concrete	\$565-\$1,380/cubic meter
Box culvert, Class 2 concrete	\$620-\$3,630/cubic meter
12” alternative pipe culvert	\$113/linear foot
18” alternative pipe culvert	\$192/linear foot
1050 mm alternative pipe culvert	\$1,250/meter

These costs are variable depending upon site and application-specific characteristics, and include material costs alone; installation and maintenance costs are additional. It is suggested that collaboration with your design engineer and project manager are essential in understanding the design and costs associated with proposed structural improvements or installation. Caltrans intends to compile cost data on a per project basis as projects are undertaken and to post available data on the website ([http://www.dot.ca.gov/hq/env/bio/wildlife\\_crossings/](http://www.dot.ca.gov/hq/env/bio/wildlife_crossings/)) that accompanies this manual.

## ***4.8 Post-project Monitoring and Adaptive Management***

It is essential to incorporate post-project monitoring and adaptive management into project planning and to assess the effectiveness of mitigation measures (Clevenger 2005; Dodd et al. 2004). Such monitoring and assessment actions are of great benefit to local, regional, and statewide transportation professionals, as knowledge of what does and does not work in particular circumstances will lead to better mitigation outcomes and save time, effort, and money. Projects should be monitored for several years, as field research has shown that there may be a lag period after project completion and effects on species populations (Findlay and Houlahan 1997, Findlay and Bourdages 2000). Long-term, post-project monitoring is also essential to accurately assess the results of installing crossing enhancements, as in many cases there is a period, often lasting up to 3 years for large-bodied mammals, of "structure shyness", that is, an active avoidance of new structures by the very animals that they are designed to benefit (Clevenger and Waltho 2003, Wildlife Crossings Toolkit 2003, Hardy et al. 2003; Huijser et al. 2006). Post-project assessments help to inform not only Caltrans, but also an international audience of biologists, planners, and engineers of effective design types and actions (Carr et al. 2003) and case study examples should be entered into the wildlife crossing website ([http://www.dot.ca.gov/hq/env/bio/wildlife\\_crossings/](http://www.dot.ca.gov/hq/env/bio/wildlife_crossings/)). The best projects will incorporate both pre-project assessments and post-project monitoring, to quantify and document mitigation effectiveness (e.g., Trombulak and Frissell 2000; Dodd et al. 2004).

Similarly, if post-project monitoring suggests that modifications to the original design will result in greater use, these modifications should be implemented, documented, and made widely known to Caltrans staff. For example, if an original project plan called for the installation of a culvert with associated fencing but the fencing was subsequently found to be inappropriate or ineffective, modified, and the modified design was shown to be more effective, this provides a valuable example of adaptive management. Such adaptive management actions may be especially helpful to improve mitigation performance elsewhere, and the results of such actions should be widely disseminated among Department staff, including by entering a case study record into the wildlife crossing website.

### *Mitigation Effectiveness Criteria*

- Comparison of pre- to post-project total number of crossings
- Comparison of pre- to post-project crossing rates for target species
- Comparison of pre- to post-project repel rates
- Comparison of pre- to post-project rates of percentage use
- Ratio of observed to predicted use of structures
- Post-project reduction in number of animal-vehicle collisions

P. Cramer, 2007; personal communication

Coordination with regulatory agencies is an essential component of monitoring and reporting requirements and may require partnering with adjacent landowners or land managers.

A range of options to assess project effectiveness has been described, but few projects have incorporated both pre-project assessments and post-project monitoring; three projects illustrate excellent design:

1. The SR 23 widening project in Ventura County utilized information from the Ng et al. (2004) study of mountain lion crossings in Southern California, which used a combination of remotely triggered cameras and gypsum track stations to monitor three culverts prior to, during, and after construction. This on-going study will evaluate of the effectiveness of mitigation and maintenance measures (improved fencing, culvert cleaning); thus, this project represents a good template for similar projects because of the thoroughness of the pre- and post-project monitoring and assessment (Sikich and Riley, 2007).
2. An assessment of a barrier wall and culvert project in Paynes Prairie State Preserve, Florida (Dodd et al. 2004) calculated rates of mortality along a busy highway for one year prior to project construction and compared these to the rates one year after the barrier wall and culverts were installed to quantitatively assess the effectiveness of the barrier wall and culvert system at reducing mortality rates.
3. Clevenger and Waltho (2005) studied primarily large-bodied mammals (carnivores and their prey) in Banff National Park, Canada and found that species' response to crossing structures was not uniform but was instead species-specific, and concluded that where the goal is to benefit a diverse array of species, a similarly diverse array (sizes, types) of crossing structures is needed.

Hardy et al. (2003) provide a generalized overview of the methodological issues involved in evaluating the effectiveness of mitigation strategies. According to the Hardy et al. (2003) approach, the seven steps to plan an effective evaluation effort are to:

1. Identify evaluation questions and definitions of effectiveness
2. Identify effectiveness criteria (see text box, above)
3. Design monitoring program
4. Pilot methods, adjust to meet goals, project budgets
5. Collect data for evaluation
6. Analyze data to determine effectiveness
7. Report results

It is also essential to document and report negative results, that is, findings that a project was not effective at meeting its objectives, and to try to understand the factors responsible for the lack of effectiveness. Documenting and disseminating the results of actions allows all to gain from local experience, and knowledge gained from one project may serve to increase the likelihood of success in the future.





## 5 Keeping Informed

The field of road ecology is advancing rapidly, with results of research and mitigation actions being published at ever-increasing rates. Similarly, new materials and techniques are being developed and field-tested which may provide a greater range of opportunities for enhancing wildlife crossing while protecting public safety. Thus, it is essential for Department staff to keep informed of new developments, and the following section provides a guide to primarily web-based resources that are updated continually and have been found to be particularly useful.

### 5.1 Internet Resources

The science of road ecology is new and developing rapidly. The internet may serve as the best resource to enable Caltrans staff to stay abreast of research and developments. Below is provided a listing of some of the internet resources that may be especially helpful.

#### 5.1.1 Caltrans Resources

- Caltrans Standard Environmental Reference (SER), Chapter 14, Biological Resources, <http://www.dot.ca.gov/ser/vol1/sec3/natural/Ch14Bio/ch14bio.htm#14decisiontree>.
- EnviroNet (Caltrans intranet site) – [http://pd.dot.ca.gov/env/bio/html/wildlife/crossing\\_index.htm](http://pd.dot.ca.gov/env/bio/html/wildlife/crossing_index.htm)
- Caltrans Intranet “Connectivity and Crossings” webpage [http://pd.dot.ca.gov/env/bio/html/wildlife/crossing\\_index.htm](http://pd.dot.ca.gov/env/bio/html/wildlife/crossing_index.htm)
- Caltrans Wildlife Crossings Collaboration Website. The Caltrans-supported website, [http://www.dot.ca.gov/hq/env/bio/wildlife\\_crossings/](http://www.dot.ca.gov/hq/env/bio/wildlife_crossings/), provides a continuously updated and searchable electronic version of this manual, including a searchable bibliography, plus additional resources such as case studies and process decision trees.

#### 5.1.2 Federal Highway Administration Resources

- Federal Highway Administration (FHWA)
  - Keeping It Simple, part of the Critter Crossings Web site (<http://www.fhwa.dot.gov/environment/wildlifeprotection/index.cfm>)
  - federal wildlife legislation affecting transportation ([http://www.fhwa.dot.gov/environment/env\\_sum.htm](http://www.fhwa.dot.gov/environment/env_sum.htm))

#### 5.1.3 Academic Institution Resources

- U.C. Davis Road Ecology Center
  - the Road Ecology Center (<http://roadecology.ucdavis.edu/>) at the University of California, Davis has many resources, including scientific reports and upcoming workshop announcements
- The Wildlife, Fisheries, and Transportation Research Database hosted by the Center for

Transportation and the Environment at North Carolina State University in Raleigh (<http://www.itre.ncsu.edu/CTE/gateway/wildlife.htm>)

- contains links to primary literature, agency reports, and ICOET proceedings and is searchable by several criteria

#### **5.1.4 International Conference on Ecology and Transportation (ICOET)**

- The ICOET website (<http://www.icoet.net/>) contains announcements and links to PDF files to all conference proceedings

#### **5.1.5 Other Wildlife Crossings-related Websites**

- Wildlife and Roads Web Site
  - the Wildlife and Roads web site (<http://www.wildlifeandroads.org/>) is specifically oriented toward the evaluation of the use and effectiveness of wildlife crossings and should be consulted for additional information, current literature, and research results
- The Infra Eco Network Europe web site (<http://www.iene.info/>)
  - contains announcements, member information, and a database searchable by literature, measures (mitigation types), metadata, or projects
  - primarily European focus
- The deercrash.com web site (<http://deercrash.com/>) of the Deer-Vehicle Crash Clearinghouse at the Texas Transportation Institute
  - contains announcements and information for those interested in mitigating deer-vehicle conflicts
- The American Association of State Highway and Transportation Officials Center for Environmental Excellence web site (<http://environment.transportation.org/>)
  - site provides much current information, announcements, compliance guides, and even a technical assistance program
  - developed in cooperation with the Federal Highway Administration
- Wildlife Crossings Toolkit, USDA Forest Service (<http://www.wildlifecrossings.info/>)
- Wildlife crossing and structures, Defenders of Wildlife (<http://www.defenders.org/wildlife/flbears/wildlifecrossing.html>)
- Wildlife crossings – design and placement, USDA Forest Service ([http://www.fs.fed.us/rm/RRR/Technologies/Wildlife\\_Crossings.html](http://www.fs.fed.us/rm/RRR/Technologies/Wildlife_Crossings.html))
- Wildlife crossing guidebook for municipal planners, Portland Oregon (<http://www.metro-region.org/article.cfm?articleid=15005>)
- Wild animals and roads, Humane Society of the United States ([http://www.hsus.org/wildlife/issues\\_facing\\_wildlife/wildlife\\_crossings\\_wild\\_animals\\_and\\_roads/](http://www.hsus.org/wildlife/issues_facing_wildlife/wildlife_crossings_wild_animals_and_roads/))

## ***5.2 Additional Information on Wildlife Survey Methods***

There are many sources of additional information on field survey methods; some of the most useful include:

- The Caltrans Standard Environmental Reference, Volume 3 Biological Resources, Chapter 2 – Natural Environment Study, Section 2-4.4 cites 6 standard references (Brookhout, T. A. Editor. 1994; Cooperrider et al., Editors, 1986; Davis 1990; Hays et al. 1981; Leedy and Adams 1982; and Ralph et al. 1993) published by agencies or professional associations; each of these provides sufficient detail to enable any competent biologist to employ a field method with which he or she may not have previously been familiar.
- The California Department of Fish & Game Web site provides basic survey and monitoring protocols and guidelines ([http://www.dfg.ca.gov/hcpb/species/stds\\_gdl/survmonitr.shtml](http://www.dfg.ca.gov/hcpb/species/stds_gdl/survmonitr.shtml))
- The Wildlife Crossings Toolkit developed by the USDA Forest Service is designed for wildlife biologists and highway engineers and provides many useful case histories in a database format (<http://www.wildlifecrossings.info/beta2.htm>)
- *Measuring and Monitoring Biological Diversity: Standard Methods for Amphibians.* 1994. Edited by Heyer et al. A superb overview of field methods for amphibians but with much relevance to reptiles.
- *Measuring and Monitoring Biological Diversity: Standard Methods for Mammals.* 1996. Edited by Wilson et al. Excellent reference providing thorough reviews of field methods appropriate for all mammal groups.
- *Ecological Census Techniques*, a text edited by Wm. J. Sutherland (1996, 2006), provides instructions for conducting ecological censuses for a variety of organisms and is written for specialists and non-specialists alike.
- Pollock et al. (2002) provide a thorough review of statistical methods for design and analysis of large-scale monitoring of wildlife, but is intended for a sophisticated audience most interested in experimental design and proper statistical analyses

## ***5.3 Additional Mitigation Design Information***

The following are recent reports that, although not updated, provide excellent coverage of wildlife crossings issues as well as numerous illustrations and photographs depicting specific case studies and real-world implementations of crossing structures.

- “Designing Road Crossings for Safe Wildlife Passage: Ventura County Guidelines” available at: [http://www.bren.ucsb.edu/research/documents/corridors\\_final.pdf](http://www.bren.ucsb.edu/research/documents/corridors_final.pdf).
- “Wildlife Crossings: Rethinking Road Design to Improve Safety and Reconnect Habitat”, describes an extensive effort in the Portland, Oregon region; available at: <http://www.metro-region.org/article.cfm?ArticleID=15005>
- “Doing the Right Thing: Improving Transportation and Enhancing Ecosystems, Exemplary Ecosystem Initiatives” found on the Federal Highway Administration web

site at <http://www.fhwa.dot.gov/environment/ecosystems/index.htm> has many excellent examples of wildlife crossing mitigation measures from 2002-2005 from sites across the country

## ***5.4 Recommended Reading***

There are two books which are extremely valuable introductions and summaries of wildlife crossings and road ecology and that come as close as any to be “essential reading” for Caltrans biologists:

- Road Ecology: Science and Solutions (Forman et al., Island Press, 2003), and
- Corridor Ecology (Hilty, Lidicker, and Merenlander, Island Press, 2006).

Both texts provide excellent introductions that examine the many interactions between roads and wildlife. For an excellent overview article on roads and their ecological effects, see:

- Forman, R.T.T. and L.E. Alexander. 1998. Roads and their major ecological effects. *Ann. Rev. Ecol. Syst.* 29: 207-231.

## 6 Literature Cited

- Aresco, M.J. 2005. Mitigation measures to reduce highway mortality of turtles and other herpetofauna at a north Florida lake. *J. Wildl. Manage.* 69: 549-560.
- Barry, S.J. and H.B. Shaffer. 1994. The status of the California Tiger Salamander (*Ambystoma californiense*) at Lagunita: A 50-year update. *J. Herpetology* 28: 159-164.
- Bass, R.E., A.I. Herson, and K.M. Bogdan. 1999. CEQA Deskbook. Second Edition. Point Arena: Solano Press Books.
- Beier, P. and S. Loe. 1992. A checklist for evaluating impacts to wildlife movement corridor. *Wildl. Soc. Bull.* 20: 434-440; PDF available at: [http://oak.ucc.nau.edu/pb1/vitae/Beier-Loe\\_1992.pdf](http://oak.ucc.nau.edu/pb1/vitae/Beier-Loe_1992.pdf)
- Bennett, A.F. 2003. Linkages in the landscape: The role of corridors and connectivity in wildlife conservation. IUCN Forest Conservation Programme: Conserving Forest Ecosystems. Series 1. Available as pdf at: <http://app.iucn.org/dbtw-wpd/edocs/FR-021.pdf>
- Boarman, W.I., M. Sazaki, and W.B. Jennings. 1997. The effect of roads, barrier fences, and culverts on desert tortoise populations in California, USA. *Proc.: Conservation, Restoration, and Management of Tortoises and Turtles – An International Conference*, pp. 54-58.
- Brookhout, T. A., Editor. 1994. Research and management techniques for wildlife and habitats. The Wildlife Society, Bethesda, MD. 740 pp.
- Brown, V., H.G. Weston, and J. Buzzell. 1986. Handbook of California Birds, Third Edition. Naturegraph Publishers. 224 pp.
- Bull E. L., R. S. Holthausen, L. R. Bright. 1992. Comparison of three techniques to monitor marten. *Wildl. Soc. Bull.* 20: 406 – 410.
- Cain, A.T., V.R. Tuovila, D.G. Hewitt, and M.E. Tewes. 2003. Effects of a highway and mitigation projects on bobcats in Southern Texas. *Biol. Cons.* 114: 189-197.
- Caro, T. M., Shargel, J. A. and Stoner, C. J., 2000. Frequency of medium-sized mammal road kills in an agricultural landscape in California. *American Midland Naturalist* 144: 362-369.
- Carr, L.W. and L. Fahrig. 2001. Effect of road traffic on two amphibian species of differing vagility. *Cons. Biol.* 15: 1071-1078.
- Carr, T., R. Dacanay, K. Drake, C. Everson, A. Sperry, and K. Sullivan. 2003. Wildlife Crossings: Rethinking Road Design to Improve Safety and Reconnect Habitat. Portland Oregon, Metro.
- Case, R.M. 1978. Interstate highway road-killed animals: A data source for biologists. *Wildlife Society Bulletin* 6: 8-13.

- Cavallaro, L, K. Sanden, J. Schellhase, and M. Tanaka. 2005. Designing Road Crossings for Safe Wildlife Passage: Ventura County Guidelines. MS Thesis, U.C. Santa Barbara.
- Clarke, G.P., P.C.L. White, and S. Harris. 1998. Effects of roads on badger *Meles meles* populations in southwest England. *Biol. Cons.* 86: 117-124.
- Clevenger, A.P. 2005. Conservation value of wildlife crossings: measures of performance and research directions. *GAIA – Ecol. Perspect. For Sci. Tech.* 14: 124-129.
- Clevenger, A.P., B. Chruszcz, and K. Gunson. 2001. Drainage culverts as habitat linkages and factors affecting passage by mammals. *J. Appl. Ecol.* 38: 1340-1349.
- Clevenger, A.P., B. Chruszcz, and K. Gunson. 2003. Spatial patterns and factors influencing small vertebrate fauna road-kill aggregations. *Biol. Cons.* 109: 15-26.
- Clevenger, A.P. and A.V. Kociolek. 2006. *Highway median impacts on wildlife movement and mortality: State of the practice survey and gap analysis*. Prepared for the California Department of Transportation, Sacramento, California. Available at: [http://www.dot.ca.gov/newtech/researchreports/reports/2006/median\\_barrier\\_final\\_report.pdf](http://www.dot.ca.gov/newtech/researchreports/reports/2006/median_barrier_final_report.pdf)
- Clevenger, A.P., J. Wierzchowski, B. Chruszcz, and K. Gunson. 2002. GIS-generated expert-based model for identifying wildlife habitat linkages and planning mitigation passages. *Cons. Biol.* 16: 503-514.
- Clevenger, A.P. and N. Waltho. 2005. Performance indices to identify attributes of highway crossing structures facilitating movement of large mammals. *Biol. Cons.* 121: 453-464.
- Cochran, W.G. 1977. Sampling techniques. Third edition. New York, NY: John Wiley & Sons.
- Cooperrider, A. Y., R. J. Boyd, and H. R. Stuart, Editors. 1986. Inventory and Monitoring of Wildlife Habitat. U.S. Department of Interior, Bureau of Land Management, Service Center. Denver, CO., 858 pp.
- Craighead, A.C., E.A. Roberts, and F.L. Craighead. 2001. Bozeman Pass Wildlife Linkage and Highway Safety Study. International Conference on Ecology and Transportation, Keystone, Colorado, September, 2001.
- Cypher, B.L., G.D. Warrick, M.R.M. Otten, T.P. O'Farrell, W.H. Berry, C.E. Harris, T.T. Kato, P.M. McCue, J.H. Scrivner, and B.W. Zoellick. 2000. Population dynamics of San Joaquin Kit Foxes at the Naval Petroleum Reserves in California. *Wildlife Monogr.* 145.
- D'Angelo, G.J., R.J. Warren, K.V. Miller, G.R. Gallagher, and S.A. Valitzski. 2007. Final Project Report: Development and evaluation of devices designed to minimize deer-vehicle collisions. Available from the Transportation Research Board website ([http://gulliver.trb.org/news/blurb\\_detail.asp?id=7947](http://gulliver.trb.org/news/blurb_detail.asp?id=7947))
- Davis, D. E. 1990. CRC Handbook of Census Methods for Terrestrial Vertebrates. CRC Press. 375 pp.

- Dodd, C.K., W.J. Barichivich, and L.L. Smith. 2004. Effectiveness of a barrier wall and culverts in reducing wildlife mortality on a heavily traveled highway in Florida. *Biol. Cons.* 118: 619-631.
- Drennan, J.E., P. Beier, and N.L. Dodd. 1998. Use of track stations to index abundance of sciurids. *J. Mammal.* 79(1): 352-359.
- Dreschel, T.W., R.B. Smith, and D.R. Breininger. 1990. Florida scrub-jay mortality on roadsides. *Florida Field Naturalist* 18: 82-83.
- Elzinga, C.L., D.W. Salzer, J.W. Willoughby, and J.P. Gibbs. 2001. *Monitoring Plant and Animal Populations*. Malden, Mass., Blackwell Science.
- Erritzoe, J., T.D. Mazgajski, and L. Rejt. 2003. Bird casualties on European roads – a review. *Acta Ornithologica* 38: 77-93.
- Evink, G.L. 1990. Wildlife Crossings of Florida I-75. pages 54-59 in: *Transportation Research Record 1279*, Transportation Research Board, National Research Council, Washington, D.C.
- Evink, G.L., P. Garrett, D. Zeigler and J. Berry. 1996. (eds.). *Trends in Addressing Transportation Related Wildlife Mortality*, proceedings of the transportation related wildlife mortality seminar. State of Florida Department of Transportation, Tallahassee, FL. FL-ER-58-96.
- Falk, N.W., H.B. Graves, and E.D. Bellis. 1978. Highway right-of-way fences as deer deterrents. *J. Wildl. Manage.* 42: 646-650.
- Feldhamer, G.A., J.E. Gates, D.M. Harman, A.J. Loranger, and K.R. Dixon. 1986. Effects of interstate highway fencing on white-tailed deer activity. *J. Wildl. Manage.* 50: 497-503.
- Ford, S.G. 1976. Evaluation of highway deer kill mitigation on SIE/LAS-395: interim report. Federal Highway Administration report number FHWA/CA/TP-80/01.
- Forman, R.T.T. and L.E. Alexander. 1998. Roads and their major ecological effects. *Ann. Rev. Ecol. Syst.* 29: 207-231.
- Forman, R.T.T., B. Reineking, and A.M. Hersperger. 2002. Road Traffic and Nearby Grassland Bird Patterns in a Suburbanizing Landscape. *Environmental Management* 29 : 782-800.
- Forman, R.T.T, D. Sperling, J. A. Bissonette, A.P. Clevenger, C.D. Cutshall, V.H. Dale, L. Fahrig, R.L. France, C.R. Goldman, K. Heanue, J. Jones, F. Swanson, T. Turrentine, and T.C. Winter. 2003. *Road Ecology: Science and Solutions*. Washington, D.C.: Island Press.
- Foster, M. L. and S. R. Humphrey. 1995. Use of highway underpasses by Florida panthers and other wildlife. *Wildlife Society Bulletin* 23(1): 95-100.
- Frank, K., K.T. von Toschanowitz, and S. Kramer-Schadt.. 2005. Modeling roads and wildlife populations – two examples for the contribution of modeling to landscape fragmentation research. *Gaia – Ecological Perspectives for Science and Society* 14: 107-112.

- Germano, D.J. and R.B. Bury. 2001. Western pond turtles (*Clemmys marmorata*) in the Central Valley of California: Status and population structure. *Trans. West. Sec. Wildl. Soc.* 37: 22-36.
- Gibbs, J.P. 1998. Amphibian movements in response to forest edges, roads, and streambeds in southern New England. *J. Wildl. Manage.* 62: 584-589.
- Gibbs, J.P. and W.G. Shriver. 2002. Estimating the effects of road mortality on turtle populations. *Cons. Biol.* 16: 1647-1652.
- Gibbs, J.P. and W.G. Shriver. 2005. Can road mortality limit populations of pool-breeding amphibians. *Wetlands Ecology and Management* 13: 281-289.
- Gontier, M., B. Balfors, and U. Mörtberg. 2006. Biodiversity in environmental assessment – current practice and tools for prediction. *Env. Impact Assessment Rev.* 26: 268-286.
- Groot Bruinderink, G.W.T.A. and E. Hazebroek. 1996. Ungulate traffic collisions in Europe. *Cons. Biol.* 10: 1059-1067.
- Gutierrez-Espeleta, G.A., S.T. Kalinowski, W.M. Boyce, and P.W. Hedrick. 2000. Genetic variation and population structure in desert bighorn sheep: implications for conservation. *Conservation Genetics* 1: 3-15.
- Hardy, A., A. Clevenger, M. Huijser, and G. Neale. 2003. An overview of methods and approaches for evaluating the effectiveness of wildlife crossing structures: emphasizing the science in applied science. *Proceedings of the International Conference on Ecology and Transportation, Lake Placid, New York, August 24-29, 2003.*
- Hardy, A.A., S. Lee, and A.F. Al-Kaisy. 2006. Effectiveness of animal advisory messages on dynamic message signs as a speed reduction tool: A case study in rural Montana. *Trans. Res. Board Annual Meeting*
- Hartmann, M. 2003. Evaluation of wildlife crossing structures: their use and effectiveness. *Wildlands CPR website (<http://www.wildlandscpr.org/>)*. Site accessed September 2007.
- Hatch, S. A. 2003. Statistical power for detecting trends with applications to seabird monitoring. *Biological Conservation* 111:317-329.
- Hays, R. L., C. Summers, and W. Seitz. 1981. *Estimating Wildlife Habitat Variables*. FWS Report FWS/OBS-81/47. 111 pp.
- Heyer W.R., M.A. Donnelly, R.W. McDiarmid, L.C. Hayek, and M.S. Foster. 1994. *Measuring and Monitoring Biological Diversity: Standard Methods for Amphibians*. Smithsonian Institute Press, Washington, D.C., U.S.A.
- Hilty, J.A., W.Z. Lidicker, and A. Merenlender, Eds. 2006. *Corridor Ecology: The Science and Practice of Linking Landscapes for Biodiversity Conservation*. Washington, D.C.: Island Press.



- Hilty, J.A. and A.M. Merenlander. 2000. A comparison of covered track-plates and remotely-triggered cameras. *Trans. West. Sec. Wildl. Soc.* 29: 27-31.
- Huijser, M.P., P.T. McGowen, W. Camel, A. Hardy, P. Wright, A.P. Clevenger, L. Salsman, and T. Wilson. 2006. Animal vehicle crash mitigation using advanced technology. Phase I: Review, design and implementation. Salem, OR: Oregon Department of Transportation. Available at: [http://www.oregon.gov/ODOT/TD/TP\\_RES/docs/Reports/AnimalVehicle.pdf](http://www.oregon.gov/ODOT/TD/TP_RES/docs/Reports/AnimalVehicle.pdf).
- Jacobson, S. 2002. Using wildlife behavioral traits to design effective crossing structures. *Wildlife Crossings Toolkit*, U.S. Department of Agriculture, Forest Service.
- Jameson, E.W., Jr. and H.J. Peeters. 2004. *Mammals of California*, Second Edition. University of California Press. 440 pp.
- Krausman, P.R., V.C. Bleich, J.W. Cain III, T.R. Stephenson, D.W. DeYoung, P.W. McGrath, P. K. Swift, B.M. Pierce, and Brian D. Jansen. 2004. Neck lesions in ungulates from collars incorporating satellite technology. *Wildl. Soc. Bull.* 32: 987-991.
- Krawchuk, A., K.W. Larsen, R.D. Weir, and H. Davis. 2005. Passage through a small drainage culvert by mule deer, *Odocoileus hemionus*, and other mammals. *Can. Field-Nat.* 119: 296-298.
- Langton, A.E.S. 2002. Measures to protect amphibians and reptiles from road traffic. Chap. 20 in: *Wildlife and Roads: The Ecological Impact*. B. Sherwood, D. Cutler, and J.A. Burton, Eds. London: Imperial College Press.
- Leedy, D. L. and L. W. Adams. 1982. *Wildlife Considerations in Planning and Managing Highway Corridors*. FHWA Report. FHWA-TS-82-212. 93 pp.
- Little, S.J., R.G. Harcourt, and A.P. Clevenger. 2002. Do wildlife passages act as prey traps? *Biol. Cons.* 107: 135-145.
- Lodé, T. 2000. Effect of a motorway on mortality and isolation of wildlife populations. *Ambio* 29: 163-166.
- Loos, G. and P. Kerlinger. 1993. Road mortality of saw-whet and screech-owls on the Cape May Peninsula. *J. Raptor Research* 27: 210-213.
- Mace, R.D., S.C. Minta, T.L. Manley, and K.E. Aune. 1994. Estimating grizzly bear population size using camera sightings. *Wildl. Soc. Bull.* 22: 74-83.
- Maine Dept. of Transportation. 2001. Collisions between large wildlife species and motor vehicles in Maine, Interim Report. Maine DOT, April 2001. available at: <http://www.maine.gov/mdot/safety-programs/pdf/> (site accessed 03/29/2007)
- Malo, J.E., F. Suárez, and A. Díez. 2004. Can we mitigate animal-vehicle accidents using predictive models? *J. Appl. Ecol.* 41: 701-710.

- Marsh, D.M., G.S. Milam, N.P. Gorham, and N.G. Beckman. 2005. Forest Roads as Partial Barriers to Terrestrial Salamander Movement. *Cons. Biol.* 19: 2004-2008.
- Mayer, K.E. and W.F. Laudenslayer, Jr., Eds. 1988. *A Guide to Wildlife Habitats of California*. State of California, Resources Agency, Department of Fish & Game.
- Miles, S.R. and C.B. Goudey. 1997. *Ecological Subregions of California: Section and Subsection Descriptions*. USDA Forest Service R5-EM-TP-005.
- Mladenoff, D., J. Sickley, and A.P. Wydeven. 1999. Predicting gray wolf landscape recolonization: logistic regression models vs. new field data. *Ecol. Appl.* 9: 37-44.
- Montana Department of Transportation 2006. US 93 Preconstruction wildlife monitoring field methods handbook. FHWA/MT-06-008/1744-2.
- Mumme, R.L., S.J. Schoech, G.E. Woolfenden, and J.W. Fitzpatrick. 2000. Life and death in the fast lane: Demographic consequences of road mortality in the Florida scrub-jay. *Cons. Biol.* 14: 501-512.
- Ng, S.J., J.W. Dole, R.M. Sauvajot, S.P.D. Riley, and T.J. Valone. 2004. Use of highway undercrossings by wildlife in southern California. *Biol. Cons.* 115: 499 – 507.
- Peery, M. Z., 2004. Power to Detect Trends in Pallid and Shovelnose Sturgeon Populations in the Missouri River. Sustainable Ecosystems Institute.
- Penrod, K., R. Hunter, and M. Merrifield. 2001. Missing Linkages: Restoring Connectivity to the California Landscape, Conference Proceedings. Co-sponsored by California Wilderness Coalition, The Nature Conservancy, U.S. Geological Survey, Center for Reproduction of Endangered Species, and California State Parks.
- Perrin, J. and R. Disegni. 2003. Safety Benefits of UDOT Highway Program, Animal-Vehicle Accident Analysis. Salt Lake City, Utah DOT. Available at: <http://www.dot.state.ut.us/dl.php/200312091625312/save/UT-03.31.pdf>.
- Pollock, K.H., J.D. Nichols, T.R. Simons, G.L. Farnsworth, L.L. Bailey, and J.R. Sauer. 2002. Large scale wildlife monitoring studies: statistical methods for design and analysis. *Environmetrics* 13: 105-119.
- Puky, M. 2003. Amphibian mitigation measures in Central-Europe. Proceedings of the International Conference on Ecology and Transportation, Lake Placid, NY, August 24-29, 2003.
- Pulliam, H.R. 1988. Sources, sinks, and population regulation. *American Naturalist* 132: 652-661.
- Putman, R.J. 1997. Deer and road traffic accidents: Options for management. *J. Wildl. Manage.* 51: 43-57.

- Pyke, C.R. 2005. Assessing suitability for conservation action: prioritizing interpond linkages for the California tiger salamander. *Cons. Biol.* 19: 492-503.
- Ralph, C. J., G.R. Geupel, P. Pyle, T.E. Martin, and D.F. DeSante. 1993. Handbook of Field Methods for Monitoring Land Birds. Pacific Southwest Research Station Report. PSW-GTR-144. 41 pp.
- Reading, C.J. 1989. Opportunistic predation of common toads *Bufo bufo* at a drift fence in southern England. In: Langton, T.E.S. (Ed.), *Amphibians and Roads. Proceedings of the Toad Tunnel Conference. Rendsburg, Federal Republic of Germany, 7-8 January 1989.* ACO Polymer Products, Bedfordshire, England, pp. 105-112.
- Reed, D.F. and T.N. Woodard. 1981. Effectiveness of Highway Lighting in Reducing Deer-Vehicle Accidents. *J. Wildlife Manage.* 45: 721-726
- Riley, S.P.D., J.P. Pollinger, R.M. Sauvajot, E.C. York, C. Bromley, T.K. Fuller, and R.K. Wayne. 2006. A southern California freeway is a physical and social barrier to gene flow in carnivores. *Mol. Ecol.* 15: 1733-1741.
- Roe, J.H., J. Gibson, and B.A. Kingsbury. 2006. Beyond the wetland border: estimating the impact of roads for two species of water snakes. *Biol. Cons.* 130: 161-168.
- Rubin, E., W.M. Boyce, M.C. Jorgensen, S.G. Torres, C.L. Hayes, C.S. O'Brien, and D.A. Jessup. 1998. Distribution and abundance of bighorn sheep in the Peninsular Ranges, California. *Wildl. Soc. Bull.* 26: 539-551.
- Sanderson, G.C. 1966. The Study of Mammal Movements: A Review. *J. Wildl. Manage.* 30: 215 – 235.
- Sawyer, J.O. and T. Keeler-Wolf. 1995. *A Manual of California Vegetation.* California Native Plant Society. (on-line at: <http://davisherb.ucdavis.edu/cnpsActiveServer/index.html>)
- Shilling, F.M., E.H. Girvetz, C. Erichsen, B. Johnson, and P.C. Nichols. 2002. A guide to wildlands conservation planning in the Greater Sierra Nevada Bioregion. California Wilderness Coalition, 187 p. Available at: <http://cain.nbio.org/repository/Sierra.pdf>
- Shilling, F.M. and E. Girvetz. 2007. Barriers to implementing a wildland network. *Landscape and Urban Planning* 80: 165-172.
- Sikich, J. and S. Riley. 2007. Effects of State Route 23 Widening Project on Culvert Use and Road Mortality of Wildlife. Santa Monica Mountains N.R.A., National Park Service Final Pre-construction Monitoring Report.
- Singer, F.J. and J.L. Doherty. 1985. Managing mountain goats at a highway crossing. *Wildl. Soc. Bull.* 13: 469-477.
- Small, A. 1994. *California Birds: Their Status and Distribution.* Ibis Publishing. 342 pp.

- Smallwood, S. and E.L. Fitzhugh. 1995. A track count for estimating mountain lion *Felis concolor californica* population trend. *Biol. Cons.* 71: 251-259.
- Smith, D.J. 1999. Identification and prioritization of ecological interface zones on state highways in Florida. Proceedings of the Third International Conference on Wildlife Ecology and Transportation, FL-ER-73-99, Florida Department of Transportation, Tallahassee, 1999, pp. 209-230. Available at: <http://www.dot.state.fl.us/EMO/sched/montana2.pdf>.
- Smith, J.N.M. and J.J. Hellmann. 2002. Population persistence in fragmented landscapes. *Trends in Ecology and Evolution* 17: 397-399.
- Stebbins, R.C. 2003. *A Field Guide to Western Reptiles and Amphibians*. Third Edition. Houghton Mifflin. 560 pp.
- Sullivan, T.L., A.E. Williams, T.A. Messmer, L.A. Hellinga, and S.Y. Kyrychenko. 2004. Effectiveness of temporary warning signs in reducing deer-vehicle collisions during mule deer migrations. *Wildl. Soc. Bull.* 32: 907-915.
- Sutherland, W.J. 2006. *Ecological Census Techniques: A Handbook*. 2nd Ed. Cambridge: Cambridge Univ. Press.
- Taylor, B.D. and R.L. Goldingay. 2003. Cutting the carnage: wildlife usage of road culverts in north-eastern New South Wales. *Wildlife Research* 30: 529-537.
- Theobald, D.M., J.R. Miller, and N.T. Hobbs. 1997. Estimating the cumulative effects of development on wildlife habitat. *Landscape and Urban Planning* 39: 25-36.
- Thorne, J., R. Cameron, and V. Jigour. 2002. *Guide to Wildlands Conservation for the Central Coast of California*. California Wilderness Coalition. Available as pdf at: <http://cain.nbii.org/repository/CC.pdf>
- Toft, C.A. and P.J. Shea. 1983. Detecting communitywide patterns: estimating power strengthens statistical inference. *American Naturalist* 122:618-625.
- Transportation Research Board. 2002. *Interaction Between Roadways and Wildlife Ecology*. A synthesis of highway practice. National Cooperative Highway Research Program, Transportation Research Board, The National Academies. Washington, D.C. Available as pdf at: [http://onlinepubs.trb.org/onlinepubs/nchrp/nchrp\\_syn\\_305.pdf](http://onlinepubs.trb.org/onlinepubs/nchrp/nchrp_syn_305.pdf)
- Trombulak, S.C. and C.A. Frissell. 2000. Review of ecological effects of roads on terrestrial and aquatic communities. *Cons. Biol.* 14: 18-30.
- Twitty, V.C. 1941. Data on the life history of *Ambystoma tigrinum californiense* Gray. *Copeia* 1941: 1-4.

- Van Der Grift, E. and R. Pouwels. 2006. Restoring habitat connectivity across transport corridors: identifying high-priority locations for de-fragmentation with the use of an expert-based model. Chap. 10 in: J. Davenport and J.L. Davenport, Eds. *The Ecology of Transportation: Managing Mobility for the Environment*. AA Dordrecht, The Netherlands: Springer.
- Van der Zande, A.N., W.J. ter Keurs, and W.J. van der Weijden. 1980. The impact of roads on the densities of four bird species in an open field habitat – evidence of a long distance effect. *Biol. Cons.* 18: 299-321.
- Waller, J.S. and C. Servheen. 2005. Effects of transportation infrastructure on grizzly bears in northwestern Montana. *J. Wildl. Manage.* 69: 985-1000.
- Warner, R.E., and K.M. Hendrix, editors. 1984. *California Riparian Systems: Ecology, Conservation, and Productive Management*. Berkeley: University of California Press.
- Welsh, H.H. and L.M. Ollivier. 1998. Stream amphibians as indicators of ecosystem stress: a case study from California's redwoods. *Ecol. Appl.* 8: 1118-1132.
- White, P.A. and M. Ernst. 2003. *Second Nature: improving transportation without putting nature second*. Defenders of Wildlife Surface Transportation Policy Project. Available from U.C. Davis Road Ecology Center (<http://repositories.cdlib.org/cgi/viewcontent.cgi?article=1201&context=jmie/roadecco>)
- Wilson, D.E., F.R. Cole, J.D. Nichols, R. Rudran, and M.S. Foster. 1996. *Measuring and Monitoring Biodiversity: Standard Methods for Mammals*. Washington and London: Smithsonian Institution Press.
- Woods, J.G. 1990. Effectiveness of fences and underpasses on the Trans-Canada Highway and their impact on ungulates populations project (Final Report). Parks Canada. Banff National Park Warden Service, Banff, Alberta, Canada.
- Woods, J.G., D. Paetkau, D. Lewis, B.N. McLellan, M. Proctor, and C. Strobeck. 1999. Genetic tagging of free-ranging black and brown bears. *Wildl. Soc. Bull.* 27: 616 – 627.
- Yanes, M., J.M. Velasco, and F. Suárez. 1995. Permeability of roads and railways to vertebrates: the importance of culverts. *Biol. Cons.* 71: 217-222.
- York, E.C., T.L. Moruzzi, T.K. Fuller, J. Organ, R.M. Sauvajot, and R.M. DeGraff. 2001. Description and evaluation of an inexpensive remote camera and triggering system for monitoring carnivores. *Wildl. Soc. Bull.* 29: 1228-1237.
- Zielinski, W. J., and H. B. Stauffer. 1996. Monitoring *Martes* populations in California: survey designs and power analysis. *Ecological Applications* 6:1254-1267.

## ***6.1 On-line Resources Cited***

Wildlife and Roads: A collaborative resource among the U.S.G.S., Utah State University, and the Transportation Research Board of the National Academies of Sciences for helping to mitigate roads for wildlife: <http://www.wildlifeandroads.org/index.cfm>

Surface Transportation Policy Project: [http://www.transact.org/default\\_ct\\_2\\_17\\_06.asp](http://www.transact.org/default_ct_2_17_06.asp)

UCSB Ventura County Report: [http://www.bren.ucsb.edu/research/documents/corridors\\_final.pdf](http://www.bren.ucsb.edu/research/documents/corridors_final.pdf)

Maureen Hartmann's Evaluation of Wildlife Crossing Structures: Their Use and Effectiveness, on the Wildlands web site; accessed 8/07; <http://www.wildlandscpr.org/evaluation-wildlife-crossing-structures-their-use-and-effectiveness>

Federal Highway Administration (FHWA) Critter Crossings Web site:  
<http://www.fhwa.dot.gov/environment/wildlifecrossings/>

Federal Highway Administration. 2002. Wildlife Habitat Connectivity Across European Highways. Office of International Programs, Federal Highway Administration, available at: [http://international.fhwa.dot.gov/wildlife\\_web.htm](http://international.fhwa.dot.gov/wildlife_web.htm)

Center for Transportation and the Environment (CTE) at North Carolina State University, at: <http://www.itre.ncsu.edu/CTE/index.asp>

Western Transportation Institute at Montana State University: <http://www.coe.montana.edu/wti/>

# 7 Appendices

## 7.1 Definitions

Definitions derived from Designing Road Crossings for Safe Wildlife Passage: Ventura County Guidelines; available at: [http://www.bren.ucsb.edu/research/documents/corridors\\_final.pdf](http://www.bren.ucsb.edu/research/documents/corridors_final.pdf).

**Connectivity:** The degree to which the landscape facilitates or impedes movement among habitat patches (Taylor and Goldingay, 2003). The concept of connectivity is used to describe how the spatial arrangement and quality of elements in the landscape affect the movement of organisms among habitat patches (Merriam, 1984; Taylor and Goldingay, 2003; Forman and Alexander, 1998).

**Crossing Structure:** A structure such as a pipe, culvert, bridge underpass or overpass that may be used by wildlife for passage over or under a roadway. Most traditional crossing structures are primarily intended to facilitate the flow of water. Studies have shown the crossing structures can also facilitate wildlife passage, reduce wildlife mortality from vehicle collisions, improve highway safety, and improve habitat connectivity.

**Crossing Substrate:** The surface material composing the bottom of the crossing structure.

**Functional Group:** A group of species that tend to prefer similar crossing structure design characteristics (see Section 3.4.1, above). Note that this term is not a scientific classification system.

**Landscape linkage:** a large regional arrangement of habitat, not necessarily linear or continuous, that enhances the movement of animals or the continuity of ecological processes at the landscape level (Bennett, 2003). A landscape linkage may include numerous wildlife movement corridors.

**Rescue Effect:** the emigration or movements of individuals from an area with a relatively large number of individuals (large local population) into an area with a relatively low number of individuals to rescue this population from local extinction. Related to source and sink habitats, below.

**Riparian:** plant communities contiguous to and affected by surface and subsurface hydrologic features of perennial and intermittent lotic and lentic water bodies such as rivers, streams, lakes, or drainage ways. Riparian areas have one or both of the following characteristics: 1) distinctively different vegetative species than adjacent areas, and 2) species similar to adjacent areas but exhibiting more vigorous or robust growth forms. Riparian areas are usually transitional between wetland and upland habitats (U.S. Fish & Wildlife Service/National Wetlands Inventory, 1997).

**Sink Habitat:** an area of habitat that is unable to support a viable long-term population by itself. A sink habitat offers suitable short-term cover, food, and water to animals, but production of young in a local population is less than the mortality rate.



**Source Habitat:** an area of habitat that is able to support a viable long-term population by itself. A source habitat offers suitable long-term cover, food, and water to animals, and productivity rate in the local population is greater than the mortality rate, resulting in net surpluses of individuals (population growth or source of additional individuals for dispersal to other regions).

**Wetland:** lands that are transitional between terrestrial and aquatic systems where the water table is usually at or near the surface or the land is periodically covered with shallow water; they generally contain plant communities that are adapted to periodic inundation. The frequency of occurrence of water is sufficient to support a prevalence of vegetative or aquatic life that requires saturated or seasonally saturated soil conditions for growth and reproduction. Wetlands include marshes, bogs, sloughs, vernal pools, wet meadows, river and stream overflows, mudflats, ponds, springs, and seeps.

**Wildlife Crossing:** 1) a region of concentrated animal movement where it intercepts a road. 2) a structure that facilitates the movement of animals from one side of a road to the other.

**Wildlife Movement Corridor:** A swath of wildlife habitat, generally vegetated, which joins two or more larger areas of wildlife habitat.

## ***7.2 U.S. Fish & Wildlife Service Recommended Specifications for Desert Tortoise Exclusion Fencing***

The following desert tortoise exclusion fencing specifications were derived from the U.S. Fish & Wildlife Service, Southwest Region 2, Arizona Ecological Services Field Office website at: <http://www.fws.gov/southwest/es/arizona/Documents/SpeciesDocs/DesertTortoise/Tortoise%20Fencing.pdf> accessed 01/2008.

### **RECOMMENDED SPECIFICATIONS FOR DESERT TORTOISE EXCLUSION FENCING September 2005**

These specifications were developed to standardize fence materials and construction procedures to confine tortoises or exclude them from harmful situations, primarily roads and highways. Prior to commencing any field work, all field workers should comply with all stipulations and measures developed by the jurisdictional land manager and the U.S. Fish and Wildlife Service for conducting such activities in desert tortoise habitat, which will include, at a minimum, completing a desert tortoise education program.

#### **FENCE CONSTRUCTION**

##### **Materials**

Fences should be constructed with durable materials (*i.e.*, 16 gauge or heavier) suitable to resist desert environments, alkaline and acidic soils, wind, and erosion. Fence material should consist of 1-inch horizontal by 2-inch vertical, galvanized welded wire, 36 inches in width. Other materials include: Hog rings, steel T-posts, and smooth or barbed livestock wire. Hog rings should be used to attach the fence material to existing strand fence. Steel T-posts (5 to 6-foot) are used for new fence construction. If fence is constructed within the range of bighorn sheep, 6-foot T-posts should be used (see New Fence Construction below). Standard smooth livestock wire fencing should be used for new fence construction, on which tortoise-proof fencing would



be attached.

#### Retrofitting Existing Livestock Fence

**Option 1 (see illustration below).** Fence material should be buried a minimum of 12 inches below the ground surface, leaving 22-24 inches above ground. A trench should be dug or a cut made with a blade on heavy equipment to allow 12 inches of fence to be buried below the natural level of the ground. The top end of the tortoise fence should be secured to the livestock wire with hog rings at 12 to 18-inch intervals. Distances between T-posts should not exceed 10 feet, unless the tortoise fence is being attached to an existing right-of-way fence that has larger interspaces between posts. The fence must be perpendicular to the ground surface, or slightly angled away from the road, towards the side encountered by tortoises. After the fence has been installed and secured to the top wire and T-posts, excavated soil will be replaced and compacted to minimize soil erosion.

**Option 2 (see illustration below).** In situations where burying the fence is not practical because of rocky or undigable substrate, the fence material should be bent at a 90E angle to produce a lower section approximately 14 inches wide which will be placed parallel to, and in direct contact with, the ground surface; the remaining 22-inch wide upper section should be placed vertically against the existing fence, perpendicular to the ground and attached to the existing fence with hog rings at 12 to 18-inch intervals. The lower section in contact with the ground should be placed within the enclosure in the direction of potential tortoise encounters and level with the ground surface. Soil and cobble (approximately 2 to 4 inches in diameter; can use larger rocks where soil is shallow) should be placed on top of the lower section of fence material on the ground covering it with up to 4 inches of material, leaving a minimum of 18 inches of open space between the cobble surface and the top of the tortoise-proof fence. Care should be taken to ensure that the fence material parallel to the ground surface is adequately covered and is flush with the ground surface.

#### New Fence Construction

Options 1 or 2 should be followed except in areas that require special construction and engineering such as wash-out sections (see below). T-posts should be driven approximately 24 inches below the ground surface spaced approximately 10 feet apart. Livestock wire should be stretched between the T-posts, 18 to 24 inches above the ground to match the top edge of the fence material; desert tortoise-proof fencing should be attached to this wire with hog rings placed at 12 to 18-inch intervals. Smooth (barb-less) livestock wire should be used except where grazing occurs.

If fence is constructed within the range of bighorn sheep, two smooth-strand wires are required at the top of the T-post, approximately 4 inches apart, to make the wire(s) more visible to sheep. A 20 to 24-inch gap must exist between the top of the fence material and the lowest smooth-strand wire at the top of the T-post. The lower of the top two smooth-strand wires must be at least 43 inches above the ground surface. (72-inch T-posts: 24 inches below ground + 18 inches of tortoise fence above ground + 20 to 24-inch gap to lower top wire + 4 inches to upper top wire = 66 to 70 inches).

#### INSPECTION OF DESERT TORTOISE BARRIERS

The risk level for a desert tortoise encountering a breach in the fence is greatest in the spring and fall, particularly around the time of precipitation including the period during which precipitation occurs and at least several days afterward. All desert tortoise fences and cattleguards should be inspected on a regular basis sufficient to maintain an effective barrier to tortoise movement. Inspections should be documented in writing and include any observations of entrapped animals; repairs needed including bent T-posts, leaning or non-perpendicular fencing, cuts, breaks, and gaps; cattleguards without escape paths for tortoises or needed maintenance; tortoises and tortoise burrows including carcasses; and recommendations for supplies and equipment needed to complete repairs and maintenance.

All fence and cattleguard inventories should be inspected at least twice per year. However, during the first 2 to 3 years all inspections will be conducted quarterly at a minimum, to identify and document breaches, and problem areas such as wash-outs, vandalism, and cattleguards that fill-in with soil or gravel. GPS coordinates and mileages from existing highway markers should be recorded in order to pinpoint problem locations and build a database of problem locations that may require more frequent checking. Following 2 to 3 years of initial inspection, subsequent inspections should focus on known problem areas which will be inspected more frequently than twice per year. In addition to semi-annual inspections, problem areas prone to wash-outs should be inspected following precipitation that produces potentially fence-damaging water flow. A database of problem areas will be established whereby checking fences in such areas can be done efficiently.

#### **REPAIR AND MAINTENANCE OF DESERT TORTOISE BARRIERS**

Repairs of fence wash-outs: (1) realign the fence out of the wash if possible to avoid the problem area, or (2) re-construct tortoise-proof fencing using techniques that will ensure that an effective desert tortoise barrier is established that will not require frequent repairs and maintenance.

Gaps and breaks will require either: (a) repairs to the existing fence in place, with similar diameter and composition of original material, (b) replacement of the damaged section to the nearest T-post, with new fence material that original fence standards, (c) burying fence, and/or (d) restoring zero ground clearance by filling in gaps or holes under the fence and replacing cobble over fence constructed under Option 2. Tortoise-proof fencing should be constructed and maintained at cattleguards to ensure that a desert tortoise barrier exists at all times.

All fence damage should be repaired in a timely manner to ensure that tortoises do not travel through damaged sections. Similarly, cattleguards will be cleaned out of deposited material underneath them in a timely manner. In addition to periodic inspections, debris should be removed that accumulates along the fence. All cattleguards that serve as tortoise barriers should be installed and maintained to ensure that any tortoise that falls underneath has a path of escape without crossing the intended barrier.



DESERT TORTOISE EXCLUSION FENCE (2005)

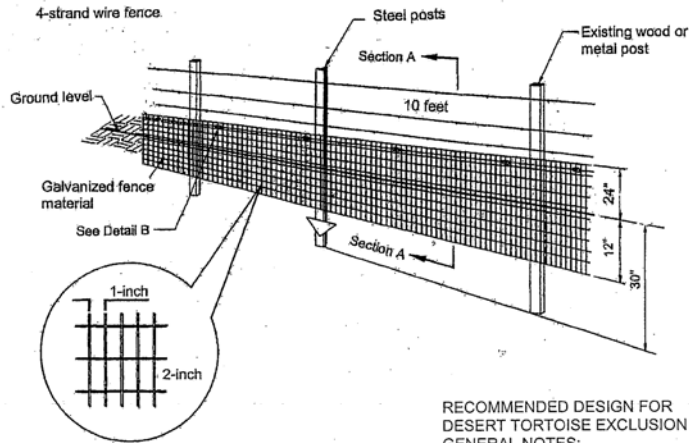

DETAIL A

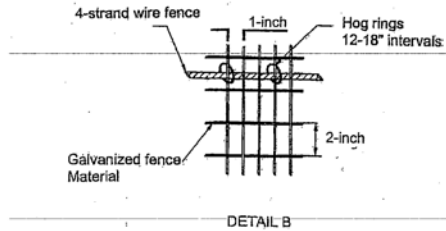

DETAIL B

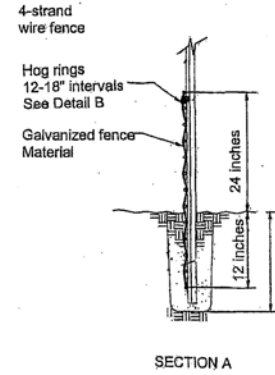

SECTION A

RECOMMENDED DESIGN FOR  
DESERT TORTOISE EXCLUSION FENCE  
GENERAL NOTES:

1. Ensure that fence posts and materials conform to the standards approved by the U.S. Fish and Wildlife Service.
2. Ensure that the height above ground level is no less than 18 inches and no higher than 24 inches.
3. Ensure that the depth of fence material below ground level is about 12 inches but no less than 6 inches. (See SECTION A above)
4. Install additional steel posts when span between existing fence posts exceed 10 feet.
5. Attach fence material to existing fence or wire using hog rings at 12-inch intervals.
6. Fasten fence material to posts with 3 tie wires with a wire near the top, bottom, and center of the fence material.
7. Backfill trenches with excavated material and compact the material.
8. Attach fence material to all gates. Ensure that clearance at base of gate achieves zero ground clearance.
9. Substitute smooth wire for barbed wire if additional support wires are necessary.
10. The number and placement of support wires may be modified to allow sheep and deer to pass safely.
11. Erosion at the edge of the fence material where the fence crosses washes may occur and requires appropriate and timely monitoring and repair.
12. Tie the fence into existing culverts and cattleguards when determined necessary to allow desert tortoise passage underneath roadways.

### 7.3 Deer One-way Gate Design Considerations

The following provides an example of design considerations for a one-way gate that is intended to allow deer and other large-bodied vertebrates to escape from roadway rights-of-way and is adapted from the Transport Canada web site, accessed 01/2008 (<http://www.tc.gc.ca/civilaviation/AerodromeAirNav/Standards/WildlifeControl/Deer/6c.htm>).

