



# Design of Bridges and Culverts for Wildlife Passages at Freshwater Streams

December 2010







# Design of Bridges and Culverts for Wildlife Passage at Freshwater Streams

December 2010

**The Commonwealth of Massachusetts**

Deval L. Patrick, Governor

**Department of Transportation**

Jeffrey B. Mullan, Secretary & Chief Executive Officer

**Highway Division**

Luisa Paiewonsky, Administrator

## ACKNOWLEDGEMENTS

The *Design of Bridges and Culverts for Wildlife Passage at Freshwater Streams* has been compiled through a collaborative effort between the Environmental, Bridge, Construction, and Hydraulics Sections of the Massachusetts Department of Transportation Highway Division.

MassDOT personnel who have contributed to this document include:

Lenny Aversa	Thomas McGuire
Henry Barbaro	Tim Meyer
Alex Bardow	Richard Murphy
Robert Boone	Amer Raza
William Clougherty	Larry Salvatore
Tim Dexter	Ann Sullivan
Jessica Kenny	Vicki Volz
Brett Loosian	

The following environmental and regulatory representatives have provided technical advice during the creation of this document.

Karen K. Adams, United States Army Corps of Engineers  
Carrie Banks, Division of Ecological Restoration, Mass Dept. Fish and Game  
Christopher Boelke, National Marine Fisheries Service  
Alison Bowden, The Nature Conservancy  
Scott Jackson, University of Massachusetts Amherst  
Georgeann Keer, Division of Ecological Restoration, Mass Dept. Fish and Game  
Greg Penta, United States Army Corps of Engineers  
Tim Purinton, Division of Ecological Restoration, Mass Dept. Fish and Game  
Edward Reiner, United States Environmental Protection Agency  
John Sargent, United States Army Corps of Engineers

David Nyman, P.E. of Comprehensive Environmental Inc. has provided technical advice and has played a key role in compiling this document.



Deval L. Patrick, Governor  
Timothy P. Murray, Lt. Governor  
Jeffrey B. Mullan, Secretary & CEO  
Luisa Paiewonsky, Administrator



December 22, 2010

### Design of Bridges and Culverts for Wildlife Passage at Freshwater Streams

The Massachusetts Department of Transportation, Highway Division (MassDOT) is pleased to present *The Design of Bridges and Culverts for Wildlife Passage at Freshwater Streams* guidance handbook. Context Sensitive Design, one of the Guiding Principles of MassDOT's *Project Development and Design Guide*, requires the development of transportation facilities that fit the environmental resources setting, while maintaining safety and mobility for all users. Chapter 14 of the *Guide* specifically addresses wildlife accommodation along new and existing roadways. *The Design of Bridges and Culverts for Wildlife Passage at Freshwater Streams* expands on that guidance, focusing on structures at inland stream crossings.

MassDOT recognizes the importance of designing new and replacement bridges and culverts to accommodate, to the extent practicable, fish and other wildlife passage at road and stream crossings. This guidance document will assist project planners and designers in addressing wildlife passage and in complying with regulatory standards for these structures. The handbook has been compiled under the direction of the Highway Division's Environmental Section, with input solicited from other MassDOT personnel, state and federal natural resources and regulatory agencies, and other professionals versed in wildlife accommodation issues.

We look forward to the implementation of this important component of Context Sensitive Design as part of our continuing efforts to provide and manage a safe, effective, and sustainable transportation system for the Commonwealth of Massachusetts.

Luisa Paiewonsky  
Administrator  
Highway Division  
Massachusetts Department of Transportation



# Contents

- 1.0 Introduction..... 1**
- 2.0 The Massachusetts River and Stream Crossing Standards ..... 7**
  - 2.1 Rationale for Designing Stream Crossings for Habitat Continuity ..... 7
  - 2.2 Evaluating Existing Crossings Relative to Wildlife Passage..... 12
  - 2.3 Introduction to the Massachusetts River and Stream Crossing Standards ..... 15
  - 2.4 Determining the Bankfull Width of a River or Stream..... 20
  - 2.5 Determining “Openness” ..... 24
  - 2.6 Thresholds for Optimum Standards ..... 25
  - 2.7 Regulatory Context ..... 27
    - 2.7.1 US Army Corps of Engineers Massachusetts General Permit..... 28
    - 2.7.2 US Army Corps of Engineers Comprehensive Permit for Bridges ..... 32
    - 2.7.3 Massachusetts 401 Water Quality Certification Regulations ..... 33
- 3.0 Criteria for Wildlife Passage at Bridges and Culverts ..... 37**
  - 3.1 Criteria for Maintenance Activities ..... 38
  - 3.2 Criteria for Replacements of Existing Stream Crossings that Are Not Considered Maintenance Activities ..... 41
  - 3.3 Criteria for Structures at New Stream Crossings ..... 45
  - 3.4 Exceptions ..... 46
  - 3.5 Constraints Analysis ..... 47
  - 3.6 Order of Preference of Alternatives ..... 48
- 4.0 Design Approaches for Wildlife Passage at Stream Crossings ..... 51**
  - 4.1 Range of Ecological Solutions ..... 51
  - 4.2 Summary Descriptions of Design Approaches ..... 53
    - 4.2.1 Valley Span ..... 56
    - 4.2.2 Stream Span ..... 59
    - 4.2.3 Stream Simulation ..... 62
    - 4.2.4 No-Slope Culvert ..... 67
    - 4.2.5 Bridge Replacement with Retained Abutments..... 70

4.2.6	Full Span Embedded Multiple-Box Culvert.....	74
4.2.7	Roughened Channel Embedded Culvert .....	78
4.2.8	Simple Embedded Culvert.....	82
4.2.9	Fish Passage Hydraulic Design .....	85
4.2.10	Flow Conveyance Design .....	89
4.3	Supplemental Measures .....	91
<b>5.0</b>	<b>Constraints on Providing Passable Stream Crossings.....</b>	<b>93</b>
5.1	General Discussion of Design Constraints.....	93
5.2	Typical Considerations and Constraints at Stream Crossing Structures .....	94
5.3	Constraints Affecting Replacement of Existing Crossing Structures .....	97
<b>6.0</b>	<b>Project Development and Design for Stream Crossings .....</b>	<b>107</b>
6.1	MassDOT Project Development and Design Guide .....	107
6.2	MassDOT Bridge Manual .....	107
6.3	Design Development Requirements and Stream Continuity .....	109
6.4	Priorities of the Design Technique Options .....	112
<b>References:</b>	.....	<b>115</b>

## List of Tables

Table 2-1.	Passage Classification for Existing Stream Crossing Structures.....	13
Table 2-2.	Summary of the Massachusetts River and Stream Crossing Standards .....	17
Table 2-3.	Equations for Estimating Bankfull-Channel Geometry and Discharge for Streams in the Northeastern United States (Source: Bent, 2006) .....	23
Table 2-4.	Eligibility Requirements for MassDOT Stream Crossing Structures under ACOE Comprehensive Permit for Bridges and MA General Permit Categories 1 and 2.....	35
Table 3-1.	Order of Preference for Alternative Design Measures for Maximizing Wildlife Passage .....	49
Table 4-1.	Stream Crossing Design Approaches.....	53
Table 4-2.	Supplemental Measures at Stream Crossings .....	91
Table 5-1.	Designing Bridges and Culverts to Meet the Massachusetts River and Stream Crossing Standards: Potential Design Constraints.....	95
Table 6-1.	Project Development and Design Guide Provisions for Habitat Continuity at Stream Crossings	108



## List of Figures

Figure 2-1. “Perched” Culverts Fragment Aquatic Habitat.....	10
Figure 2-2. Conditions Affecting Wildlife Passage at Culverts.....	11
Figure 2-3. Stream Simulation Culvert Design .....	16
Figure 2-4. Bankfull Channel Width.....	21
Figure 2-5. Openness for Culverts and Bridges .....	24
Figure 3-1. MassDOT Project Wildlife Accommodation Scenarios for New and Replacement Stream Crossings.....	42
Figure 4-1. The Range of Ecological Design Solutions at Stream Crossings .....	52
Figure 4-2. Range of Stream Crossing Design Approaches (Adapted from Gubernick, 2003). .....	55
Figure 4-3. Valley Span.....	57
Figure 4-4. Stream Span .....	60
Figure 4-5. Stream Simulation .....	64
Figure 4-6. No-Slope Culvert.....	68
Figure 4-7. Bridge Replacement with Retained Abutments .....	72
Figure 4-8. Full Span Embedded Multiple-Box Culvert.....	76
Figure 4-9. Roughened Channel Embedded Culvert.....	80
Figure 4-10. Simple Embedded Culvert.....	83
Figure 4-11. Fish Passage Hydraulic Design.....	87
Figure 5-1. Example of Vertical Clearance Limitations for a Replacement Structure.....	97
Figure 5-2. Example of Wetland Impacts of Raising Approach Road to Reconstructed Stream Crossing.....	98
Figure 5-3. Potential Alteration of Upstream Wetlands as a Result of Culvert Replacement.....	100
Figure 5-4. Example of Measure to Prevent Headcutting. ....	101
Figure 5-5. Potential Alteration of Flood Elevations as a Result Culvert Replacement. ....	102
Figure 5-6. Utilities at Existing Crossings Can Limit Options for Replacement Structures. ....	104

# Appendices

**Appendix A.** Massachusetts River and Stream Crossing Standards

**Appendix B.** MassDOT Stream Crossing Structures Rating Chart and Related Information

**Appendix C.** US Army Corps of Engineers Massachusetts General Permit

**Appendix D.** US Army Corps of Engineers Massachusetts Department of Transportation Comprehensive Permit for Bridges

**Appendix E.** Massachusetts 401 Water Quality Regulations

## 1.0 Introduction

The Massachusetts Department of Transportation - Highway Division (MassDOT) has jurisdiction over numerous roadway stream crossings. Existing bridges and culverts, as well as future structures, potentially affect aquatic and terrestrial wildlife movement along the Commonwealth's streams and riparian corridors, which in turn potentially affects the viability of wildlife populations and ecological systems. MassDOT considers it important to design new and replacement stream crossings to accommodate fish and other wildlife passage and prevent adverse impacts to important ecological systems. Therefore, MassDOT has developed this guidance document to address wildlife passage issues at new and replacement bridges and culverts and to comply with regulatory standards for stream crossings.

In Massachusetts, state and federal regulations of stream crossings apply requirements based on the Massachusetts River and Stream Crossing Standards.<sup>1</sup> Chapter 2 of this document discusses these Standards in detail, along with the regulatory context in which the standards are applied. The remainder of the document presents MassDOT guidance on addressing the regulations and Standards. MassDOT anticipates that project planners and designers will use this guidance in conjunction with other standard MassDOT technical references to evaluate, select, and design stream crossings for conveyance capacity, structural integrity, and wildlife habitat continuity.

This document focuses on *fish and other wildlife passage* at new and replacement bridges and culverts at *freshwater streams*. At tidal stream crossings, wildlife habitat continuity and fish passage considerations differ from freshwater, non-tidal systems. Application of wildlife accommodation measures appropriate for freshwater systems may be ecologically unjustified for tidal systems. This document does not address tidal systems. As this document focuses on wildlife passage, it also does not specifically address other potential habitat impacts associated with placing structures in or over streams, such as permanent impacts on benthic resources, impacts resulting from shade, and stormwater management impacts. Project planners and designers should consult MassDOT environmental professionals and other MassDOT reference materials for direction about these issues.

MassDOT has developed this document in light of the overall guiding principles provided by the Department's *Project Development and Design Guide* (2006). The introduction of that principle guidance document for the design and implementation of transportation projects states:

*“Transportation and quality of life in our Commonwealth communities are inextricably linked. This connection is largely influenced by the role that highways, streets, and sidewalks play in our lives. Excellent transportation is critical to a healthy and vibrant Commonwealth...MassDOT [formerly MassHighway], in its role as steward for our roadways, must consider a broad range of factors in maintaining and improving this system, including:*

- *Safety for all users*

---

<sup>1</sup> Massachusetts River and Stream Continuity Partnership, 2006. Appendix A includes a copy of the current standards.

- *Functionality – the need for access and mobility*
- *Accessibility for people with disabilities – as a prerequisite to access to employment, recreation, and healthcare*
- *Mutual support and compatibility between transportation facilities and services and the adjacent land uses and associated activities they serve*
- *Consistency with transportation plans and policies, and environmental regulations, that guide the community, the region, the state, and the Federal government*
- *Transportation facility design and operational requirements established by others*
- *Input and participation from local constituents, and the appropriate local, regional and state reviewing agencies*
- *Cost effectiveness – the value returned to the Commonwealth for the investments made in transportation*

*“The Commonwealth of Massachusetts is committed to caring for the built and natural environments by promoting sustainable development practices that minimize negative impacts on natural resources, historic, scenic and other community values, while also recognizing that transportation improvements have significant potential to contribute to local, regional, and statewide quality of life and economic development objectives...”*

*“...Well-designed transportation infrastructure that is responsive to its context is the product of thoughtful planning. By bringing together transportation professionals, local residents, and interest groups, transportation planning can produce public facilities and programs that support community goals, provide safe and efficient transportation for individuals and goods, enhance the economy, and protect the natural environment.*

*“The purpose of [the] Project Development & Design Guide (Guidebook) is to provide designers and decision-makers with a framework for incorporating context sensitive design and multi-modal elements into transportation improvement projects. The emphasis is to ensure that investments in transportation infrastructure encourage projects that are sensitive to the local context while meeting the important needs of the people they serve.”*

In keeping with the overall direction established by the *Guidebook*, the chapters of this guidance document provide the following:

1. Introduction.
2. The Massachusetts River and Stream Crossing Standards.

This chapter presents an overview of the rationale for integrating wildlife passage elements into the design of bridges and culverts, describes a method for assessing the degree of wildlife passage

afforded by a structure, and summarizes the key elements of the *Massachusetts River and Stream Crossing Standards*.<sup>2</sup>

This chapter also describes the regulatory framework for developing stream crossing structures that provide habitat connectivity. This includes a discussion of the US Army Corps of Engineers Massachusetts General Permit, and the Comprehensive Permit for Bridges issued for qualifying MassDOT projects. The chapter also discusses the applicability of the Massachusetts 401 Water Quality Certification regulations and the Wetlands Protection Act Regulations.

### 3. Criteria for Wildlife Passage at Bridges and Culverts.

MassDOT activities include:

- The maintenance of roadway infrastructure, to provide for the continuing safety and serviceability of existing roadways;
- Reconstruction and replacement of roadways and roadway structures (such as bridges and culverts at stream crossings) to improve and upgrade existing roadways to meet evolving transportation needs and safety standards;
- Construction of new roadways to meet the transportation needs of the Commonwealth of Massachusetts.

For each of these broad categories of activities, there are differing opportunities and constraints for the provision of fish and other wildlife passage. Chapter 3 describes MassDOT's criteria for considering the needs for wildlife passage for maintenance activities involving culvert and bridge repair; projects for improvement/reconstruction of existing roadways, culverts, and bridges; and projects involving the planning, selection, and design of new stream crossing structures.

Subsequent chapters then discuss in detail the design methodologies and pertinent constraints for these criteria.

### 4. Design Approaches for Wildlife Passage at Stream Crossings.

Chapter 4 describes the general range of design approaches for conveyance of flows at stream crossings, while accommodating the passage of fish and other wildlife. The document briefly describes several specific design methods to achieve varying degrees of wildlife passage. These descriptions include suggested reference materials that the designer should consult for detailed procedures for the analysis and design of bridges and culverts to meet wildlife passage objectives. This guidance document does not present detailed design data, but rather cites potential technical resources that designers and reviewers can consult.

---

<sup>2</sup> The River and Stream Continuity Partnership, which includes the University of Massachusetts Amherst, Massachusetts Department of Fish and Game Riverways Program, and The Nature Conservancy, developed the *Massachusetts River and Stream Crossing Standards*.

## 5. Constraints on Providing Passable Stream Crossings.

This chapter identifies common design constraints that apply to the development of bridge and culvert designs. These constraints can apply to new and replacement crossings, but are particularly challenging at replacement structures, where past decisions can limit current opportunities because of concerns regarding hydraulic capacity, flood control, right-of-way limitations, structural integrity, other regulatory requirements, and construction feasibility. The designer needs to identify and characterize such constraints early in the design of bridge and culvert improvement projects. Definition of the constraints will enable collection of pertinent information for choosing a structure that would maximize compliance with the River and Stream Crossing Standards, while addressing other critical design parameters and balancing habitat continuity objectives against other regulatory requirements.

## 6. Project Development and Design for Stream Crossings.

This chapter describes how MassDOT's project development and design process integrates provisions for complying with the Massachusetts River and Stream Crossing Standards. The Massachusetts Highway *Project Development and Design Guide* (2006) and the *Bridge Design Manual* include key provisions that ensure that the project initiation, planning, development, and design process considers habitat continuity at stream crossings, provides for coordination with affected environmental agencies, and incorporates crossing design measures to achieve compliance with applicable regulations.

The MassDOT handbook *Design of Bridges and Culverts for Wildlife Passage at Freshwater Streams* is not a stand-alone document. The design of stream crossings with adequate flow capacity, structural integrity, and wildlife habitat continuity will require the designer to use this guidance in conjunction with the following documents and other technical references on the design of highway structures:

- The MassDOT (formerly MassHighway) *Project Development and Design Guide* (2006), in particular the following chapters:
  - Chapter 2 – Project Development;
  - Chapter 8 - Drainage and Erosion Control;
  - Chapter 10 – Bridges;
  - Chapter 14 - Wildlife Accommodation.
- The MassDOT *Bridge Manual* (2007),<sup>3</sup> and in particular, the following chapter:
  - Chapter 2 - Preliminary Engineering Guidelines.

---

<sup>3</sup> At the time of publication of this Handbook, MassDOT is in the process of developing the *LRFD Bridge Manual*. This handbook is intended to be consistent with MassDOT bridge design practice; designers should consult the most current design practices adopted by MassDOT in conjunction with the use of this guidance on wildlife accommodation.

- *Massachusetts River and Stream Crossing Standards* (March 1, 2006, included as Appendix A of this document), and future updates of these Standards, as applicable.
- The MassDOT Stream Crossing Structures Rating Chart, and the related River/Stream Continuity Project resource materials (included as Appendix B of this document) for evaluating existing crossings relative to their wildlife passage characteristics, including:
  - MassDOT Stream Crossing Structures Rating Chart (and future updates, as applicable);
  - Stream Continuity Partnership Road-Stream Crossing Inventory (Field Data Form);
  - Instruction Guide for Field Data Sheet: Road-Stream Crossing Inventory.
- Applicable regulations governing stream crossings, including:
  - USACE Massachusetts General Permit (MGP), included as Appendix C;
  - USACE MassDOT Comprehensive Permit for Bridges (CPB), included as Appendix D;
  - Massachusetts 401 Water Quality Certification Regulations (Appendix E); and
  - Other regulations as applicable.
- Other technical design references cited in this document, containing detailed evaluation and design methodologies for achieving wildlife passage at culverts and bridges.

### Important Note on Terminology Used in this Handbook

MassDOT terminology for “bridges” as used in various Department reference materials encompasses a wide variety of structures, including both clear-span type structures and some culvert-type structures.\* For the purposes of this handbook, the following convention for terminology will be followed:

**Bridge:** A structure that supports a roadway or other access way over a water body by means of a span. This type of structure does not have a constructed structural invert (bottom) and therefore does not fully enclose the channel that it spans. It may consist of a deck supported on abutments or piers, open-bottom box or half-pipe, or other structural arch.

**Culvert:** A structure that supports a roadway or other access way over a water body by means of a fully enclosed conduit (complete pipe or box) that always has a constructed bottom and does not typically have abutments or piers. Common culvert types include circular (round) pipe, elliptical pipe, pipe-arch (a “squashed” round pipe cross section), and square or rectangular box. Culverts may or may not be “embedded” (an installation where streambed material is placed or allowed to accumulate in the bottom of the conduit).

\* For example, MassDOT may assign a culvert a “Bridge Number” and consider it a “bridge” under certain jurisdictional contexts.





## 2.0 The Massachusetts River and Stream Crossing Standards

This chapter discusses the underlying reasons for designing stream crossings to provide for unobstructed wildlife passage, or habitat continuity. The chapter explains how conditions at culverts and bridges can create barriers to aquatic and other wildlife passage, and presents a method for assessing existing structures relative to the degree they allow for wildlife passage. The chapter then introduces the Massachusetts River and Stream Crossing Standards. It also summarizes the regulatory framework governing the design of bridges and culverts to provide for habitat continuity.

### 2.1 Rationale for Designing Stream Crossings for Habitat Continuity

Continuous, unobstructed stream systems are critical to maintaining healthy, viable ecosystems. Stream continuity is also essential to the survival of individuals and sub-populations of wildlife species that use stream and riparian habitat.

New and existing bridges and culverts can interrupt the continuity of stream systems, imposing structural, hydraulic, and behavioral barriers to the movement of fish and other wildlife. Historically, stream crossing structures have been designed to address traffic considerations, structural integrity, and hydraulic capacity. Crossing structures can also be designed to address the unobstructed movement of wildlife. The rationale for providing wildlife passage is discussed below.

Consider the following comparison of transportation systems and stream systems:

#### **Ground transportation systems**

Highways, roads, railroads, bicycle paths, and pedestrian ways are linear systems. They are indispensable to the movement of people and materials across the landscape. If a roadway network is interrupted by an obstruction, then points of origin and destination along the roadway become isolated from each other.

If a roadway is constructed along an alignment that meets a river or stream, then a suitable crossing is required to provide continuity of the roadway across the stream. If the crossing is a bridge, then to provide adequate and continuous access, the bridge must have a width, slope, and surface treatment that provides for the free flow of traffic across the structure.

Bridges are designed to be continuous in horizontal and vertical alignment with the approaching roadway, and to accommodate the vehicle types, sizes, speeds, and traffic volumes using the approaching roadways. Bridges not meeting all these criteria would restrict or obstruct the flow of traffic – potentially isolating points of origin and destination from each other.

#### **Stream systems**

Rivers, brooks, and streams are linear ecosystems. Stream channels and adjacent riparian corridors are critical to the movement of aquatic and terrestrial wildlife across the landscape, together with materials (large and small woody debris, organic detritus, and nutrients) that affect their habitat. If a

stream is interrupted by an obstruction, then essential ecological infrastructure is undermined and habitats along the corridor become isolated from each other (a condition referred to as “fragmentation”).

If a stream alignment crosses a transportation system alignment, then a suitable crossing is required to provide continuity of the stream habitat across the transportation corridor. For ecological continuity, if a bridge or culvert crossing is provided, then the opening that accommodates the stream must have a width, slope, and surface treatment that provides for the free flow of the “ecological traffic” through the structure. In this case, the flow through the structure includes the passage of water, sediment, and natural debris, and in addition both the upstream and downstream movement of aquatic organisms. Moreover, terrestrial movement along the stream corridor is also important to ecosystem integrity.

For habitat continuity, the crossings must be designed to be continuous with the horizontal and vertical alignment of the upstream and downstream channel, to convey the flow of sediment and natural debris as well as water, and to accommodate the full range of wildlife types, life stages, movement abilities, and movement behaviors found in the nearby stream system. Crossings not meeting all these criteria would obstruct the passage of wildlife – potentially isolating critical areas of the ecosystem from each other and thus fragmenting wildlife habitats.

From the above descriptions, the common features of roadway networks and stream systems should be apparent. Both are long, linear features of the landscape, and the transportation of materials and organisms is fundamental to their function. The function of both systems is critically dependent on connectivity across the landscape.

To maintain the riparian ecosystem of a stream, organisms need unhindered access to a variety of habitats found naturally along the hydrologic network. Aquatic species must be able to access food sources and safe havens that are dependent on their life stage. Young organisms need protection from predators; mature organisms need amenable spawning grounds. Organisms need to be able to escape temporary changes in conditions caused by natural or manmade processes that render an area uninhabitable (e.g., siltation or changes in temperature). Groups of organisms are highly vulnerable if they are isolated in one area because the population becomes susceptible to inbreeding, localized extinctions, and disease due to overcrowding.

Different types of organisms move through the riparian ecosystem in different ways. Strong migratory fish can navigate turbulent and rapidly flowing reaches with quick bursts of speed but rely on still-water pools to rest and regain their strength. Resident fish are often weak swimmers unable to overcome even minor obstacles. Turtles and salamanders rely on continuity of the banks and channel substrate for successful movement. Other aquatic “non-swimmer” organisms depend on symbiotic relationships with the “swimmers” to move through the system.

Thus, the ability for wildlife to move is essential for many reasons, including:

- Access to feeding areas (needs vary not only among species, but with various life-stages within species);

- Access to shelter and to refuge from predators (needs vary not only among species, but with various life-stages within species);
- Access to cold water habitats (aquatic organisms are often sensitive to temperature);
- Access to areas with conditions suitable for spawning and breeding;
- Access to allow populations to exploit new habitats and to sustain natural population growth or prevent population decline;
- Interaction with other groups of individuals to maintain genetically healthy populations.

Obstruction of movement therefore can have adverse consequences not only to individual members of a species, but also to larger populations of species and assemblages of species.

Traditionally, road designers have addressed the key elements that provide for passage of people and materials along the roadway at stream crossings. The designers have also addressed the conveyance of flows along the streams at these crossings. To some degree, the movement of sediment and natural debris has been traditionally addressed in design only insofar as these materials affect structural integrity or flow capacity, but not with conscientious regard for the role these materials play in the ecological condition of the stream system. The movement of wildlife through these crossings is not well understood (other than for a limited number of fish species at various life-stages) and has usually received little attention in the design of culverts and bridges.

As a consequence of the design of crossings to meet primarily structural and hydraulic requirements, many crossings have become obstructions to wildlife movement. Hydraulically efficient structures can create conditions that interfere with the hydraulic and geologic processes (e.g., erosion and deposition of sediment) that occur in natural channels. Engineered structures frequently create flow depths and velocities that aquatic organisms cannot negotiate. Hydraulic energy transitions at the inlets and outlets of culverts result in impassable hydraulic conditions for organisms, and also in physical alterations to the channel, which affect the ability of organisms to move freely through the system. For example, the dissipation of energy associated with high velocities at the outlet of a culvert commonly results not only in scour pool formation, but also in channel degradation for some distance downstream. This can result in a condition known as “perching,” depicted in Figure 2-1.

Over time, a drop develops from the bottom of the culvert to the low-flow water surface of the downstream pool. Such drops limit the movement of those organisms that cannot negotiate the “jump” from the pool to the barrel of the culvert.

Figure 2-2 depicts some of the following conditions at culverts (as well as some bridges) that result in obstruction of the movement of wildlife:

- Outlet drops (perching), which pose structural barriers to passage of many aquatic organisms;
- Drops at culvert inlets, either as a result of initial installation or subsequent channel alteration, which also pose structural or hydraulic barriers to passage;



**Figure 2-1. “Perched” Culverts Fragment Aquatic Habitat.**

- Inadequate flow depths under ordinary low flow conditions (not due to drought), which do not provide minimum depths essential for aquatic organisms to move;
- High velocities under a variety of flow conditions, ranging from low flows to seasonal high flows (especially flows occurring during periods of migration). At prevailing velocities during the period when they need to move, organisms must have sufficient swimming ability and endurance to move upstream;
- Scouring and erosion;
- Clogging by natural or urban debris;
- Pond formation upstream of culverts as a result of clogging, sediment deposition, or inadequate culvert size;
- Unnatural bed materials that either physically interfere with passage, or affect the movement behavior of organisms even if they are physically capable of negotiating the passage. “Unnatural bed materials” may include synthetic materials, such as paved channels or concrete rubble, but can also include rock riprap or other “natural” lining materials that substantially differ in size and gradation from the nearby natural streambed; and

- The lack of sufficient “dry bank” under prevailing flow conditions. The absence of banks or shallow stream margins inhibits the terrestrial movement of animals that do not use the water column or streambed material (stream substrate) for travel.

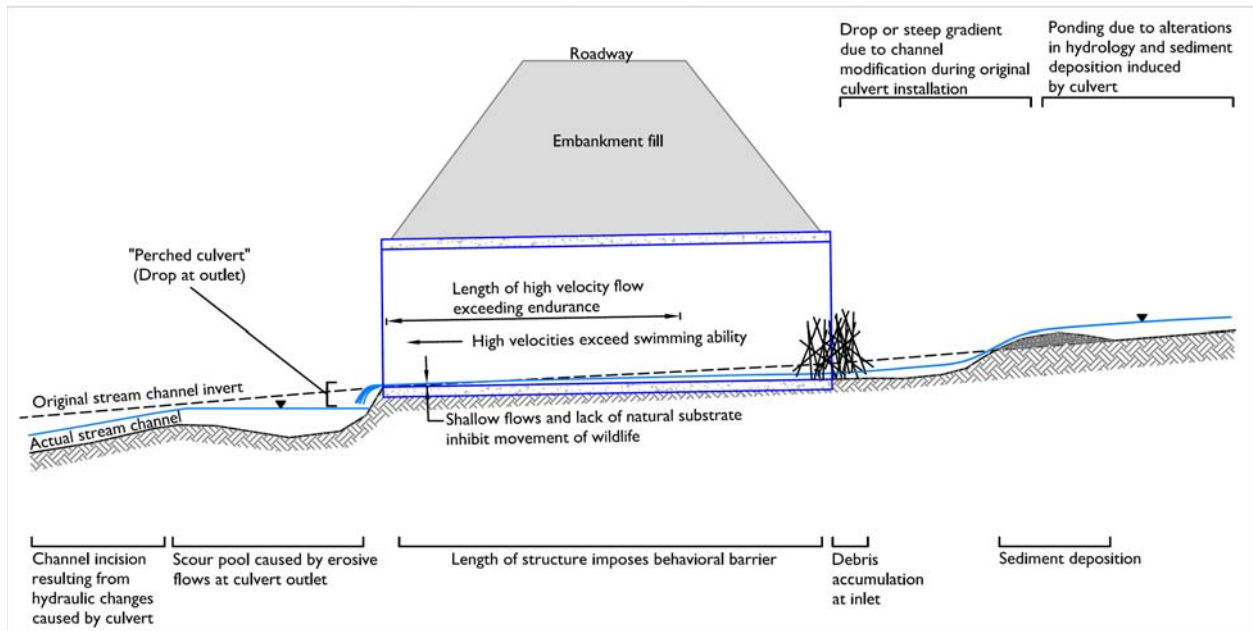

**Figure 2-2. Conditions Affecting Wildlife Passage at Culverts**

Adequate accommodation of wildlife passage calls for a stream crossing design approach that provides hydraulic and substrate conditions throughout the structure, to prevent or overcome the above conditions. Ideally, a bridge or culvert stream crossing should safely carry traffic over a structurally sound, hydraulically adequate structure, and in addition be essentially “transparent” to wildlife. The Massachusetts River and Stream Crossing Standards were developed to meet this objective. The standards described in this chapter derive from a “Stream Simulation” design approach that addresses the potential impeding conditions by providing a continuous natural or “near-natural” channel within the crossing, maintaining connectivity with the existing stream system.

The following references provide additional information on the importance of stream continuity, the passage problems associated with stream crossing structures, and the rationale for designing stream crossings for wildlife movement:

- Massachusetts Division of Ecological Restoration, Department of Fish & Game’s *Massachusetts Stream Crossings Handbook* (Department of Fish and Game, June 2005, available at the web-site:
  - <http://www.mass.gov/dfwele/der/freshwater4/rivercontinuity/guidancedoc.htm>
- University of Massachusetts River and Stream Continuity Project web-site:
  - <http://www.streamcontinuity.org/index.htm>

## 2.2 Evaluating Existing Crossings Relative to Wildlife Passage

Many of MassDOT's projects involve improvements to or reconstruction of existing roads and bridges. For reconstruction of existing stream crossings, the selection of type of structure will depend, in part, on the degree to which the existing structure accommodates the movement of aquatic and non-aquatic wildlife. If an existing structure offers a reasonable degree of passage, then the options for the improvement project may include "in-kind" replacement. If the existing structure is a barrier to aquatic wildlife passage, then alternatives for replacement should include crossing structure designs or other design measures that would mitigate for this condition.

The assessment of an existing structure regarding its capacity to permit wildlife passage may require consultation with persons with expertise in aquatic and terrestrial passage, including early coordination with Massachusetts Department of Fish and Game and other affected resource agencies. Current literature also includes various criteria and methodologies for assessing whether conditions at culverts and bridges permit wildlife movement.

In conjunction with the issuance of the ACOE Comprehensive Permit for Bridges (CPB), MassDOT has compiled a simplified rating chart, based on a scoring system developed by the Massachusetts River and Stream Continuity Project. The MassDOT rating chart scores an existing or proposed structure using the information compiled from a field evaluation worksheet, also developed by the Massachusetts River and Stream Continuity Project. The field evaluation procedure has been applied to existing crossings in several New England states for the assessment of crossings and the evaluation of stream networks for habitat continuity. Appendix B includes the MassDOT rating chart, as well as a copy of the 2010 version of the Stream Continuity Project field evaluation work sheet and instructions.<sup>4</sup>

Project planners and designers may use this field evaluation and scoring methodology to assist in identifying the degree of passage afforded by an existing structure. Planners and designers may also apply this scoring methodology to proposed designs of replacement structures.

The procedure consists of the following:

- Step 1. Complete the field evaluation form, following the instructions prepared by the Stream Continuity Project.
- Step 2. Using the completed worksheet, use the "MassDOT Stream Crossing Structures Rating Chart" to develop a numerical rating of the culvert or bridge, on a scale of 0 to 10.
- Step 3. Using the Rating compiled in Steps 1 and 2 determine the passage classification of the structure from Table 2-1.

---

<sup>4</sup> The Massachusetts River and Stream Continuity Partnership revised the field evaluation worksheet and instructions in 2010. It also is developing an updated scoring system that is unpublished as of the date of this Handbook. The MassDOT rating system has been incorporated into the Comprehensive Permit for Bridges (term expires in 2015). MassDOT will consider incorporating the modified scoring system into future revisions of this Handbook and future renewals (if applicable) of the CPB.

Using the classification obtained from the above procedure, the designer can determine whether the existing structure is a barrier, allows for aquatic passage only, or allows for wildlife passage. The designer can then use this information to address the design criteria identified in Chapter 3 of this document.

**Table 2-1. Passage Classification for Existing Stream Crossing Structures<sup>5</sup>**

Rating Score	Passage Classification	Remarks
0 to 1	Severe Barrier	The structure is considered a barrier to most aquatic and terrestrial wildlife.
2	Moderate Barrier	The structure may provide some passage for aquatic wildlife, and is likely a barrier to terrestrial wildlife. Further investigation is required to determine the extent to which it provides aquatic passage.
3 to 5	Minor Barrier	The structure is likely to provide aquatic wildlife passage, but has limited capacity for non-aquatic species.
6 to 8	Meets General Standards	The structure provides aquatic and terrestrial passage consistent with the General Standards of the Massachusetts River and Stream Crossing Standards. <sup>6</sup>
9 to 10	Meets Optimum Standards	The structure provides aquatic and terrestrial passage consistent with the Optimum Standards of the Massachusetts River and Stream Crossing Standards.

Note that if the crossing structure rates as a “moderate barrier,” further investigation is needed to determine whether the culvert allows sufficient passage of aquatic organisms. Such investigation might include (but not necessarily be limited to) hydraulic evaluation relative to passage criteria for individual species of concern (such as migratory fish species). Coordination with affected resource agencies may also be required. MassDOT recommends coordination with the Department’s Environmental Section to determine the scope of further investigations warranted based on the initial field evaluation.

---

<sup>5</sup> See previous Footnote regarding future revisions of this scoring and classification system.

<sup>6</sup> Structures with a Rating Score of “8” may meet optimum standards where reduced openness (>1.64 feet (0.5 meter)) and height (>4 feet (1.2 meters)) requirements are applicable.

Designers may consider other tools or methodology available in the literature to assist in evaluating existing crossing structures for their ability to accommodate fish and aquatic organisms. For example, the USDA Forest Service has developed a software program called “FishXing” (pronounced “fish crossing”) for evaluating culvert hydraulics relative to fish passage. However, this model has limitations for use in Massachusetts, because it requires detailed information on stream hydrology that may not be readily available, and the current software does not include data for many of the native fish species found in New England.

If designers propose the use of FishXing, other models, or alternative methods, they should consult with fisheries biologists on the applicability of those methods, the species that should be considered, and the swimming speeds and leaping capabilities that should be used in the evaluation. Also, note that this software focuses on fish passage, and does not necessarily address the accommodation of the full range of wildlife species considered in this design guidance.



## 2.3 Introduction to the Massachusetts River and Stream Crossing Standards

The Massachusetts River and Stream Crossing Standards respond to concerns that bridges and culverts designed according to traditional hydraulic and structural criteria often result in the disturbance of habitat connectivity and hindrance not only to fish passage, but also to the passage of other aquatic and terrestrial fauna along the riparian corridor. The standards seek to achieve fish and other aquatic organism passage, river/stream habitat continuity, and terrestrial wildlife passage at stream crossings. These objectives address the movement of organisms across the full range of species and life-stages found along natural stream systems.

The River and Stream Continuity Partnership, which includes the University of Massachusetts Amherst, Massachusetts Division of Ecological Restoration, Department of Fish and Game (Riverways Program), and The Nature Conservancy, developed the standards. An initial document was issued in August of 2004. Subsequently, the document was revised and updated, and issued as the March 1, 2006 version included in Appendix A of this handbook.<sup>7</sup>

The Crossing Standards are generally based on an approach to stream crossing design referred to as “Stream Simulation.” The Stream Simulation design approach endeavors to create conditions within a culvert or bridge opening that replicate the conditions found in the adjacent stream. As a result, the channel through the crossing would be expected to maintain the diversity of structure and materials inherent in the existing stream system, which in turn permits the movement of resident and migratory species over a wide range of flow conditions in the stream.

This design approach provides for the development of a natural streambed (or “substrate”) within the crossing structure, which is continuous with the upstream and downstream channel. The approach also provides a corresponding width and height of opening to ensure the long-term viability of this substrate, given the full range of hydraulic conditions anticipated for the structure. Implicit in this design approach is the development of a crossing that has the following characteristics:

- It does not constrict flows as they enter the structure, and does not result in significant hydraulic drops or jumps upstream of, within, or immediately downstream from the crossing;
- It maintains velocities and flow depths under a variety of flow conditions at values similar to those occurring in the adjacent natural channel;
- It provides bed materials of the type and texture occurring in the adjacent streambed, allowing for similar passage conditions for organisms above, on, and within the substrate; and

---

<sup>7</sup>At the time of publishing of this Handbook, the Massachusetts River and Stream Continuity Partnership is revising the River and Stream Crossing Standards. MassDOT anticipates a future update of this Handbook will incorporate changes corresponding to those revised Standards. Designers should consult the US Army Corps of Engineers, New England District website [<http://www.nae.usace.army.mil/reg/>] under “Stream and River Continuity” for the most current version of the Standards applicable to the Massachusetts General Permit.

- It provides for terrestrial passage of wildlife during “normal” flow conditions (that is, those conditions when the stream is confined within its bankfull channel width).

The River and Stream Crossing Standards outline specific requirements to introduce this stream simulation approach into the design of bridges and culverts at new crossings and at locations where existing structures will be replaced. In addition, the Crossing Standards provide for an “openness” of the structure that would be conducive to the terrestrial movement of wildlife along the immediate stream corridor through the structure. Figure 2-3 presents a schematic representation of a culvert that incorporates a “stream simulation” design.

Construct channel within culvert to replicate conditions of “reference stream”

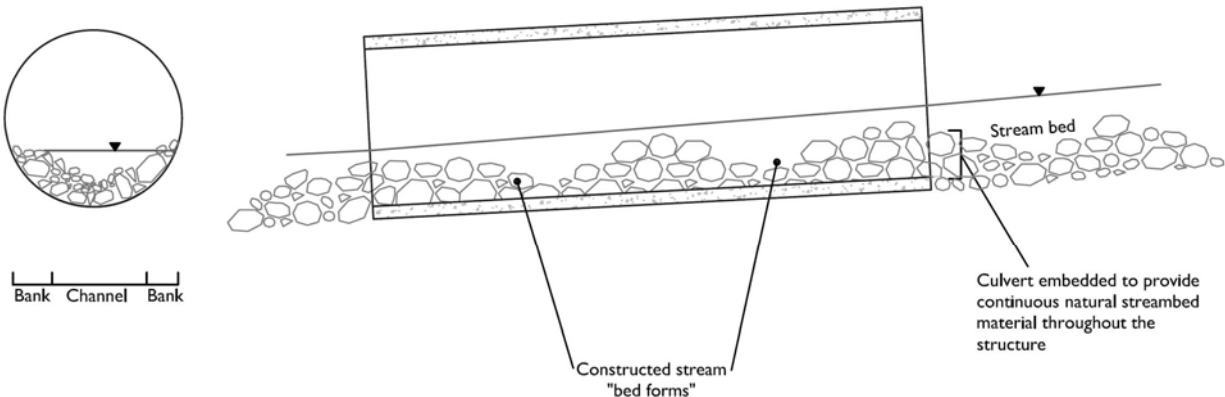

**Figure 2-3. Stream Simulation Culvert Design**

Table 2-2 presents a summary of the standards included in the Massachusetts River and Stream Crossing Standards. Appendix A contains a copy of the Standards.

The standards are organized into three major sub-topics, as follows:

1. Design Standards for New Crossings.
2. Design Standards for Culvert Replacement.
3. Construction Best Management Practices.

The Design Standards for New Crossings include “General Standards” and “Optimum Standards”. General Standards apply to fish bearing streams and rivers where the goal is to provide fish passage, stream continuity, and some wildlife passage. The General Standards are anticipated to apply to most stream crossings.

Table 2-2. Summary of the Massachusetts River and Stream Crossing Standards

	GOALS	APPLICATION	STANDARDS
<b>New Structures</b>	<p>To provide:</p> <ul style="list-style-type: none"> <li>■ Fish passage</li> <li>■ River/stream continuity</li> <li>■ Some wildlife passage</li> </ul> <p><b>General Standards</b></p>	<p>Permanent stream crossings on fish bearing streams<sup>1</sup></p>	<ul style="list-style-type: none"> <li>■ Bridges are generally preferred, but well designed culverts and open-bottom arches may be appropriate</li> <li>■ If the structure is a culvert, then it should be embedded to a depth of:               <ul style="list-style-type: none"> <li>- ≥ 2 feet for box culverts and other culverts with smooth internal walls</li> <li>- ≥ 1 foot for corrugated pipe arches</li> <li>- ≥ 1 foot and at least 25 % for corrugated round pipe culverts</li> </ul> </li> <li>■ The structure must span the channel width by a minimum of 1.2 times the bankfull width</li> <li>■ The structure must contain natural bottom substrate</li> <li>■ The structure must be designed with appropriate bed forms and streambed characteristics so that water depths and velocities are comparable to those found in the natural channel at a variety of flows</li> <li>■ The openness ratio must be ≥ 0.82 feet (0.25 meters). See Note 2.</li> <li>■ Use bridge spans</li> <li>■ The structure must span the streambed and banks with a minimum opening of at least 1.2 times the bankfull width.</li> <li>■ The structure must contain natural bottom substrate</li> <li>■ The structure must be designed with appropriate bed forms and streambed characteristics so that water depths and velocities are comparable to those found in the natural channel at a variety of flows</li> <li>■ Maintain a minimum height of 6 feet (1.83 meters) and an openness ratio of ≥ 2.46 feet (0.75 meter) if conditions are present that significantly inhibit wildlife passage. See Note 2.</li> <li>■ If conditions do not significantly inhibit wildlife passage, maintain a minimum height of 4 feet (1.22 meters) and an openness ratio of ≥ 1.64 feet (0.5 meter). See Note 2.</li> </ul>
	<p>To provide:</p> <ul style="list-style-type: none"> <li>■ Fish passage</li> <li>■ River/stream continuity</li> <li>■ Wildlife passage</li> </ul> <p><b>Optimum Standards</b></p>	<p>Permanent stream crossings on fish bearing streams<sup>1</sup> in areas of regional significance for their contribution to landscape level connectedness or river/stream ecosystems that provide for important aquatic habitat for rare or endangered species</p>	
<b>Replacement Structures</b>	<p>To improve:</p> <ul style="list-style-type: none"> <li>■ Fish passage</li> <li>■ River/stream continuity</li> <li>■ Wildlife passage</li> </ul> <p><b>Design Standards for Culvert Replacement</b></p>	<p>Existing permanent stream crossings on fish bearing streams<sup>1</sup></p>	<ul style="list-style-type: none"> <li>■ Whenever possible, replacement culverts should meet the design guidelines for either General Standards or Optimal Standards</li> <li>■ If it is not possible or practical to meet all of the general or optimal standards, replacement crossings should be designed to:               <ul style="list-style-type: none"> <li>- meet the General Standards for crossing width (1.2 x bankfull width)</li> <li>- meet other General Standards to the extent practical</li> <li>- avoid or mitigate the following:                   <ul style="list-style-type: none"> <li>■ Inlet drops, outlet drops, flow contractions and turbulence, tailwater scour, pools, and physical barriers to fish passage</li> </ul> </li> <li>■ Use scour analyses, assessment of longitudinal profiles, and other methods to design the structure with appropriate grade controls to ensure that the replacement will not destabilize the river/stream</li> <li>■ To the extent practical, conduct stream restoration as needed to restore river/stream continuity and eliminate barriers to aquatic organism movement</li> <li>■ Avoid using high density polyethylene (HDPE) or plastic pipes</li> </ul> </li> </ul>
<b>All structures</b>	<p>To minimize disturbance to the water body during construction</p> <p><b>Construction Best Management Practices</b></p>	<p>Applicable to all work affecting the conditions of a fish bearing stream<sup>1</sup></p>	<p><b>CONSTRUCTION GUIDANCE</b></p> <p>Construction best management practices for minimizing construction impacts address the following topics:</p> <ul style="list-style-type: none"> <li>■ Dewatering</li> <li>■ Stormwater management, erosion, and sediment control</li> <li>■ Pollution control</li> <li>■ Constructing stream bed and banks within structures</li> <li>■ Soil stabilization and re-vegetation</li> <li>■ Monitoring</li> </ul>

1. Fish bearing streams include rivers and streams that support one or more species of fish, including those portions of intermittent streams that are used seasonally by fish.

These standards are also warranted where fish are not present, but where protection of salmonanders or other local wildlife species is desired.

2. The openness ratio is defined as the cross sectional area of the clear opening of the crossing (measured in square meters) divided by the crossing length (in meters).



Optimum Standards are intended to apply to streams in areas of particular statewide or regional significance. The Optimum Standards provide for a greater degree of wildlife passage, and a stronger emphasis on the use of bridge spans for crossings.

Key elements of the standards (“General” and “Optimum”) for new and replacement crossings include the following:

- A strong preference for bridge spans (which could include “bottomless culvert” structures). In the case of General Standards, well-designed embedded culverts, while not preferred, may be appropriate;
- Requirement that each structure span the streambed and banks (1.2 times the river/stream bankfull width; see further explanation of this parameter below);
- Provision of natural substrate within the structure (either by preserving the streambed, or by countersinking the structure and development of streambed material within the structure);
- Design of constructed streambed material to result in velocity conditions comparable to those in the natural channel under a variety of flows; and
- Design of the structure cross-section to provide a minimum “openness” to facilitate wildlife passage. Calculation of “openness” is discussed below.

In addition to these requirements, the Massachusetts Stream Crossing Standards also address construction Best Management Practices, to address potential impacts to streams during the installation of new and replacement crossings. Designers should include consideration of water handling methods, erosion control, and sediment control as an integral component of the selection and design of stream crossing structures.

It is important to note that the Massachusetts Stream Crossing Standards prescribe minimum requirements for bridges and culverts for addressing habitat continuity, but the standards do not include detailed design guidance for achieving these requirements. For example, the standards specify the continuity of substrate materials within crossing structures, but do not provide specific guidance on the design of this material for long-term viability. The designer of the stream crossing must seek guidance from other technical resources to develop a bridge or culvert design that will meet hydraulic and structural standards required for highways, while accommodating the fluvial processes that affect the morphology and dynamic stability of streambeds. Later chapters of this handbook discuss design approaches and technical resources for accomplishing such design.

## 2.4 Determining the Bankfull Width of a River or Stream

The bankfull width of a stream comprises a key parameter in the design of a stream crossing for habitat continuity. The River and Stream Crossing Standards indicate that the width of stream crossing structure opening should be at least 1.2 times the “bankfull width” of the stream channel. This parameter should be determined by evaluating the stream in the field, which requires a basic understanding of stream geomorphology. In some cases, as discussed below, field determination may not be feasible because of urban impacts or other channel disturbance, in which case alternative methods for estimating bankfull width may be necessary. Engineers or scientists with training and experience in stream assessment should perform this fieldwork.

A recommended reference for field methodology is the USDA Forest Service publication *Stream Channel Reference Sites: An Illustrated Guide to Field Technique* (Harrelson, et.al., 1994). Various public and private organizations offer training in fluvial geomorphology and in-the-field determination of bankfull stage and width. The US Forest Service also offers a series of learning modules on four CD-ROM disks, “A Guide to Identification of Bankfull Stage in the Northeastern United States” (General Technical Report RMRS-GTR-133-CD). This electronic publication and other training videos for the determination of bankfull parameters are available through the following contact:

USDA Forest Service  
Stream Systems Technology Center  
Rocky Mountain Research Station.  
2150 Centre Ave, Bldg. A, Suite 368,  
Fort Collins, CO 80526.  
(970) 295-5983

<http://www.stream.fs.fed.us/publications/videos.html>

The bankfull width of a stream is the top width of the water surface in a channel flowing at “bankfull discharge”. Bankfull discharge is thought of as the “channel forming” or “channel maintaining” flow, or as a surrogate parameter for the range of flows that control the form of a channel. It corresponds closely to “effective discharge” - the flow that transports the largest amount of sediment in the long term under current climatic conditions. Bankfull discharge is defined as that flow occurring when stream water just begins to overflow onto the active floodplain adjacent to the channel. The active floodplain is generally a flat area adjacent to the channel constructed by the stream and overflowed by the stream. The recurrence interval for such flows is typically about 1.5 years, but can vary widely. “Bankfull stage” is the elevation of the water surface at the point where this overflow onto the floodplain occurs. See the USDA Forest Service reference recommended above for further discussion of bankfull discharge and its field indicators. Figure 2-4 illustrates bankfull width and stage for a typical stream.

A variety of indicators can help in determining the bankfull stage and corresponding bankfull width of a stream. The primary indicator is the flat, depositional surface of the active floodplain, where this feature is

prominent. However, in areas where the floodplain is poorly defined or absent, other indicators may be used to estimate bankfull stage or corroborate its elevation, including the following:<sup>8</sup>

- Slope or topographic breaks along the bank;
- Height of depositional features (especially the tops of the point bars, which define the lowest possible level for bankfull stage);
- Change in vegetation (especially the lower limit of perennial species);
- Change in the particle size of bank material, such as the boundary between coarse cobble or gravel with fine-grained sand or silt;
- Undercuts in the bank, which usually reach an interior elevation slightly below bankfull stage; and
- Stain lines or the lower extent of lichens on boulders.

Note that while a number of these parameters can help corroborate the determination of bankfull stage, the best indicator is the depositional surface of the floodplain. On New England Streams, it is not unusual for most of the other indicators, including some mature trees, to be located on the bank at a lower elevation than bankfull stage.

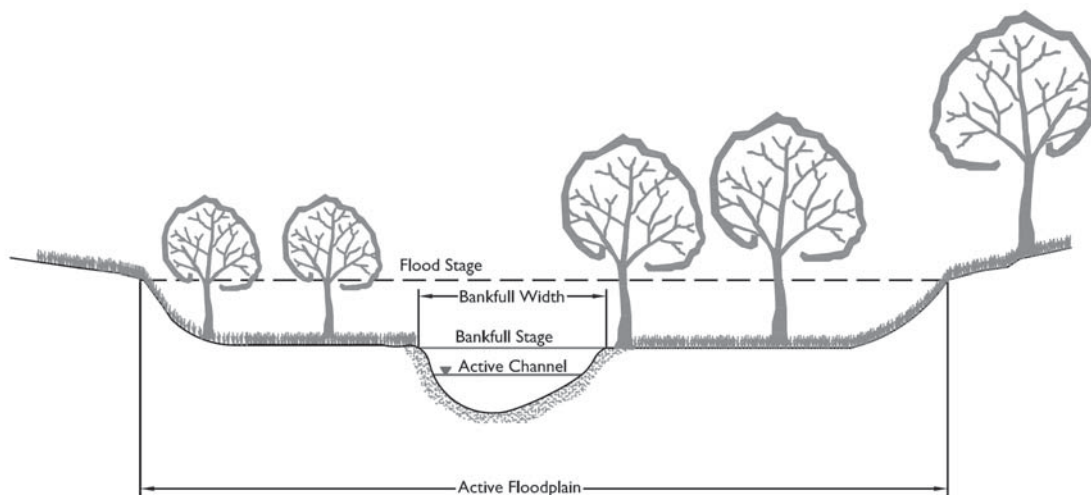

**Figure 2-4. Bankfull Channel Width**

<sup>8</sup> Harrelson, et.al., 1994, p33.

While field identification is the preferred method for estimating the bankfull stage of a stream, this method relies on the assumption that the observed channel represents natural, quasi-equilibrium conditions, and is not in the process of significant change. In watersheds with changing land use, in streams subject to regulation by upstream impoundments, or in streams subject to recent hydrologic disturbance by extreme flood events or other natural occurrences, such equilibrium conditions may not exist. In these cases, alternative methods may be required to estimate bankfull stage and width. In watersheds undergoing extensive land development, bankfull width may even be indeterminate.

Using a “reference stream” is an alternative where the subject stream has been temporarily disturbed or where the disturbance is localized and not due to extensive watershed disturbance. This method comprises the identification of a comparable, undisturbed nearby stream, with similar geologic and hydrologic characteristics. Field data from one or more such reference streams can be obtained to estimate anticipated conditions at the subject stream crossing.

Where watershed disturbance precludes the use of field data obtained from the subject stream or a suitable reference, the designer may need to more roughly assess bankfull discharge by comparing estimates of stream conveyance capacity to flood discharges with recurrence intervals between one and five years.

Published data on regional relationships of bankfull width/depth/discharge to watershed size (and other characteristics) can also be useful in corroborating estimates of bankfull discharge from other methods.

The U.S. Geological Survey (USGS) has developed regression equations for estimating bankfull-channel geometry and discharge for streams in the Northeastern United States. The equations are useful for initial planning analysis and conceptual design. Field investigators may also use the estimates obtained from these equations to assist in verification of field assessment of bankfull parameters. Table 2-3 presents the USGS equations describing the relationship of bankfull width, stage, and discharge to watershed area.

Designers should not consider the flood flow capacity estimates or the use of regression equations a substitute for an on-the-ground evaluation of bankfull width, where the physical evidence allows field identification. Designers should obtain a properly executed field assessment of bankfull width to use as a basis for selecting and designing structures as discussed in this Handbook. Further information about documenting this data is included in Chapter 6 of the Handbook.



**Table 2-3. Equations for Estimating Bankfull-Channel Geometry and Discharge for Streams in the Northeastern United States**

(Source: Bent, 2006)

<b>Bankfull Channel Parameter</b>	<b>Regression Equation<sup>9</sup></b>
Bankfull stream width (ft)	$W_{BF} = 13.2635[\text{drainage area (mi}^2)]^{0.4459}$
Bankfull stream mean depth (ft)	$D_{BF\text{-mean}} = 0.9951[\text{drainage area (mi}^2)]^{0.3012}$
Bankfull stream cross-sectional area in (ft <sup>2</sup> )	$A_{BF} = 12.8552[\text{drainage area(mi}^2)]^{0.7537}$
Bankfull discharge (ft <sup>3</sup> /s)	$Q_{BF} = 40.9545[\text{drainage area (mi}^2)]^{0.8448}$

---

<sup>9</sup> These equations are applicable for streams with drainage areas ranging from 0.20 to 332 square miles. At the time of preparation of this document, the USGS is developing regression equations specific to streams in Massachusetts, and the document presenting these equations is under agency review. For watersheds with parameters falling within the statistical limits of the new equations, the Massachusetts equations should be used instead of those listed in Table 2-2, when the USGS publishes them.

## 2.5 Determining “Openness”

The Massachusetts River and Stream Crossing Standards specify minimum openness values for stream crossing structures. The “openness” is determined by dividing the cross sectional flow area of the structure by the length of the crossing (measured in the direction of stream flow).<sup>10</sup> Note that the embedded portion of the structure is not included in the cross-sectional area computation.

The “General Standards” require an openness value of 0.82 feet (0.25 meters). For example, a structure with a length (measured in the direction of stream flow) of 40 feet (12.2 meters) would require an open area of 32.8 square feet (3.05 square meters). This area must be provided above the streambed material within the structure. Figure 2-5 illustrates the openness computation for several types of structures.

The “Optimum Standards” require a greater openness value, and a minimum clear height of opening above the streambed. An openness value of 2.46 feet (0.75 meters) and clear height of 6 feet (1.8 meters) are required where conditions significantly inhibit wildlife passage (high traffic volumes, steep embankments, fencing, Jersey barriers within the roadway median, or other physical obstructions). If such conditions are not present, then the Optimum Standards call for an openness value of 1.64 feet (0.5 meters) and clear height of 4 feet (1.2 meters).

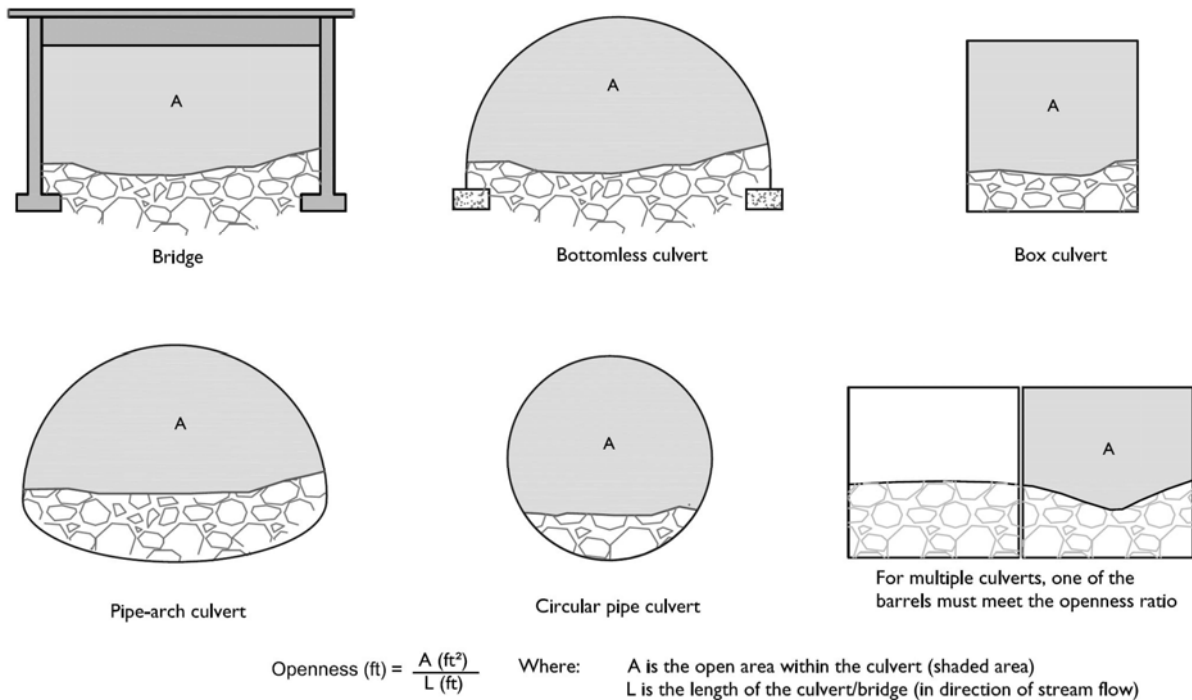

**Figure 2-5. Openness for Culverts and Bridges**

<sup>10</sup> Note that in the Massachusetts Stream Crossing Standards the openness is presented in metric units; conversion to English units is provided in this guidance document.

## 2.6 Thresholds for Optimum Standards

The Massachusetts River and Stream Crossing Standards describe “Optimum Standards” where the goal is to provide fish passage, stream continuity, and wildlife passage. As stated by the standards,

*“Where stream crossings occur or are planned in areas of particular statewide or regional significance for their contribution to landscape level connectedness or river/stream ecosystems that provide important aquatic habitat for rare or endangered species, optimum standards should be applied in order to maintain river/stream continuity and facilitate passage for fish and wildlife.”*

According to the standards, areas of particular significance for their contribution to landscape level connectedness include, but are not limited to, stream corridors linking areas of significant habitat (>250 acres) in three or more towns. Important aquatic habitat for rare or endangered species includes, but is not limited to, river and stream segments identified by the Natural Heritage and Endangered Species Program (NHESP) through regulatory review or through NHESP’s “Biomap2” project.

The US Army Corps of Engineers (USACE) Massachusetts General Permit (MGP) and the Massachusetts 401 Water Quality Certification Regulations do not currently reference the “Optimum Standards” nor require their specific application (see discussion of Regulatory Context below). However, MassDOT anticipates that the Optimum Standards are likely to be considered by regulatory personnel for guidance in areas where habitats are considered significant and where habitats would support rare and endangered species.

Therefore, the stream-crossing designer should review the regional setting of the project relative to habitats supportive of rare and endangered species, as well as areas where stream corridors connect other habitats considered significant by NHESP. The occurrence of such habitats should then be considered in the design of the stream crossing. The designer should consult the following references regarding potential habitats that could warrant consideration of “Optimum Standards”:

- Massachusetts Natural Heritage Atlas, maps for *Estimated Habitats of Rare Wildlife and Certified Vernal Pools* and *Priority Habitats of Rare Species*; refer to the following web page: [http://.mass.gov/dfwele/dfw/nhesp/regulatory\\_review/priority\\_habitat/online\\_viewer.htm](http://.mass.gov/dfwele/dfw/nhesp/regulatory_review/priority_habitat/online_viewer.htm)
- NHESP *BioMap2* interactive map and supporting information, at the web page: [http://www.mass.gov/dfwele/dfw/nhesp/land\\_protection/biomap/biomap\\_home.htm](http://www.mass.gov/dfwele/dfw/nhesp/land_protection/biomap/biomap_home.htm)
- Designated Wild and Scenic Rivers in Massachusetts <http://www.rivers.gov/wildriverslist.html#ma>
- Massachusetts Stream Continuity Project, Mapping of High Quality Streams [http://www.streamcontinuity.org/assessing\\_crossing\\_structures/prioritizing\\_streams.htm](http://www.streamcontinuity.org/assessing_crossing_structures/prioritizing_streams.htm)

The Massachusetts River and Stream Continuity Project web-site listed above identifies high quality streams using GIS data based on the other listed sources of information and related data. MassDOT recommends contacting this project, checking its web-page at <http://www.streamcontinuity.org/index.htm>, and also contacting the Massachusetts Department of Fish and Game Division of Ecological Restoration, Riverways Program, to obtain the most recent information on the mapping and classification of Massachusetts streams. MassDOT also recommends consulting these



programs for information they have compiled regarding prioritization of streams and crossings for improvement of stream continuity.

The “Linking Landscapes for Massachusetts Wildlife” project is an interagency initiative by MassDOT, MassWildlife, and UMass Amherst to identify and categorize site-specific wildlife roadway mortality “hotspots,” with an emphasis on herpetofauna. Designers should consult with MassDOT, MassWildlife, or UMass Amherst project coordinators to determine whether a site-specific wildlife roadway mortality “hotspot” exists at the project site. The Critical Linkages project currently underway at UMass Amherst will eventually provide maps of areas of statewide and regional importance for landscape-scale connectivity.

Designers should also consult with regulatory agencies early in the project development phase, to discuss applicable permitting requirements, and to identify relevant habitat conditions at the project site, within the watershed of the stream crossing, and within the general region of the project.

## 2.7 Regulatory Context

Relative to the accommodation of wildlife at stream crossings, the regulations of primary concern include the following:

Federal Regulations:

- Section 10 of the Rivers and Harbors Act of 1899; and
- Section 404 of the Clean Water Act (CWA).

Massachusetts Regulations:

- 314 CMR 9.00: 401 Water Quality Certification for Discharge of Dredged or Fill Material, Dredging, and Dredged Material Disposal in Waters of the United States Within the Commonwealth (401 Regulations); and
- 310 CMR 10.00: Wetlands Protection Act Regulations.

Federal requirements applicable to the provision of wildlife accommodation at stream crossings are generally specified in the US Army Corps of Engineers (USACE) Massachusetts General Permit (MGP), and also in the USACE Massachusetts Department of Transportation Comprehensive Permit for Bridges (CPB), an individual programmatic permit issued for MassDOT bridge replacement/reconstruction activities. Appendix C contains a copy of the MGP. Appendix D includes a copy of the CPB.

Table 2-4 (at the end of this chapter) presents guidance for determining whether a particular bridge project is eligible for consideration under the MGP Category 1, MGP Category 2, or the CPB. Projects within USACE jurisdiction that do not fall into one of these categories would require application for a Section 404 Individual Permit from the Corps. MassDOT's recommended order of preference for the permit eligibility of a project is as follows:

1. Project is designed to be eligible under the CPB (document eligibility; provide Work Start Notification Form to the New England District, USACE).
2. Project is designed to be eligible as Category 1 (no application required) under the MGP (document eligibility; provide Category 1 Form to the New England District, USACE).
3. Project is designed to be eligible as Category 2 (application required) under the MGP (complete application to USACE).
4. Project is subject to a Section 404 Individual Permit (complete application to USACE).

Note that certain maintenance activities are not prohibited or subject to regulation under Section 404 of the CWA. Please refer to MGP's Appendix A Endnote 15, for a detailed discussion of how Corps regulations address "maintenance."

Massachusetts requirements applicable to crossings are set forth in the 401 Regulations, which cross-reference the Wetlands Protection Act Regulations. Appendix E includes a copy of the 401 Regulations.

The applicable federal and state permit requirements are briefly discussed in the following sections. Under both federal and state regulatory settings, early coordination between project designers and the affected regulatory and natural resource agencies is an important component of the crossing structure selection and design process. Early coordination will assist both design and regulatory personnel in identifying key issues that will need to be resolved in order to achieve regulatory compliance.

### **2.7.1 US Army Corps of Engineers Massachusetts General Permit**

The New England District of the U.S. Army Corps of Engineers (USACE) issued the Massachusetts General Permit (MGP) for the Commonwealth of Massachusetts in January 2010. The MGP expedites review of activities in waters of the United States that would have minimal individual and cumulative impacts on the aquatic environment within the Commonwealth of Massachusetts. The MGP covers activities in resource areas regulated by the USACE under Section 10 of the Rivers and Harbors Act of 1899, Section 404 of the Clean Water Act (CWA), and Section 103 of the Marine Protection, Research and Sanctuaries Act. The MGP establishes conditions for Category 1 (no application required) and Category 2 (application required) activities. A copy of the MGP is included as Appendix C of this guidance.

The MGP includes “General Condition 21. Stream Crossings and Work.” The terms of this condition are of particular note regarding the design of new and replacement stream crossings, and are quoted at length below:

*(a) All temporary and permanent crossings<sup>11</sup> of rivers, streams, brooks, etc. (hereon referred to as “streams”) shall be suitably culverted, bridged, or otherwise designed to i) withstand and prevent the restriction of high flows, and ii) not obstruct the movement of or not substantially disrupt the necessary life-cycle movements of those species of aquatic life indigenous to the waterbody, including those species that normally migrate through the area, beyond the actual duration of construction unless the activity’s primary purpose is to impound water.*

*(b) Any work that temporarily or permanently impacts upstream or downstream flood conditions or permanently impacts wetlands must be reviewed under Cat. 2. The “Massachusetts Dam Removal and the Wetland Regulations” may be used as a reference ....*

*[Note: (c)-(l) below only apply to Inland Waters and Wetlands...]*

*(c) For new stream crossings to qualify for Category 1:*

---

<sup>11</sup> The MGP does not apply to constructed drainage systems designed primarily for the conveyance of storm water or irrigation.

*i. These shall be designed and constructed<sup>12</sup> to conform to the General Standards contained in the version of the “Massachusetts River and Stream Crossing Standards” on our website....*

*ii. These shall be at least 5-feet wide at ground level to ensure that General Standard 3 is met for small streams.*

*iii. Spans<sup>13</sup> are required to avoid or cause minimal disruption to the streambed. Footings and abutments shall be landward of 1.2 times bankfull width (see General Standard 3 in (c) above). To the greatest extent practicable, work in the stream shall be minimized, and design and construction shall allow the streambed’s natural structure and integrity to remain intact. Any fill or excavation of the streambed below bankfull width other than footings, support pilings, and work specified in 21(h), 21(i), 21(l)ii and 21(l)iii, requires Category 2 review and, unless demonstrated otherwise, stream simulation as necessary to restore or establish substrate and banks in the span structure and work area to match the characteristics of the substrate and banks in the natural stream channel.<sup>13</sup>*

*(d) For replacement stream crossings:*

*i. These should be designed and constructed<sup>14</sup> to conform to the General Standards contained in the version of the “Massachusetts River and Stream Crossing Standards” on our website (see Appendix F of the MGP). This is recommended to ensure compliance with GC 21(a) and GC 21(b) above.*

*ii. Compliance with General Standards 2 and 4 is required to qualify for Category 1.*

*iii. Replacement crossings on the following high-quality stream segments are not eligible for Category 1: NHESP Living Water Cores, NHESP BioMap cores, ACECs, Anadromous Fish Runs, and Cold Water Fisheries. These are shown at:*

*[www.streamcontinuity.org/assessing\\_crossing\\_structures/prioritizing\\_streams.htm](http://www.streamcontinuity.org/assessing_crossing_structures/prioritizing_streams.htm)*

*(e) Culvert extensions do not qualify for Category 1 and must be reviewed by the Corps.*

*(f) For new stream crossings not eligible for Category 1, and for replacement crossings, applicants should use the least intrusive and environmentally damaging method to construct new and replacement stream crossings following this sequential minimization process: 1) Spans with no stream impacts, 2) Spans with stream impacts, and 3) Embedded culverts with stream simulation or low-slope design.*

---

<sup>12</sup> See Appendix F of the MGP for design and construction methodology

<sup>13</sup> For purposes of this GP, spans are bridges, 3-sided box culverts, open-bottom culverts or arches that span the stream with footings landward of bankfull width.

<sup>14</sup> See Appendix F of the MGP for design and construction methodology.

*(g) The permittee shall maintain the work authorized herein in good condition and in conformance with the terms and general conditions of this permit to facilitate aquatic life passage as stated in GC 21a. Culverts that develop “hanging” inlets or outlets, result in bed washout, or a stream that doesn’t match the characteristics of the substrate in the natural stream channel such as mobility, slope, stability, confinement will require maintenance or repair to comply with this GC.*

*(h) Paragraphs (b) - (g) above do not apply to:*

*i. Temporary spans. Temporary spans shall be removed within 180 days.*

*ii. Temporary stream crossings that aren’t spans (typically culverts). To qualify for Category 1, these must be designed in accordance with 1-6 below. Category 2 projects should follow 2-6 below:*

*1. Installed outside of the time of year (TOY) restrictions specified in GC 21(m) below and must be removed before the beginning of the TOY restriction of that same season. Those that will remain into the TOY restriction will require Category 2 review.*

*2. Placed on geotextile fabric or other material where practicable to ensure restoration to the original grade. Soil may not be used to construct or stabilize these structures and rock must be large enough to allow for easy removal without disrupting the streambed.*

*3. Designed and maintained to withstand and pass high flows. Water height should be no higher than the top of the culvert’s inlet. A minimum culvert diameter of two feet is required to pass debris. Culverts must be aligned to prevent bank erosion or streambed scour.*

*4. Equipped with energy dissipating devices installed downstream if necessary to prevent scour.*

*5. Designed and maintained to prevent soil from entering the waterbody.*

*6. Removed upon the completion of work. Impacts to the streambed or banks requires restoration to their original condition using stream simulation methods.<sup>15</sup>*

*(i) Temporary stream crossings (see h above) or cofferdams shall be used for equipment access across streams (see Appendix F of the MGP). Note: Areas of fill and/or cofferdams must be included in total waterway/ wetlands impacts to determine the review category in Appendix A (of the MGP).*

---

<sup>15</sup> See Appendix F of the MGP for design and construction methodology.



*(j) Maintenance and replacements of stream crossings. An existing stream crossing must be authorized and in compliance with all conditions of its authorization(s) to qualify for maintenance not subject to regulation. See Appendix A (of the MGP), Endnote 15.*

*(k) Projects using slip lining (retrofitting an existing culvert by inserting a smaller diameter pipe), plastic pipes and High Density Polyethylene (HDPE) pipes do not qualify for Category 1, either as new work or maintenance activities.*

*(l) For Category 1 work: i) No open trench excavation in flowing waters. ii) Management techniques such as temporary flume pipes, culverts, cofferdams, etc. must be used to maintain normal flows within the stream boundary's confines. iii) Water diversions may be used immediately up and downstream of the work footprint. See Appendix A (of the MGP), Endnote 4.*

*(m) For projects that otherwise meet the terms of Category 1, in-stream construction work shall not be conducted during the time of year (TOY) restrictions specified in the MA DMF document referenced in GC 24. For streams not indicated in this document, work may not be conducted from October 1 to June 30. Projects proposed during these TOY restrictions are ineligible for Category 1, regardless of the waterway and wetland fill and/or impact area.*

In addition to the requirements at stream crossings, the MGP also requires hydraulic and ecological connectivity at wetland crossings, as provided by General Condition 22:

*(a) All temporary and permanent crossings of wetlands shall be suitably culverted, bridged, or otherwise designed to:*

*i) Withstand and prevent the restriction of high flows,*

*ii) Not obstruct the movement of or not substantially disrupt the necessary life-cycle movements of those species of aquatic life indigenous to the wetland, including those species that normally migrate through the area, beyond the actual duration of construction unless the activity's primary purpose is to impound water.*

*(b) To qualify for Category 1, new and replacement wetland crossings that are permanent shall be culverted, spanned or bridged in such a manner as to preserve hydraulic and ecological connectivity, at its present level, between the wetlands on either side of the road. To meet this requirement, we recommend that culverts, spans or bridges be placed at least every 50 feet with an opening at least 2 feet high and 3 feet wide at ground level. Closed bottom culverts shall be embedded at least 6 inches with a natural bottom. In addition, see Appendix F for MassDEP's standards.*

*(c) In the case of non-compliance, the permittee shall take necessary measures to correct wetland damage due to lack of hydraulic connectivity.*

*(d) Any work that permanently impacts flooding, wetlands on either side of the wetland crossing, or wetland drainage from the upgradient side of the wetland crossing does not qualify for Category 1.*

In summary, the MGP requires temporary and permanent crossings (new or replacement) to maintain movement of indigenous aquatic life (Condition 21(a)), and establishes conditions for compliance for those projects falling within Category 1 or Category 2 review under this general permit.<sup>16</sup>

For projects subject to Corps jurisdiction that do not meet these conditions, the projects may require an individual permit. For MassDOT bridge projects meeting certain conditions, the projects may qualify for permitting under the Corps' Comprehensive Permit for Bridges (discussed below).

Designers should check the following website for the current posted version of the MGP, and consult with MassDOT's Environmental Section to confirm current permitting requirements under Section 404 of the CWA:

<http://www.nae.usace.army.mil/reg>

## 2.7.2 US Army Corps of Engineers Comprehensive Permit for Bridges

The New England District of the USACE issued the Massachusetts Department of Transportation Comprehensive Permit for Bridges (CPB) in August, 2010 with its term expiring July 31, 2015. The CPB is a programmatic permit that covers bridge repair, replacement, and reconstruction if the projects meet certain standards or conditions. A copy of this permit is included in Appendix D of this handbook.

Work may be performed on eligible bridges upon filing of a notice with the New England District, USACE, prior to commencing work. Eligible bridges must have a MassDOT Bridge Number; both bridge spans and certain culverts may therefore be eligible if they meet this criterion, in addition to the other conditions stipulated in the permit. The Standards and Conditions for the Comprehensive Permit for Bridges specify that the following projects are not eligible under this permit, and must be reviewed under the MGP (discussed in the previous section) or under an Individual Permit application:

- *More than 5,000 square feet of impact to vegetated wetlands or waters;*
- *Bridges crossing a Federally-designated Wild and Scenic River;*
- *Projects involving work on Corps properties and Corps-controlled flood easements such as the Charles River Natural Valley Storage Area;*
- *Proposed bridge replacements where the low chord will intersect the 10-year flood elevation;*
- *Bridges that have been identified by the Massachusetts Office of Coastal Zone Management as potentially causing restrictions to tidal flows;*
- *Projects which may affect any federally listed endangered species or their habitat;*
- *Any project located in an historic district or where there may be an effect to any National Register eligible property unless impacts have been addressed pursuant to the Programmatic Agreement (PA) between Federal Highway Administration and the State Historic Preservation Officer or any subsequent Corps of Engineers PA to satisfy the requirements of Section 106 of the National Historic Preservation Act;*

---

<sup>16</sup> See Appendix A of the MGP, under "I. INLAND WATERS AND WETLANDS, (c) RIVER/STREAM/BROOK WORK & CROSSINGS and WETLAND CROSSINGS" for a list of criteria for distinguishing Category 1 from Category 2 activities in non-tidal, non-Section 10 waters for stream and wetland crossing projects.

- For a bridge span or arch:
  - The proposed open span waterway width at ground level is less than the existing structure's span. However, this qualification does not apply if the new span width is at least 1.2 times the geomorphic bank full width of the stream;
  - The proposed bridge span or arch span constricts flow over a bedrock dominated streambed, resulting in impassable stream flow velocities;
  - There is a dam or other structural element (other than a bridge abutment or pier) that obstructs the channel within the footprint of the proposed bridge span or arch span;
  - A proposed "bridge" that consists of a culvert that is rated as a moderate or severe barrier to aquatic organism passage. A moderate or severe barrier is a structure with a Crossing Rating of less than 3, based on an evaluation using the "MassDOT Stream Crossing Structures Rating Chart".<sup>17</sup>

Designers should document eligibility for bridge projects proposed for implementation under this permit. Eligible projects must meet the Standards and Conditions set forth in the permit.

Designers should also note the Standards and Conditions of the Comprehensive Permit for Bridges include a number of measures for management of potential construction impacts, including but not limited to:

- Water control measures during construction. The CPB includes Figures 1-8 presenting specific Best Management Practices for water handling and turbidity control during construction;
- Construction timing and sequencing; and
- Construction debris containment.

Designers should note the Massachusetts DEP 401 Water Quality Certification for this permit also provides for specific conditions including, but not limited to the following:

- Conditions for temporary fills;
- Turbidity control;
- Erosion and sediment control, including measures regarding temporary stabilization, fertilization, and mulching;
- Restrictions on equipment access within wetlands and waterways;
- Prohibition of trench excavation in flowing waters; and
- Inspection access for regulatory personnel.

### 2.7.3 Massachusetts 401 Water Quality Certification Regulations

The Massachusetts DEP issued revised regulations at 314 CMR 9.00: 401 Water Quality Certification for Discharge of Dredged or Fill Material, Dredging, and Dredged Material Disposal in Waters of the United States Within the Commonwealth (401 Regulations) on December 26, 2007, and subsequent revisions on January 2, 2008. This regulation governs the placement of fill in wetlands and waterways, in addition to regulating dredging activity and the handling of dredged materials. Under 314 CMR 9.00, certain projects

---

<sup>17</sup> See Appendix B of this handbook.

do not require filing of a separate 401 Certification application, provided the projects meet specified conditions. This includes the following (see 314 CMR 9.03):

- Activities are conducted in compliance with the Wetlands Protection Act, receiving a Final Order of Conditions under 310 CMR 10.00;
- The work results in the loss of less than 5,000 square feet of cumulative impact on bordering and isolated vegetated wetlands and land under water;
- The Final Order of Conditions provides for at least 1:1 replacement of bordering vegetated wetlands;
- The activity conforms to the Waterways Crossing requirements at General Condition 21 in the Programmatic General Permit; and
- The work is not otherwise subject to a separate permit application under other provisions of the 401 Regulations.

Thus, for projects subject to review and permitting under the Wetlands Protection Act (the forum for review of most waterway crossing projects in Massachusetts), the DEP has identified the Section 404 PGP (which has now been superseded by the MGP discussed in a previous section) as the applicable standard.

314 CMR 9.04 requires a 401 Water Quality Certification Application for certain types of projects, including (but not limited to) activities that result in dredging or filling in any Outstanding Resource Water (ORW), or activities involving greater than 5,000 square feet of cumulative loss of bordering and isolated vegetated wetlands and land under water. If an application is required, then Section 9.06 sets forth criteria for the evaluation of the application. 9.06(3) governs the discharge of dredged or fill material in ORW's, including Section 9.06(3)(f):

*Construction of utilities, public or private roadways or other access except as specified in 314 CMR 9.06(3)(e), railroad track and rail beds and facilities directly related to their operation. These activities require use of a span or other bridging technique, unless the Department determines, based on information contained in a Department 401 alternatives analysis, a Corps of Engineers Section 404 alternatives analysis, or an Environmental Impact Report and the Secretary's certificate, that this alternative is not practicable, would not have less adverse impact on the aquatic ecosystem, or would have other significant adverse environmental consequences.*

Thus, for roadway projects subject to 401 Water Quality Certification review and involving a crossing of an ORW, a span or other bridging technique is required unless an alternative has been documented and approved under the application process. (Note: residential subdivision roadways are covered under other provisions of 314 CMR 9.06.)

Table 2-4. Eligibility Requirements for MassDOT Stream Crossing Structures under ACOE Comprehensive Permit for Bridges and MA General Permit Categories 1 and 2

Type of Activity	Comprehensive Permit for Bridges Eligibility Criteria	MA General Permit Category 1 Eligibility Criteria	MA General Permit Category 2 Eligibility Criteria
General	<p>For work under the General Permit: All temporary and permanent crossings (see Note 3) of rivers, streams, brooks, etc. (hereon referred to as "streams") shall be suitably culverted, bridged, or otherwise designed to i) withstand and prevent the restriction of high flows, and ii) not obstruct the movement of or not substantially disrupt the necessary life-cycle movements of those species of aquatic life indigenous to the waterbody, including those species that normally migrate through the area, beyond the actual duration of construction unless the activity's primary purpose is to impound water.</p>	<p>For work under the General Permit: All temporary and permanent crossings (see Note 3) of rivers, streams, brooks, etc. (hereon referred to as "streams") shall be suitably culverted, bridged, or otherwise designed to i) withstand and prevent the restriction of high flows, and ii) not obstruct the movement of or not substantially disrupt the necessary life-cycle movements of those species of aquatic life indigenous to the waterbody, including those species that normally migrate through the area, beyond the actual duration of construction unless the activity's primary purpose is to impound water.</p>	<p>For work under the General Permit: All temporary and permanent crossings (see Note 3) of rivers, streams, brooks, etc. (hereon referred to as "streams") shall be suitably culverted, bridged, or otherwise designed to i) withstand and prevent the restriction of high flows, and ii) not obstruct the movement of or not substantially disrupt the necessary life-cycle movements of those species of aquatic life indigenous to the waterbody, including those species that normally migrate through the area, beyond the actual duration of construction unless the activity's primary purpose is to impound water.</p>
New Stream Crossing	<p>Not eligible: See Corps Category 1, Category 2, or Individual Permit requirements</p>	<ul style="list-style-type: none"> <li>Does not temporarily or permanently affect upstream or downstream flood conditions</li> <li>Does not permanently impact wetlands</li> <li>Must meet the General Standards of the MA River and Stream Crossing Standards</li> <li>Span required; faces of abutments and footings must be landward of 1.2 times bankfull width of the stream</li> <li>Minimum width at ground level of 5 feet</li> <li>No open trench excavation in flowing waters; must meet requirements of GP relative to water handling</li> <li>In-stream construction must meet time of year restrictions</li> <li>Temporary stream crossings or cofferdams shall be used for equipment access across streams. Areas of fill and/or cofferdams must be included in total waterway/wetland impacts.</li> </ul>	<ul style="list-style-type: none"> <li>&lt; 5,000 square feet of impact to vegetated wetlands or waters</li> <li>Should use the least intrusive and environmentally damaging method to construct new crossing, following the sequential minimization process:                             <ol style="list-style-type: none"> <li>Spans with no stream impacts,</li> <li>Spans with stream impacts</li> <li>Embedded culverts with stream simulation or low-slope design</li> </ol> </li> <li>Temporary stream crossings or cofferdams shall be used for equipment access across streams. Areas of fill and/or cofferdams must be included in total waterway/wetland impacts.</li> </ul>
Replacement Crossing	<p>Structure must have a MassDOT Bridge Number and meet the following conditions:</p> <ul style="list-style-type: none"> <li>&lt; 5,000 square feet of impact to vegetated wetlands or waters</li> <li>Not a crossing of a Wild and Scenic River</li> <li>No work on Corps properties and Corps-controlled flood easements</li> <li>Low chord is above the 10-year flood elevation</li> <li>Not identified by CZM as potentially restricting tidal flows</li> <li>Will not likely affect any federally listed endangered species or their habitat</li> <li>Not located in an historic district or where there may be an effect to any National Register eligible property unless impacts have been addressed pursuant to the Programmatic Agreement (PA) between Federal Highway Administration and the State Historic Preservation Officer or any subsequent Corps of Engineers PA to satisfy the requirements of Section 106 of the National Historic Preservation Act</li> <li>For a bridge span or arch:                             <ul style="list-style-type: none"> <li>The proposed open span waterway width at ground level <math>\geq</math> the existing structure's span. However, this qualification does not apply if the new span width is at least 1.2 times the geomorphic bank full width of the stream</li> <li>The proposed bridge span or arch span does not restrict flow over a bedrock dominated streambed, resulting in impassable stream flow velocities</li> <li>There is no dam or other structural element (other than a bridge abutment or pier) that obstructs the channel within the footprint of the proposed bridge span or arch span</li> </ul> </li> <li>A proposed "bridge" that consists of a culvert if rated <math>\geq</math> 3, based on an evaluation using the "MassDOT Stream Crossing Structures Rating Chart." Culverts rated less than 3 (severe or moderate barriers) are not eligible under the CPB</li> </ul> <p>If not eligible according to the above criteria, see Corps Category 1, Category 2, or Individual Permit requirements</p>	<ul style="list-style-type: none"> <li>&lt; 5,000 square feet of impact to vegetated wetlands or waters</li> <li>Does not temporarily or permanently affect upstream or downstream flood conditions</li> <li>Does not permanently impact wetlands</li> <li>Should meet the General Standards of the MA River and Stream Crossing Standards</li> <li>Must meet General Standards 2 and 4 (culverts must be embedded as specified in these standards, and have natural bottom substrate within the structure)</li> <li>Should use the least intrusive and environmentally damaging method to construct replacement crossing, following the sequential minimization process:                             <ol style="list-style-type: none"> <li>Spans with no stream impacts,</li> <li>Spans with stream impacts</li> <li>Embedded culverts with stream simulation or low-slope design</li> <li>Spans with no stream impacts,</li> <li>Spans with stream impacts</li> <li>Embedded culverts with stream simulation or low-slope design</li> </ol> </li> <li>No slip lining (retrofitting an existing culvert by inserting a smaller diameter pipe)</li> <li>No plastic or HDPE pipe</li> <li>No open trench excavation in flowing waters; must meet requirements of GP relative to water handling</li> <li>In-stream construction must meet time of year restrictions</li> <li>Replacement crossings of the following high quality stream segments are not eligible for Category 1:                             <ul style="list-style-type: none"> <li>NHESP Living Water Cores</li> <li>NHESP BioMap cores</li> <li>ACECs</li> <li>Anadromous Fish Runs</li> <li>Cold Water Fisheries</li> </ul> </li> <li>Temporary stream crossings or cofferdams shall be used for equipment access across streams. Areas of fill and/or cofferdams must be included in total waterway/wetland impacts.</li> <li>Culvert extensions do not qualify for Category 1.</li> </ul>	<ul style="list-style-type: none"> <li>&lt; 5,000 sq. ft. to one acre of impact to vegetated wetlands or waters</li> <li>Should use the least intrusive and environmentally damaging method to construct replacement crossing, following the sequential minimization process:                             <ol style="list-style-type: none"> <li>Spans with no stream impacts,</li> <li>Spans with stream impacts</li> <li>Embedded culverts with stream simulation or low-slope design</li> </ol> </li> <li>Temporary stream crossings or cofferdams shall be used for equipment access across streams. Areas of fill and/or cofferdams must be included in total waterway/wetland impacts.</li> </ul>

Table 2-4. Eligibility Requirements for MassDOT Stream Crossing Structures under ACOE Comprehensive Permit for Bridges and MA General Permit Categories 1 and 2 (Continued)

Type of Activity	Comprehensive Permit for Bridges Eligibility Criteria	MA General Permit Category 1 Eligibility Criteria	MA General Permit Category 2 Eligibility Criteria
Maintenance (See Note 2).	<p>Certain maintenance activities are not subject to regulation, see Note 2. If subject to regulation, CPB Eligibility same as for Replacement Structures above.</p>	<p>Certain maintenance activities are not subject to regulation, see Note 2. If subject to regulation, Category 1 eligibility criteria for stream and wetland crossing work same as above.</p> <p>Also, repair, replacement &amp; maintenance of authorized fills with no expansion or change in use:</p> <ul style="list-style-type: none"> <li>• Conditions of original authorization apply</li> <li>• Minor deviations in fill design allowed (see Note 2)</li> </ul>	<p>Certain maintenance activities are not subject to regulation, see Note 2. If subject to regulation, Category 2 eligibility criteria for stream and wetland crossing work same as above.</p> <p>Also, repair/maintenance of currently serviceable authorized fills, or replacement of non-serviceable authorized fills, &lt; 1 acre, including expansion or a change in use.</p> <p>Replacement of non-serviceable authorized fills, including expansion or a change in use, totaling &lt; 1 acre</p>
Temporary Crossing	<p>Not explicitly discussed under the CPB</p>	<p>Temporary spans (abutments and footings landward of the bankfull width)</p> <ul style="list-style-type: none"> <li>• Temporary spans shall be removed within 180 days</li> </ul> <p>Temporary stream crossings that aren't spans (typically culverts) shall be constructed outside of the time of year (TOY) restrictions and must be removed before the beginning of the TOY restriction of that same season. Those that will remain into the TOY restriction will require Category 2 review.</p> <ul style="list-style-type: none"> <li>• Placed on geotextile fabric or other material where practicable to ensure restoration to the original grade. Soil may not be used to construct or stabilize these structures and rock must be large enough to allow for easy removal without disrupting the streambed.</li> <li>• Designed and maintained to withstand and pass high flows. Water height should be no higher than the top of the culvert's inlet. A minimum culvert diameter of two feet is required to pass debris.</li> <li>• Culverts must be aligned to prevent bank erosion or streambed scour.</li> <li>• Equipped with energy dissipating devices installed downstream if necessary to prevent scour.</li> <li>• Designed and maintained to prevent soil from entering the waterbody.</li> <li>• Removed upon the completion of work. Impact to the streambed or banks requires restoration to their original condition using stream simulation methods.</li> </ul>	<p>Temporary spans not meeting Category 1 shall be</p> <ul style="list-style-type: none"> <li>• Placed on geotextile fabric or other material where practicable to ensure restoration to the original grade. Soil may not be used to construct or stabilize these structures and rock must be large enough to allow for easy removal without disrupting the streambed.</li> <li>• Designed and maintained to withstand and pass high flows. Water height should be no higher than the top of the culvert's inlet. A minimum culvert diameter of two feet is required to pass debris.</li> <li>• Culverts must be aligned to prevent bank erosion or streambed scour.</li> <li>• Equipped with energy dissipating devices installed downstream if necessary to prevent scour.</li> <li>• Designed and maintained to prevent soil from entering the waterbody.</li> <li>• Removed upon the completion of work. Impact to the streambed or banks requires restoration to their original condition using stream simulation methods.</li> </ul>

Notes:

- (1) If not eligible under the CPB, Category 1, or Category 2, crossing must be submitted for review under an Individual Permit. Also, other work on the project (in addition to the actual stream crossing) may affect thresholds and criteria for consideration as Category 1 or Category 2. Refer to the MGP.
- (2) The following note is reproduced from the Corps MA General Permit, Appendix A, Endnote 15:  
 Maintenance: In accordance with 33 CFR 323.4(a)(2), any discharge of dredged or fill material that may result from any of the following activities is not prohibited by or otherwise subject to regulation under Section 404 of the CWA: "Maintenance, including emergency reconstruction of recently damaged parts, of currently serviceable structures such as dikes, levees, groins, riprap, breakwaters, causeways, bridge abutments or approaches, and transportation structures. Maintenance does not include any modification that changes the character, scope, or size of the original fill design." (This could include replacement work if it meets this definition, and stream crossings typically must be an exact replica crossing in the same footprint to qualify.) Otherwise, the following work is regulated and subject to the Category 1 or 2 thresholds in [MA GP Appendix A]: The repair, rehabilitation, or replacement of any previously authorized, currently serviceable structure or fill, or of any currently serviceable structure or fill authorized by 33 CFR 320.3 – "Activities occurring before certain dates," provided that the structure or fill is not to be put to uses differing from those uses specified or contemplated for in the original permit or the most recently authorized modification. Minor deviations in the structure's configuration or filled area, including those due to changes in materials, construction techniques, or current construction codes or safety standards that are necessary to make the repair, rehabilitation, or replacement are authorized. Currently serviceable means useable as is or with some maintenance, but not so degraded as to essentially require reconstruction. Only structures or fills that were previously authorized and are in compliance with the terms and condition of the original authorization can be maintained as a non-regulated activity under 33 CFR 323.4(a)(2), or in accordance with the Category 1 or 2 thresholds in [MA GP Appendix A. Note: The state's maintenance provisions may differ from the Corps and may require reporting and written authorization from the state.
- (3) This does not apply to constructed drainage systems designed primarily for the conveyance of storm water or irrigation.

### 3.0 Criteria for Wildlife Passage at Bridges and Culverts

This chapter outlines MassDOT’s criteria for addressing wildlife accommodation considerations at roadway crossings of freshwater streams on a project-by-project basis. The criteria vary, depending on whether the project consists of maintenance activity, replacement/reconstruction, or provision of a new stream crossing structure. For each of these broad categories of activities, there are differing opportunities and constraints for the provision of wildlife passage. Subsequent chapters then discuss in detail the design methodologies and pertinent constraints for meeting these criteria.

The following pages include guidance intended to outline “Best Practices” for providing wildlife accommodation at freshwater stream crossings, while recognizing constraints that govern the selection, design, construction, and maintenance of bridges and culverts. The guidance intends these practices to comply with regulatory requirements applicable to new and replacement structures at river and stream crossings, including applicable measures of the *Massachusetts River and Stream Crossing Standards*.

This chapter describes criteria for consideration of wildlife passage at roadway stream crossings for the following broad categories of MassDOT activities:

- Maintenance repair/reconstruction: MassDOT maintains roadway infrastructure to provide for the continuing safety and serviceability of existing roadways. These activities sometimes require repair or replacement of part or all of an existing culvert or bridge structure, to prevent a failure of the road surface, supporting structure, and embankment.
- Reconstruction: Many MassDOT projects are planned and designed for the reconstruction and replacement of roadways and roadway structures (including bridges and culverts at stream crossings) to improve and upgrade existing roadways to meet evolving transportation needs and safety standards. These projects proceed under the Department’s development and design process, and provide opportunities to address wildlife passage in conjunction with the other project objectives.
- New construction: MassDOT undertakes construction of new roadways to meet the transportation needs of the Commonwealth of Massachusetts. Where these projects require new stream crossings, the selection and design of structures will require integration of wildlife accommodation.

The following subsections describe the criteria applicable to these activities:

- 3.1. Criteria for maintenance activities;
- 3.2. Criteria for replacements of existing stream crossings that are not considered maintenance activities;
- 3.3. Criteria for construction of new stream crossings;
- 3.4. Exceptions;

3.5. Required constraints analysis; and

3.6. Order of preference of alternatives.

Subsequent chapters of this guidance document provide additional detailed information to support this planning and design approach, including:

- Design methodologies for wildlife accommodation at bridges and culverts (Chapter 4),
- Constraints to consider in the application of these methodologies (Chapter 5); and
- Implementation of the criteria through MassDOT’s development and design process (Chapter 6).

### 3.1 Criteria for Maintenance Activities

MassDOT conducts maintenance activities to respond to conditions that could imminently affect the integrity of the roadway, associated structures (such as bridges and culverts), and the supporting embankment. By their nature, MassDOT does not and cannot conduct these activities as “projects” under the development and design process that has been established for MassDOT’s roadway improvement projects. Instead, MassDOT implements these activities under the immediate direction of the Department’s maintenance personnel at the District or maintenance region level.

Often, maintenance activities require the major repair or replacement of culverts, bridge components, and their ancillary structures (e.g., headwalls, scour protection measures). In many cases, these maintenance activities provide little opportunity for addressing wildlife accommodation issues. Maintenance personnel undertake them to prevent the failure of the roadway embankment, pavement structure, and crossing structure and to preserve the integrity of the transportation system. Structure repairs/replacements typically consist of “in-kind” measures to restore the integrity of the original structures.<sup>18</sup> Corrections of barriers to wildlife passage are often difficult to implement as part of maintenance activities, because such corrective action requires more extensive analysis, design, and regulatory review than occurs under the immediacy of a maintenance repair project. However, as discussed below, there may be opportunities to improve wildlife accommodation in conjunction with maintenance activity.

Maintenance that does not include modification that changes the character, scope, or size of the original fill design may be exempt from Corps review; this generally requires stream crossing replacement to comprise an exact replica in the same footprint. An adjustment in vertical alignment may be permissible (consistent with General Condition 21(g) of the MGP, to correct a drop at culvert inlet or outlet, if the adjustment does not result in other adverse impacts to aquatic organism passage. Such maintenance needs to use water handling techniques that the Corps does not consider as “fill.” For example, temporary

---

<sup>18</sup> This Handbook focuses on accommodation of wildlife at stream crossings. However, MassDOT sometimes needs to control wildlife activity at a bridge or culvert to prevent obstruction of flows or damage to the structure. A primary example of this corrective action is the control of beaver access, to prevent these animals from constructing beaver dams within or in close proximity to the crossing. The scope of this Handbook does not include discussion of this particular problem and its solutions. Maintenance personnel should consult with District Environmental staff and local Departments of Health to address beaver related problems.



port-a-dams, water-filled dams, and steel/wood/vinyl sheeting are considered non-jurisdictional measures for construction phase water management, while sandbag and jersey barrier dams are considered jurisdictional “fills.”

Maintenance work that does not meet the provisions for non-regulated activity as described in the MGP, Appendix A, Endnote 15, is subject to review as discussed in Chapter 2.

Maintenance that goes beyond minor deviations of structure configuration may present a good opportunity to provide improved hydraulic capacity, as well as improved passage for aquatic organisms and other wildlife. District personnel should carefully consider whether a structure should be repaired in-kind, thus temporarily extending the life of a crossing that may have hydraulic or habitat limitations, or whether long-term benefits warrant providing an upgrade that incorporates features recommended by the Massachusetts River and Stream Crossing Standards.

When these maintenance projects are implemented, District personnel should note any apparent uncorrected conditions inhibiting wildlife passage, so that future improvement projects consider these conditions during project planning and development. Further, such maintenance work should be limited to the immediate structure, and involve the minimum work practicable in adjacent streambed or other wetland resource areas.

The following criteria apply to maintenance activities involving repair or replacement of existing culvert or bridge structures:

**Basic Criteria:**

These criteria apply to the replacement and repair of currently serviceable stream crossing structures, to maintain roadway and structure integrity and/or prevent failure of a culvert, bridge structure, or ancillary structure (e.g., headwall, inlet or outlet scour protection measure). These criteria do not apply to projects developed and designed under the procedures described in the MassDOT *Project Development and Design Guide*.

1. Repairs and replacements should be limited to the damaged or deteriorated structure, and not extend into adjacent resource areas except as required to complete the required repair.
2. The conduct of such repairs shall implement water handling and erosion/sediment control provisions as stipulated by the US Army Corps of Engineers Massachusetts General Permit (MGP) (see Appendix C). As noted in the above discussion, the Corps considers certain water handling measures as “fill” subject to regulatory review.
3. Personnel responsible for implementing the maintenance activity should consult the District Environmental Engineer regarding applicable permits, including obtaining emergency authorizations from the appropriate permitting agencies and “after the fact” filings required for emergency repairs when necessary for public health and safety.
4. A replacement structure should be essentially similar in design to the replaced structure, to the maximum extent practicable. For this purpose, a “similar design” is one that maintains hydraulic capacity, does not significantly increase flow velocities or flood elevations, and provides for similar

or improved embedment as the replaced structure. Personnel overseeing this maintenance will need to carefully consider whether the replacement can be implemented as an activity exempt from Corps review, or if it is considered a regulated activity subject to the CPB or MGP. Consideration should be given to improvements to enhance wildlife accommodation, particularly if more than minor deviations in structure configuration or fill are required.

5. At the time the repair is completed, the responsible personnel should note uncorrected conditions at the crossing structure that may affect the accommodation of wildlife, and report this information to the corresponding District Environmental Engineer. MassDOT personnel should evaluate this information during future project planning and development, so that future roadway and structure improvement projects address these conditions.

### **Enhanced Wildlife Accommodation**

If feasible and prudent under the conditions at the site of a repair/replacement, MassDOT maintenance personnel, in consultation with their District Environmental Engineer, should consider the following measures to enhance aquatic species passage when implementing a maintenance replacement activity:

1. Lower the pipe. The replacement structure invert may be altered to offset an existing drop (e.g., a “perched culvert” may be reconstructed with a lower invert), if the replacement structure is designed in such a way that it meets the following conditions:
  - a. It does not increase velocities at the inlet or outlet of the structure;
  - b. It does not result in a drop at the inlet or outlet of the structure;
  - c. It does not increase scour at the inlet or the outlet of the structure;
  - d. It does not expose the upstream channel to potential erosive scour, which could result in “head-cutting” of the upstream channel
  - e. It does not result in other type of physical barrier to fish and wildlife passage.

Note that this option may be limited, because it implies restrictions on the hydraulic characteristics of the replacement structure that may be difficult to implement without analysis and design exceeding the scope of the maintenance project. For example, it may not be possible to lower both the outlet and the inlet of a culvert pipe to account for the impact of slope on flow velocity, without introducing other modifications into the design of the culvert.

2. Install a guidance barrier. If the replacement structure is of sufficient size to accommodate terrestrial or semi-aquatic wildlife, a barrier (fencing, retaining wall, or other measure) may be investigated to ‘guide’ wildlife through the structure. District Personnel should only consider such measures in consultation with Environmental Section staff and natural resource agencies. Barrier guides can inadvertently become permanent barriers to other non-target species, and should be considered in light of long-term impacts.

3. Enhance passage for aquatic species by widening the span and embedding the structure. Consider implementing measures to meet Massachusetts River and Stream Crossing General Standards 2 (spanning 1.2 times bankfull width), 4 (natural bottom substrate), and 5 (appropriate stream bedforms) to enhance aquatic species passage when implementing a maintenance replacement activity.

### **3.2 Criteria for Replacements of Existing Stream Crossings that Are Not Considered Maintenance Activities**

For projects conducted under the Department’s Development and Design Process, the MassDOT *Project Development and Design Guide* (2006) requires the consideration of environmental context in the selection and design of stream crossings. Chapter 14 of that document specifically addresses wildlife accommodation, including citations to the Massachusetts River and Stream Crossing Standards. Figure 3-1 presents a “decision flow diagram” adapted from Chapter 14 of the *Project Development and Design Guide*, and serves as a guide whether to consider wildlife accommodation on a project involving a new stream crossing or a reconstruction or replacement of an existing crossing.

This section further describes criteria for addressing wildlife accommodation when reconstructing or replacing existing structures.

The replacement of existing crossings of rivers or streams<sup>19</sup> should meet the following criteria, unless there is a compelling reason that the design cannot meet the criteria (see discussion under Section 3.4. Exceptions):

#### **Basic Criteria:**

Certain regulatory programs (see Chapter 2) require that replacements of existing crossings be designed to

*“withstand and prevent the restriction of high flows... and not obstruct the movement of or not substantially disrupt the necessary life-cycle movements of those species of aquatic life indigenous to the waterbody, including those species that normally migrate through the area, beyond the actual duration of construction...”*

Therefore, replacement crossings should be designed to meet the following criteria:<sup>20</sup>

(Continued on Page 44)

---

<sup>19</sup> For purposes of this document, streams include intermittent streams as well as perennial streams, but do not include ditches or other man made channels designed and maintained for the management of storm water runoff.

<sup>20</sup> Note that proposed replacement structures that do not meet the terms of MGP General Condition 21 should be evaluated for eligibility under the Comprehensive Permit for Bridges. If ineligible for the CPB, then these structures will require ACOE Category 2 review.

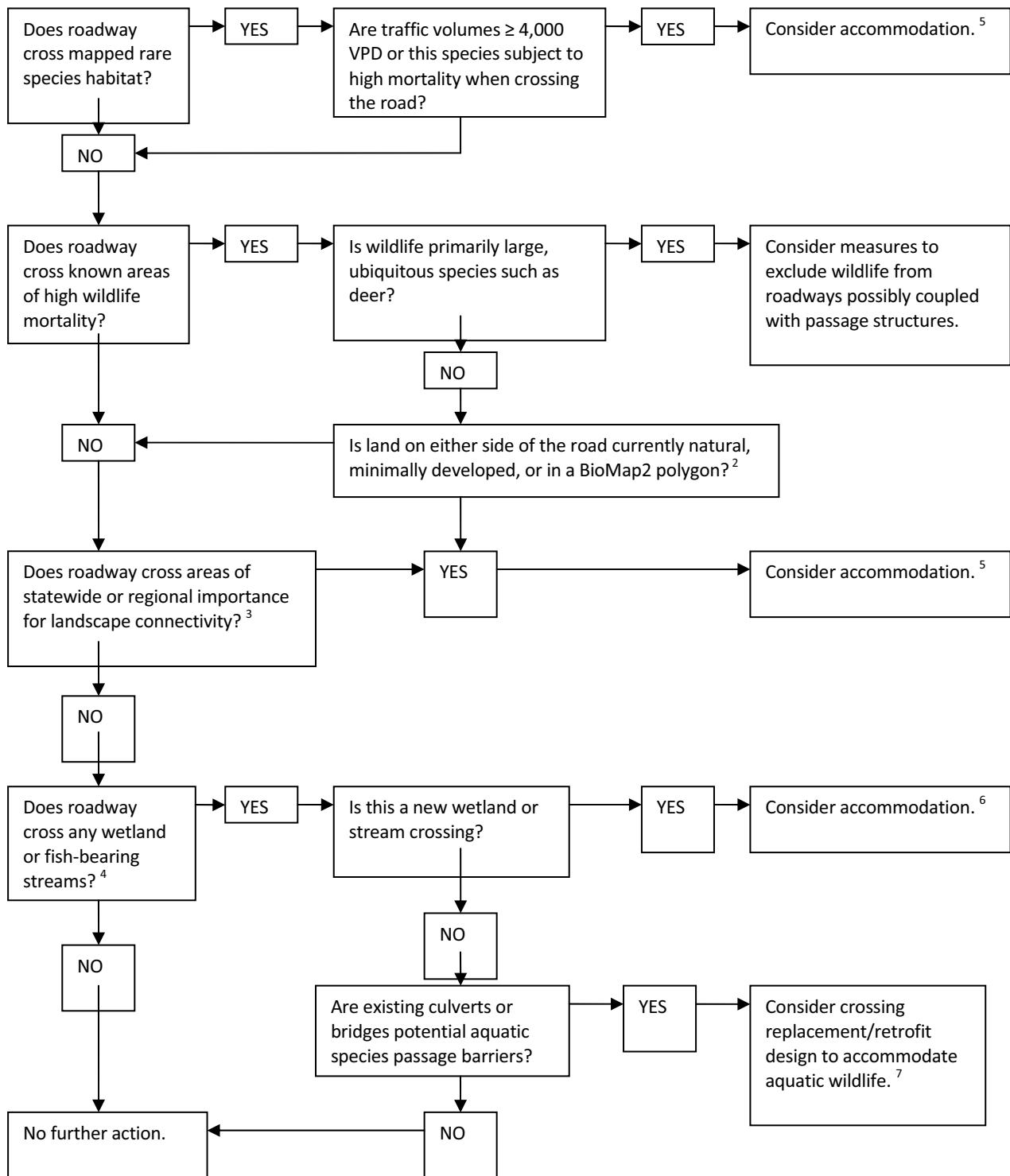

Figure 3-1. MassDOT Project Wildlife Accommodation Scenarios for New and Replacement Stream Crossings.

### **Footnotes to Figure 3-1**

1. Adapted from Figure 14-1, MassDOT *Project Development and Design Guide*. The decision matrix in this figure applies to projects subject to the MassDOT Development and Design process. It does not apply to maintenance/repair projects.
2. See NHESP BioMap2  
[http://www.mass.gov/dfwele/dfw/nhesp/land\\_protection/biomap/biomap\\_home.htm](http://www.mass.gov/dfwele/dfw/nhesp/land_protection/biomap/biomap_home.htm)
3. As stated in the *Massachusetts River and Stream Crossing Standards*:  
  
“Areas of particular statewide or regional significance for their contribution to landscape level connectedness include, but are not limited to, rivers/stream and associated riparian areas that serve as corridors or connecting habitat linking areas of significant habitat (>250 acres) in three or more towns.”
4. Includes streams or rivers (including intermittent streams) serving as habitat for fish and semi-aquatic wildlife that typically live within stream channels (e.g., salamanders, turtles). The determination whether a stream is “fish-bearing” or supports other wildlife should be made in consultation with natural resource agency personnel. In many cases, small and intermittent streams host a diverse range of species, and are important components of the ecosystems of headwaters streams.
5. If the roadway crosses or is within one of these habitat areas and includes a stream crossing, then consider accommodation that would meet the “Optimum Standards” of the *Massachusetts River and Stream Crossing Standards* to the maximum extent practicable.
6. New stream crossings in these areas should meet the “General Standards” of the *Massachusetts River and Stream Crossing Standards*. Wetland crossings should provide hydraulic and ecological connectivity in compliance with General Condition 22 of the Massachusetts General Permit issued under Section 404 of the Clean Waters Act.
7. Projects involving reconstruction, replacement, or retrofitting of existing stream crossing structures should correct barriers to aquatic species passage to the extent practicable. These projects should also consider meeting “General Standards” of the *Massachusetts River and Stream Crossing Standards* to the extent practicable.

## Bridges

1. Replacement structures for existing bridges should be designed to meet the *Massachusetts River and Stream Crossing Standards* to the extent practicable. At a minimum, bridges that currently do not obstruct aquatic passage may be replaced in-kind or with an alternative structure with a comparable or greater span and waterway opening.<sup>21</sup> Generally, a bridge does not obstruct aquatic passage if it spans a natural, relatively stable channel and if the bridge has no weir, dam, structural member, or other structural feature within the streambed or within the waterway area normally traversed by aquatic wildlife (e.g., for streams with anadromous fish, flows up to predominant depths during the migration period).
2. For bridges with obstructions to aquatic passage, the designer should consult with MassDOT's Environmental Section, to evaluate the structure in coordination with the resource agencies early in the development and design process, to determine acceptable criteria for addressing the obstruction.
3. If a proposed project involves the replacement of an existing bridge with a design requiring additional intermediate piers, a single span box culvert, or a multiple span box culvert, then the designer should consult with MassDOT's Environmental Section to determine acceptable criteria for the structure to accommodate wildlife. This evaluation of the structure should include coordination with the resource agencies early in the development and design process.

Where the existing bridge crosses a waterway classified by the Massachusetts Water Quality Standards as an Outstanding Resource Water (ORW), including tributaries to ORWs, then the design should consider a bridging or spanning technique for the replacement structure. Spanning or bridging techniques include bridges, open bottom arches, and open bottom culverts.

4. For a bridge located in an area of regional or statewide importance for landscape connectivity as defined by the Massachusetts Stream Crossing Standards, the designer should consider the corresponding Optimum Standards.
5. In considering wildlife accommodation for replacement bridges, the designer must consider the applicable constraints, as described in Section 3.5.

## Culverts

1. Replacement structures at existing culverts should be designed to meet the *Massachusetts River and Stream Crossing Standards* to the extent practicable. Existing culverts should be assessed whether they currently obstruct *aquatic* passage, according to procedures discussed in Chapter 2.<sup>22</sup> At a minimum, culverts that are determined to be passable by aquatic species indigenous to

---

<sup>21</sup> Note that under the ACOE Comprehensive Permit for Bridges (see Chapter 2), a replacement may in some cases have a lesser span than the existing bridge, if the resulting new span exceeds 1.2 times the geomorphic bankfull width of the stream.

<sup>22</sup> Section 2.2 discusses evaluation of existing crossings relative to wildlife passage. Under the CPB, MassDOT has developed a rating procedure (see form included in Appendix C) based on a field evaluation system developed by the Massachusetts River and

the water body may be replaced on approximately the same horizontal and vertical alignment with a culvert of approximately equal flow capacity without further analysis of wildlife passage, assuming other applicable MassDOT design criteria for such structures are met.

2. If an assessment rates an existing culvert as a barrier to aquatic passage, the designer should consult with MassDOT's Environmental Section, to evaluate the structure in coordination with the resource agencies early in the development and design process, to determine acceptable criteria for addressing the obstruction. Generally, evaluation of practicable alternatives for replacement of such structures should follow the order of preference in Section 3.6.
3. In considering wildlife accommodation for replacement culverts, the designer must consider the applicable constraints, as described in Section 3.5.

#### **Enhanced Wildlife Accommodation:**

Where the existing structure provides for aquatic passage, but may not currently comply with the guidelines outlined in the *Massachusetts River and Stream Crossing Standards*, the design should consider the following:

1. Where prudent when considered in conjunction with project costs and other engineering design criteria applicable to the crossing, the bridge or culvert selection process should evaluate alternatives that would meet the guidelines discussed in the Stream Crossing Standards under "Design Standards for Culvert Replacement."
2. This evaluation should consider site-specific stream and floodplain characteristics, habitat significance, and structural and economic feasibility.
3. Generally, the evaluation of practicable alternatives for replacement structures should follow the order of preference in Section 3.6.

### **3.3 Criteria for Structures at New Stream Crossings**

New crossings of rivers or streams should consider wildlife accommodation in accordance with Figure 3-1, and should meet the following criteria, unless there is a compelling reason that the design cannot meet the criteria (see discussion under Section 3.4. Exceptions):

#### **Basic Criteria:**

Certain regulatory programs (see Chapter 2) require that new crossings be designed to

*"withstand and prevent the restriction of high flows... and not obstruct the movement of or not substantially disrupt the necessary life-cycle movements of those species of aquatic life indigenous*

---

Stream Continuity Project. Note that culverts assessed as "minor barriers" and some culverts assessed as "moderate barriers" under this method would likely provide *aquatic* wildlife passage (although not necessarily passage for non-aquatic species).

*to the waterbody, including those species that normally migrate through the area, beyond the actual duration of construction...”*

Therefore, new crossings should be designed to meet the following criteria:

1. The structure should meet the “General Standards” of the *Massachusetts River and Stream Crossing Standards*. Bridge or spanning techniques are strongly preferred. Where spans are impracticable, pipe, box, and arch pipe culverts may be used where they can be designed to meet the dimensional, hydraulic, and streambed material requirements of the “General Standards.” Note that spans are required for a structure to be eligible for Category 1 under the MGP.
2. Where the structure crosses a waterway classified by the Massachusetts Water Quality Standards as an Outstanding Resource Water (ORW), including tributaries to ORWs, then Massachusetts regulations require a bridging or spanning technique to be used, unless otherwise approved by the MassDEP. Spanning or bridging techniques include bridges, open bottom arches, and open bottom culverts.
3. When a bridge is proposed where the width of the crossing is such that a clear span is not structurally feasible and a multiple span structure is necessary, the design team should consult with the MassDOT Environmental Section. The Environmental Section and designer should engage in early coordination with natural resource agencies to establish acceptable criteria for the placement of intermediate piers or other supporting structures within the affected streambed or stream bank. For *new* crossings, if multiple box culverts are proposed, then at least *one* of the box culverts should meet the “General Standards” (e.g., the span requirement applies to one of the culverts, not the total width of opening).
4. In designing for wildlife accommodation at new crossings, the designer must consider the applicable constraints, as described in Section 3.5.

#### **Enhanced Wildlife Accommodation:**

For a bridge located in an area of regional or statewide importance for landscape connectivity as defined in the Massachusetts River and Stream Crossing Standards, the designer should consider the following:

1. Where prudent when considered in conjunction with project costs and other engineering design criteria applicable to the crossing, the bridge selection process should evaluate alternatives that would meet the “Optimum Standards” of the Massachusetts Stream Crossing Standards.
2. This evaluation should consider site-specific stream and floodplain characteristics, habitat significance, and structural and economic feasibility.

### **3.4 Exceptions**

An alternative design to one meeting the applicable guidance listed in Sections 3.1 through 3.3 should only be considered when one or more of the following apply:



1. Structural, transportation safety, or other criteria are imposed by applicable codes and standards that cannot be reconciled with the above requirements. In this case, the design team should perform the following:
  - a. Engage in early coordination with natural resource agencies to present the reasons for the alternative structure design, and to identify mitigation, if appropriate, for the effects of the alternative design.
  - b. Meet the applicable Basic Criteria in Sections 3.1 through 3.3 to the extent practicable.
  - c. Consider the alternative designs in the order of preference specified in Section 3.6.
2. The existing river or stream is completely channelized by past urban development at the location of the crossing (for example, a stream conveyed in a vertical-sided canal), and it is unlikely that the stream would be restored to a more natural condition within the design life of the proposed structure.
3. The existing river or stream in the immediate vicinity of the proposed structure is obstructed by other existing structures (for example, dams), and it is unlikely that these obstructions will be removed within the design life of the proposed crossing structure.<sup>23</sup> If those other structures provide for passage of specific wildlife species (e.g., they include fish passage structures), then the new crossing design should include provisions for passage of the same species.
4. The design team has conducted early coordination with natural resource agencies and received written confirmation that the particular stream has no significant wildlife function.
5. Early coordination with natural resource agencies concludes that wildlife passage is either not an issue at the particular project location, or better accommodated in an alternative design.

### 3.5 Constraints Analysis

In addressing wildlife accommodation at new crossings and for replacement of existing bridges or culverts, the designer must consider the applicable constraints, including but not limited to those discussed in Chapter 5 of this document. If any of these constraints affect the practicability of meeting the criteria in Sections 3.1 through 3.3, then the designer should consult with the MassDOT Environmental Section. The designer and Environmental Section staff should engage in early coordination with federal, state, and local environmental resource agencies to establish acceptable criteria for the crossing.

At a minimum, design should consider the following:

1. The initial construction cost and the cost of ongoing maintenance of the structure.

---

<sup>23</sup> Designers should document that such existing structures are likely to remain in place, by consulting with the owners of these structures, MassDOT Highway Environmental Section, and other resource agencies such as the Massachusetts Fish and Game Division of Ecological Restoration. In some cases (for example, existing dams under consideration for removal), there may be potential opportunities for stream restoration during the service life of the proposed bridge.

2. Potential displacement of or adverse effects on other structures, land uses, or utilities in the vicinity of the crossing;
3. Alteration of existing floodplain profile or extent of flooding either upstream or downstream of the structure;
4. Alteration of existing wetlands upstream or downstream, as a consequence of placement of the bridge structure or roadway, or as a result of the hydraulic characteristics of the structure;
5. Adverse effects on streambed stability, stream bank stability, or sediment mobilization and transport characteristics either upstream or downstream of the structure;
6. Scour potential and associated affects on bridge foundations;
7. Potential environmental impacts associated with the construction process for the structure;
8. Whether the structure itself or other nearby structures have archaeological or historic significance that could be impacted by its modification;
9. The constructability<sup>24</sup> and feasibility of maintaining of the structure.

### 3.6 Order of Preference of Alternatives

Chapter 4 of this guidance document presents a range of alternatives for addressing wildlife accommodation at stream crossings. These alternatives include the following, in general order of “most passable by wildlife” to “least passable:”

- Valley Span
- Stream Span
- Stream Simulation
- No-Slope Culvert<sup>25</sup>
- Bridge Replacement with Retained Abutments (less than 1.2 times bankfull width)
- Full Span Embedded Multiple-Box Culvert
- Roughened Channel Embedded Culvert
- Simple Embedded Culvert
- Fish Passage Hydraulic Design
- Flow Conveyance Design

Chapter 4 includes descriptions of these design approaches, the conditions under which they are applicable, and references for more complete information for design.

---

<sup>24</sup> “Constructability” refers to the feasibility of constructing the particular design with equipment and materials generally available at the project site. For example, a small-diameter culvert with a stone and cobble-filled invert may not be feasible to install.

<sup>25</sup> This Handbook considers the “No-Slope Culvert” as the design alternative meeting the “low-slope culvert” option cited by the ACOE in the Massachusetts General Permit.

When considering the design of a stream crossing structure to address wildlife accommodation, and particularly when the structure cannot fully comply with applicable “General Standards” of the *Massachusetts River and Stream Crossing Standards*, this guidance recommends the order of preference listed in for selection among these available alternatives for the crossing.

**Table 3-1. Order of Preference for Alternative Design Measures for Maximizing Wildlife Passage**

Order of preference	Alternative Design Measure	Remarks
1	Valley Span or Stream Span	<p>At a minimum, strive for a clear span of stream, 1.2 times bankfull width.<sup>26</sup> Valley Span may be considered where feasible.</p> <p>Within this category, the following order of preference should be followed:</p> <ul style="list-style-type: none"> <li>a) Spans with no stream impacts</li> <li>b) Spans with stream impacts.</li> </ul>
2	Stream Simulation or No-Slope Culvert	Embedded culvert with “stream simulation” or “no slope” design, with a clear span of 1.2 times bankfull width.
3	Bridge Replacement with Retained Abutments, Full-Span Multiple Barrel Box Culvert, Roughened Channel Design	<p>Bridge span, open bottom culvert, or embedded culvert, where the span is less than 1.2 times bankfull width. Design of these alternatives should evaluate existing bed material for stability, or provide a stable bed material design (e.g., “roughened channel design”).</p> <p>This category also includes multiple barrel culvert designs, even if the combined width of all barrels exceeds 1.2 times bankfull width.</p>
4	Simple Embedded Culvert	Generally should only be considered where bed material is self-sustaining, and does not warrant a “roughened channel design” to assure bed material stability.
5	Fish Passage Hydraulic Design	Culvert with provisions for fish passage if applicable species are present.

---

<sup>26</sup>This may include a bridge replacement with retained abutments where the previous bridge provided the 1.2 times bankfull width.



## 4.0 Design Approaches for Wildlife Passage at Stream Crossings

### 4.1 Range of Ecological Solutions

River and stream crossings can be designed to provide for varying degrees of habitat continuity along the stream corridor. At a minimum, bridges and culverts are designed to convey flows from specified storm or flood events, while meeting structural requirements for the roadway crossing. However, the provision of passage for aquatic and terrestrial wildlife will require a broader range of potential crossing configurations to be considered.

As discussed in Chapter 2, the Massachusetts River and Stream Crossing Standards focus primarily on a “stream simulation design” strategy for achieving habitat continuity objectives. However, in constructing replacement crossings, and in some cases new crossings, it may not always be feasible to use the stream simulation approach. Chapter 5 addresses the potential constraints that may affect crossing design and implementation, and that may require the consideration of alternative strategies. This chapter describes a range of ecological design solutions available for stream crossings, and provides a brief summary of several design approaches that could be considered in light of specific project constraints.

Figure 4-1 shows a continuum of solutions that provide varying degrees of ecological connectivity at stream crossings. At one end of this continuum, we find the design approach that provides capacity to convey flood flows, as specified by standard engineering practices (*e.g.*, *MassDOT Project Development and Design Guide* and the *Bridge Manual*). At the other end of this range of solutions we find the design approach that permits the full range of natural processes to occur (including natural vertical and horizontal adjustments in the streambed, natural floodplain continuity, and the associated ecological processes). At the “flood capacity” end of the continuum, crossings typically consist of culverts or bridges designed for specified flood events, with end treatments developed to make these stream crossings work efficiently and to prevent damage of the structure and immediate surroundings as a result of the alteration of the natural hydraulics of the stream. At the “permit valley and floodplain processes” end of the spectrum, crossings typically consist of bridge spans over the entire active floodplain, with no or minimal structural elements (such as intermediate piers and foundations) within the floodplain. Such a “valley span” structure results in little or no interference with the dynamic geological processes of the stream valley, and readily accommodates wildlife passage beneath the structure.

In between these extremes, crossings can be designed to accommodate:

- Passage of specific species of fish at specific life stages, referred to as “fish passage hydraulic design;”
- Passage of broader ranges of aquatic organisms;
- Passage of aquatic organisms and the occurrence of some degree of natural stream process (*e.g.*, conveyance and deposition of sediment), referred to as “stream simulation” design; or

- A combination of one of the above measures with components to handle extreme flood flows (floodplain continuity). This approach seeks to maintain flood conveyance while ensuring the sustainability of bed materials within the crossing structure.

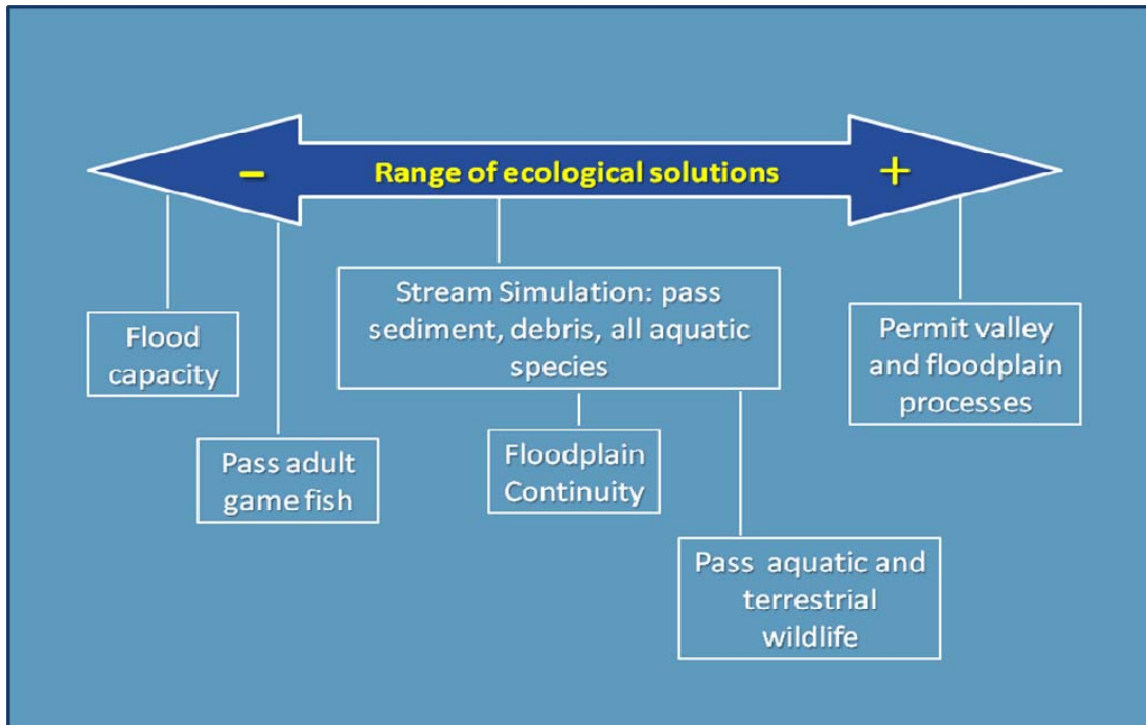

**Figure 4-1. The Range of Ecological Design Solutions at Stream Crossings**  
Adapted from Gubernick, 2003.

This range of design approaches is further illustrated in Figure 4-2. The general approaches include flow conveyance, fish passage hydraulic design, embedded culvert design, stream simulation, stream span, and floodplain span. The figure describes which of these measures apply to culverts, arches, bottomless culverts, and bridges. Figure 4-2 also indicates the general ability of each approach to meet the Massachusetts Stream Crossing Standards. In addition, the figure notes measures that are likely to apply for retrofits, replacements, and new construction. The remainder of this chapter presents a brief description of the design approaches outlined in Figure 4-2.

The design measures described below must be considered in the context of applicable project and site conditions, to address not only wildlife accommodation, but also traffic accommodation, structural integrity, and other project objectives and constraints. The choice of structure type, size, and placement may be constrained by such factors as existing floodplain elevations, limits on location of vertical roadway profile, right-of-way limitations, proximity of wetlands, constructability considerations, maintenance considerations, and costs,. The evaluation of the following measures for implementation on a project must be conducted in light of these constraints, which are further discussed in Chapter 5.

## 4.2 Summary Descriptions of Design Approaches

Table 4-1 presents a list of general design approaches available for stream crossings for varying degrees of stream continuity, ranging from “valley process” design to flood capacity design. The following pages present individual summary descriptions for each of the listed design approaches. For each of these measures, the summaries provide a description of the characteristics of the design approach, conditions where it is applicable, a schematic illustration of the approach, a list of information needed for design, and technical references that can be used for the design approach. This guidance document does not cover all the details of each design approach, but is intended to provide overall direction to the designer in selecting an approach and accessing technical information needed to implement the approach.

Note that the Valley Span, Stream Span, Stream Simulation, and No-Slope Culvert techniques (measures 1 through 4 in Table 4-1) would likely fully meet the River and Stream Crossing Standards, if they provide appropriate openness values. Designers of crossing structures should therefore use one of these techniques, unless design constraints preclude choosing one of these options (see Chapter 5 for a discussion of design constraints).

Because each river or stream crossing is unique, and because there are often significant constraints for replacement crossings, there will likely be conditions where stream crossings cannot be designed according to the techniques described for measures 1 through 4. In such cases, alternative measures will need to be considered to optimize the provision of passage for wildlife within applicable design constraints. Therefore, the other design approaches presented as measures 5 through 10 are described, to help aid in selection of an approach that can address the Standards to the maximum extent practicable.

**Table 4-1. Stream Crossing Design Approaches**

	Type	Design Approach Requires an Opening $\geq 1.2 \times$ Bankfull Width
1	Valley Span	Yes
2	Stream Span	Yes
3	Stream Simulation	Yes
4	No Slope Culvert	Yes
5	Bridge Replacement with Retained Abutments	Not typically <sup>27</sup>
6	Full Span Embedded Multiple-Box Culvert	Yes <sup>28</sup>
7	Roughened Channel Embedded Culvert	No
8	Simple Embedded Culvert	No
9	Fish Passage Hydraulic Design	No
10	Flow Conveyance Design	No

<sup>27</sup> However, if a bridge replacement with retained abutments has a span equal to or greater than 1.2 x bankfull width, it is considered a “stream span” design.

<sup>28</sup> Combined width of openings  $\geq 1.2 \times$  bankfull width.

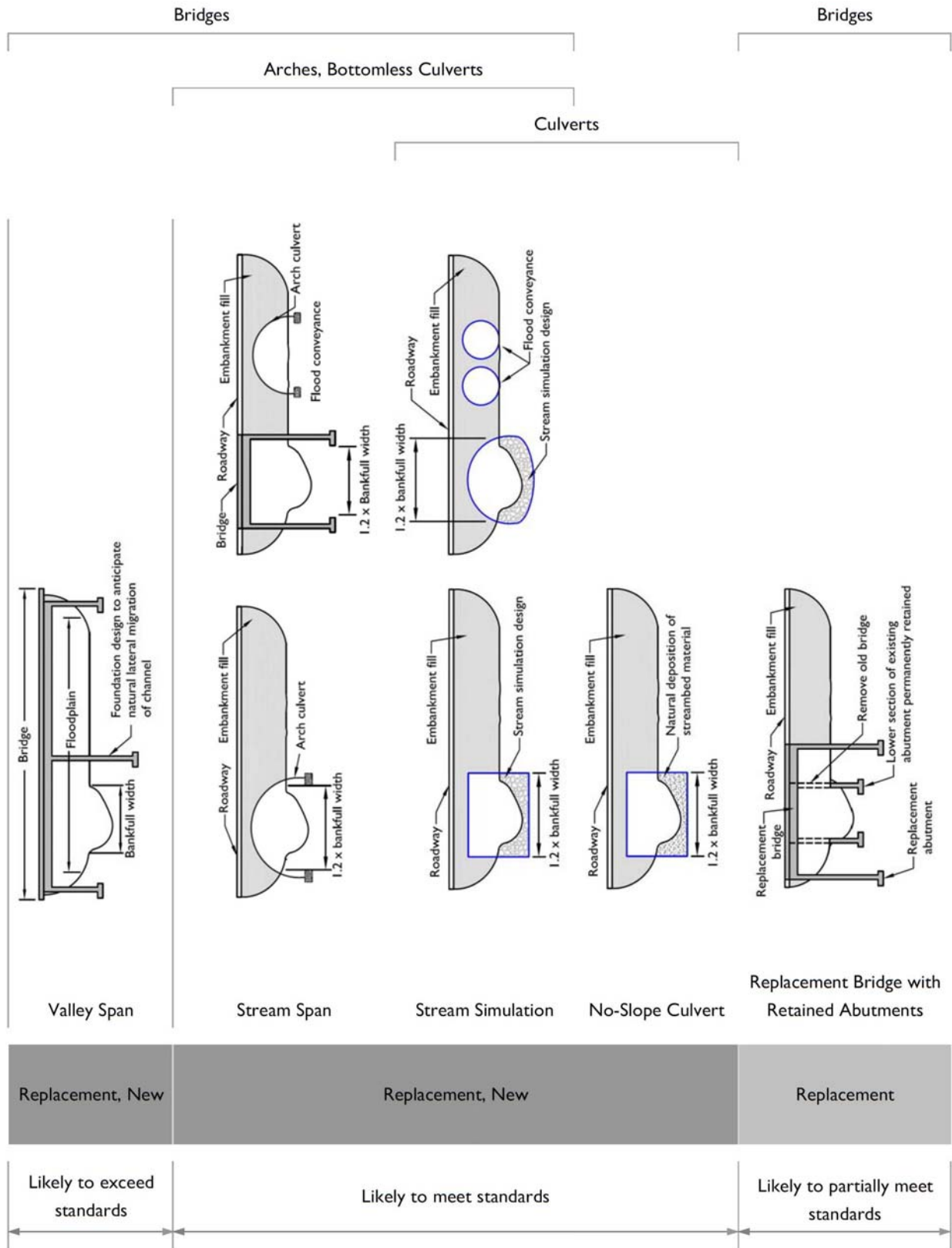



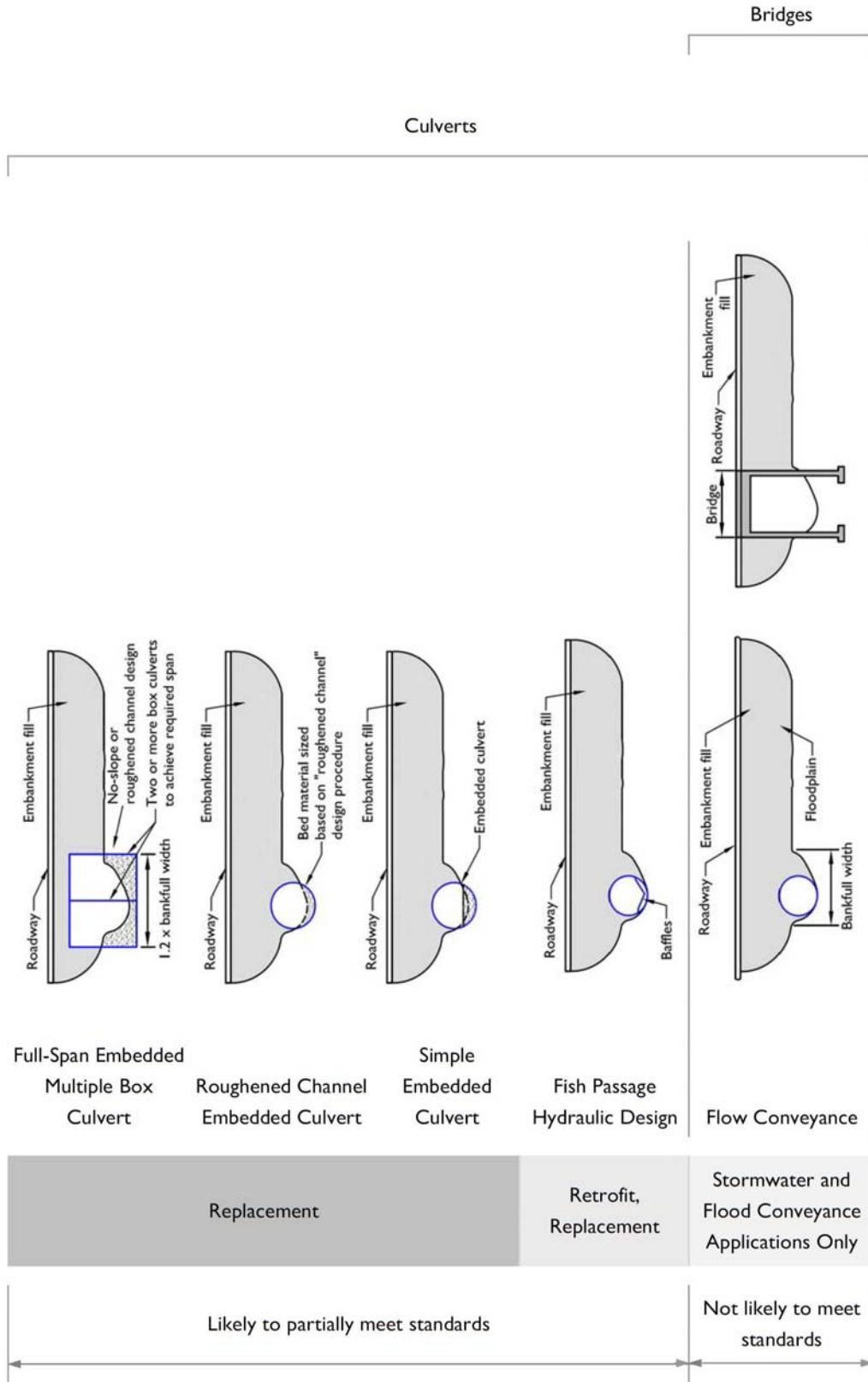

Figure 4-2. Range of Stream Crossing Design Approaches (Adapted from Gubernick, 2003).

## 4.2.1 Valley Span

### Characteristics

“Valley Span” crossing design involves the construction of a new bridge that completely spans the active floodplain of an existing stream, without disturbance of the streambed or its banks. This design approach is not likely to be used for a replacement crossing, unless the existing crossing is a valley-span structure. This type of span might have intermediate structural supports founded within the floodplain.

This type of design allows for essentially unimpeded natural geologic, hydraulic, and ecological function of the stream and its floodplain. With specified clearances for wildlife passage, it would fully meet the Massachusetts River and Stream Crossing Standards, and would likely accommodate the movement of a full range of wildlife, including large mammals.

New structures that completely span the valley should be designed in accordance with MassDOT standard practices as set forth in the references cited below. As required by such design practice, the engineer needs to evaluate the need and, as warranted, design for scour protection for bridge piers and abutments. By maintaining the clear width between vertical structural elements specified by the River and Stream Crossing Standards, the provision of features to prevent scour under flood flow conditions should be feasible with little or no impact on the active stream channel. Where the channel is subject to natural lateral migration, it is preferable to place structural elements beyond the anticipated extent of such dynamic stream behavior, but this may not be feasible in all instances. In such cases, the structural elements should be designed to protect them from scour and undermining by the dynamic behavior of the stream.

Measures should be taken during construction to protect the existing stream, consistent with the Construction Best Management Practices described in the River and Stream Crossing Standards. Generally, the valley-span design approach should require no special design procedures for replicating stream channel within the crossing.

Floodplain continuity is an inherent feature of this design.

### Conditions Where Applicable

- The Valley Span design approach is applicable to new stream crossing structures, where the stream valley can be bridged within other applicable design constraints, including the limits on span-lengths specified in the *Bridge Manual*.
- This design approach is useful where it is important to preserve natural fluvial and floodplain processes.
- If feasible within other physical design constraints, this approach may be particularly useful in areas where the movement of large mammals is of concern (areas of statewide or regional importance for landscape-scale connectivity).
- The design approach may be useful for alluvial streams with broad active floodplains, where the channel exhibits active lateral migration within the floodplain, and where locating a roadway

embankment and bridge structure would expose these facilities to risk. With strategic placement of piers (with appropriate scour protection), this design has the potential to accommodate the dynamic processes that occur in such a setting.

- The design approach may be useful for headwaters streams with steep sided valleys and narrow or poorly defined floodplains, where the full span of the floodplain can be accommodated at a reasonable cost of structure.
- This approach may be particularly adaptable for bridges for bikeways and pedestrian trails, to minimize ecological impacts of these structures.

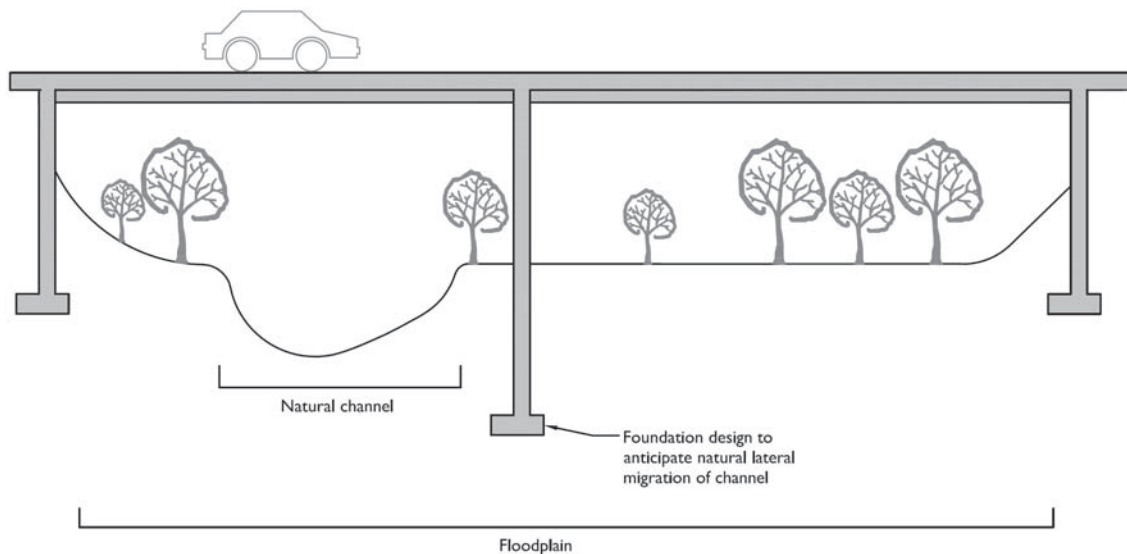

**Figure 4-3. Valley Span**

### Information Required for Design

- All information typically required for design of MassDOT bridges and culverts.
- An evaluation of the valley bedrock structure and surficial geology to the extent practicable.
- Longitudinal profile of the streambed along its thalweg for sufficient distance upstream and downstream of the crossing, to enable determination of the long-term likely stream profile through the crossing structure. An assessment should be made of existing and natural features that may affect future channel horizontal and vertical alignment. This includes an analysis of natural bed forms as revealed by the long profile, assessment of the presence of rock outcrops

that may control head-cutting, and assessment of other structures on the water course that could affect aggradation or degradation of the streambed.

- Geomorphologic assessment of the stream, including information on potential for lateral migration and vertical adjustment, sufficient to support the design of the location, depth, and scour protection of intermediate vertical structural supports for the bridge superstructure. This characterization typically includes:
  - Bankfull width, depth, and corresponding discharge;
  - Characterization of other parameters describing stream plan form and bed form;
  - Data on low flow and flood flow conditions that affect the existing stream morphology and floodplain;
  - Data to characterize grain-size distribution of substrate material, and to assess the mobility of this material under existing and proposed design conditions.

#### **Other Factors Affecting Selection and Application of this Design Approach**

- There are limits on the length of span that can be used for various types of bridges, as specified in the MassDOT *Bridge Manual*. Where the required span width exceeds this limit, then a clear span of the floodplain would not be feasible. In this case, intermediate piers would be required to support a crossing structure. These piers should be constructed to provide for a clearance of 1.2 times bankfull width between piers or abutments on opposite sides of the existing stream channel.

If the stream channel width exceeds allowable bridge span dimensions, then intermediate piers may need to be constructed in the active river channel. In such a case, the designer should coordinate with affected regulatory agencies regarding the crossing design, and work with those agencies during the “design development” phase to develop a crossing configuration that meets structural requirements, while resulting in the least impact on river and floodplain geologic and ecological processes.

#### **Reference Documents**

MassDOT. 2006. Project Development and Design Guide. Massachusetts Executive Office of Transportation. Boston, Massachusetts.

- Chapter 8 - Drainage and Erosion Control
- Chapter 10 – Bridges

MassDOT. 2006. 2005 Edition Bridge Design Manual, Parts I and II. Massachusetts Executive Office of Transportation. Boston, Massachusetts.

## 4.2.2 Stream Span

### Characteristics

Stream Span crossing design involves the construction of a new bridge, bottomless arch, or three-sided culvert over an existing stream without disturbance of the stream channel or its banks. A Stream Span crossing can also be provided for a replacement structure, where the existing structure spans the stream channel and already meets the span-width requirements of the Massachusetts River and Stream Crossing Standards. In the case of replacement structures, some stabilization or restoration of the existing stream or river may be required. If extensive work within the stream channel is necessary, then the design should be performed according to the “Stream Simulation” design approach discussed in this guidance document. If a span is used to replace an existing culvert, then stream channel construction or restoration will be necessary, and should be performed as discussed under “Stream Simulation.”

New and replacement structures that completely span the channel should be designed in accordance with MassDOT standard practices as set forth in the references cited below. As required by such design practice, the engineer needs to evaluate and design for scour protection for bridge piers and abutments. By maintaining the clear width specified by the River and Stream Crossing Standards, the provision of features to prevent scour under flood flow conditions should be feasible with little or no impact on the active stream channel. Where the channel is subject to natural lateral migration, it is preferable to place structural elements beyond the anticipated extent of such dynamic stream behavior (see Span of Stream Valley design approach). If this is not feasible, then the structural elements should be designed to protect them from scour and undermining by the dynamic behavior of the stream.

Measures should be taken during construction to protect the existing stream, consistent with the Construction Best Management Practices described in the River and Stream Crossing Standards. Generally, the Stream Span design approach should require no special design procedures for replicating stream channel within the crossing.

The designer must conduct a hydraulic analysis of the crossing structure under flood flow conditions, including an analysis of the stability of the existing streambed, to verify that the capacity of the structure is sufficient to convey the design flood while still maintaining a sustainable channel. For low-gradient stream systems, the streambed may be mobile, and the design should not adversely affect sediment transport. For moderate and steep gradient streams with naturally high stability of bed structure, the design should result in velocities and depths that do not displace the natural bed material under flood flows through the crossing. The size of the crossing structure opening can be increased if needed to accommodate design flows.

Provision of floodplain continuity may be required to ensure capacity and stability of the stream crossing structure and the affected stream. For example, “relief culverts” can be added within the active floodplain of the stream, or other measures can be employed (*e.g.*, controlled embankment overtopping) to provide for conveyance of flood flows on the natural floodplain, rather than through the primary crossing.

### Conditions Where Applicable

- The Stream Span design approach is applicable to new stream crossing structures, where the stream can be bridged with little or no disturbance of the existing stream channel and its banks.

- The design approach can be used for replacement structures, where the existing structure spans the bankfull width of the existing stream. Some restoration or stabilization of the stream banks may be required to ensure that the stream remains dynamically stable, or to restore riparian over-bank areas.
- This design approach is not applicable to enclosed culverts.

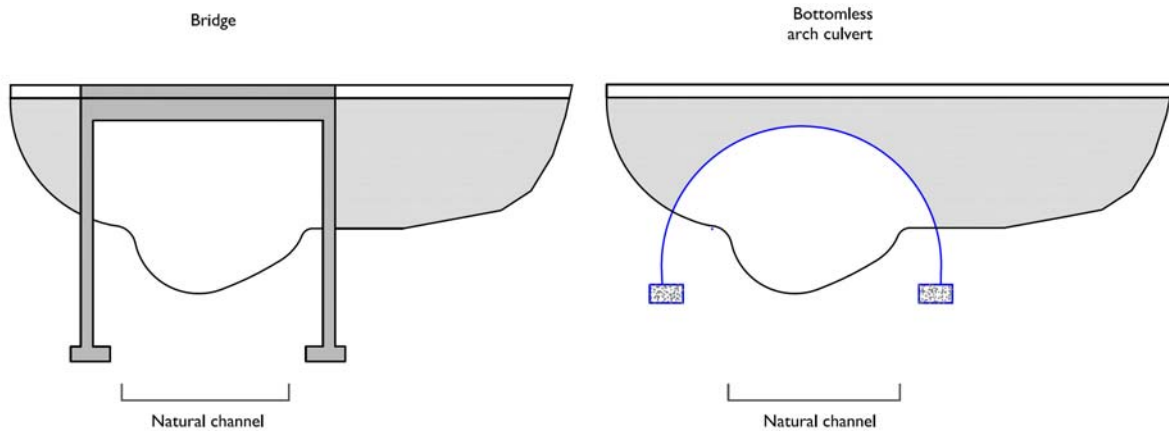

**Figure 4-4. Stream Span**

#### Information Required for Design

- All information typically required for design of MassDOT bridges and culverts.
- An evaluation of the valley bedrock structure and surficial geology to the extent practicable.
- Longitudinal profile of the streambed along its thalweg for sufficient distance upstream and downstream of the culvert, to enable determination of the long-term likely stream profile through the crossing structure. An assessment should be made of existing and natural features that may affect future channel vertical alignment. This includes an analysis of natural bed forms as revealed by the long profile, assessment of the presence of rock outcrops that may control head-cutting, and assessment of other structures on the water course that could affect aggradation or degradation of the streambed.
- Geomorphologic assessment of the stream, including information on potential for lateral migration and vertical adjustment, sufficient to support the design of the location, depth, and scour protection of intermediate vertical structural supports for the bridge superstructure. This characterization typically includes:

- Bankfull width, depth, and corresponding discharge;
  - Characterization of other parameters describing stream plan form and bed forms;
  - Data on low flow and flood flow conditions that affect the existing stream morphology and floodplain;
  - Data to characterize grain-size distribution of substrate material, and to assess the mobility of this material under existing and proposed design conditions.
- Analysis must include verification of capacity of the primary crossing structure to convey flood flows, and may need to include assessment of the need for floodplain continuity to minimize stresses on the primary crossing.
  - Evaluation of the streambed material for stability under design flood flows. Even when a structure spans the streambed and banks, it may constrict flows during flood events. The designer should evaluate whether the streambed material will be susceptible to displacement by flood flows, and if so, whether natural sediment transport and deposition will replace that material. In some cases, the design may need to provide for a wider span or additional flood conveyance structures to control flood-flow related stresses on the streambed material at the crossing. The designer also needs to consider these conditions relative to the design of scour protection for the structure.

#### **Other Factors Affecting Selection and Application of this Design Approach**

- If warranted by analysis, provide floodplain continuity (relief culverts or other measures) to convey flood flows in a manner that maintains stability of the channel beneath the bridge.
- There are limits on the length of span that can be used for various types of bridges, as specified in the MassDOT *Bridge Manual*. Where the required span width (1.2 times bankfull width of river or stream) exceeds this limit, then a clear span would not be feasible. In this case, intermediate piers would be required to support a crossing structure, and these piers may need to be constructed in the active stream channel. In such a case, the designer should coordinate with affected regulatory agencies regarding the crossing design, and work with those agencies during the “design development” phase to develop a crossing configuration that meets structural requirements, while resulting in the least impact on river and floodplain hydraulic, geologic, and ecological processes.

#### **Reference Documents**

MassDOT. 2006. Project Development and Design Guide. Massachusetts Executive Office of Transportation. Boston, Massachusetts.

- Chapter 8 - Drainage and Erosion Control
- Chapter 10 – Bridges

MassDOT. 2006. 2005 Edition Bridge Design Manual, Parts I and II. Massachusetts Executive Office of Transportation. Boston, Massachusetts

### 4.2.3 Stream Simulation

#### Characteristics

Stream Simulation design<sup>29</sup> comprises a technique in which the culvert or bridge crossing is constructed with an integral, naturalized stream channel within the structure. The approach is intended to mimic the natural stream processes within the structure.

The culvert or bridge opening is sized to meet or exceed the width specified in the Massachusetts River and Stream Crossing Standards. A streambed is constructed within the structure based on a geomorphologic evaluation of the existing streambed near or at the crossing, or a comparable “reference stream”. A “reference stream” consists of a stream reach with a drainage area, slope, and morphology similar to the proposed section of constructed streambed.

A culvert or bridge that is designed by the Stream Simulation technique maintains continuity of natural stream processes, including sediment transport, flood debris passage, fish passage, and the movement of other aquatic wildlife. A Stream Simulation culvert can be designed with an openness value meeting the requirements of the River and Stream Crossing Standards, and thus fully meet those Standards.

The Forest Service Stream Simulation Working Group (2008) describes this design method in detail. If the structure is a culvert, the design calls for embedding the bottom of the culvert below the channel invert of the stream. If the structure is a bridge or “bottomless culvert”, then the design provides for a constructed stream channel with an invert that blends into the natural upstream and downstream channel. This invert is determined based on an analysis of the longitudinal profile of the thalweg of the streambed (sometimes referred to as the “long profile”). The analysis considers not only the existing vertical alignment, but also the potential for channel adjustment (aggradation or degradation) as indicated by the bed forms and natural grade control features along the channel. The designer determines the profile of the constructed streambed, and then establishes the structure embedment (or depth of bridge or arch foundation). In the case of an enclosed conduit, the culvert would be embedded typically 30 to 50% of its rise.

A stream channel is designed for the interior of the crossing structure based on the characteristics of the approaching channel or suitable reference stream. The channel is constructed with bed forms and materials that are closely similar to the stream being bridged. For reasonable stability, the bedding material may be somewhat larger in typical dimension than the nearby stream, but should be within the naturally occurring range of material size in the existing watercourse.

The designer must conduct a hydraulic analysis of the culvert or bridge with the proposed streambed material, to verify that the capacity of the structure is sufficient to convey the design flood. The size of the

---

<sup>29</sup> Stream Simulation design for culverts and bridges is an evolving technology, with continuing development of new reference materials. At the time of publishing of this handbook, the Federal Highway Administration has just published *Hydraulic Engineering Circular 26: Culvert Design for Aquatic Organism Passage* (Kilgore, 2010), which provides a detailed methodology for designing culverts based on the Stream Simulation approach. Designers should consult that document, as well as others cited herein, for guidance on this approach. MassDOT anticipates future updates of this handbook will more fully integrate the methodology outlined in HEC 26.



structure opening can be increased if needed to accommodate design flows, or “relief culverts” can be added within the active floodplain of the stream.

In addition, the designer must conduct an analysis of the bed material for sustainability. In a stream with a gradient generally less than 4%, the bed material design uses a series of rock bands; these structural elements of the bed are not mobile. Finer materials between these structural elements consist of smaller materials (these can range from smaller boulders to fine-grained materials, selected based on particle size and gradation analyses of the adjacent streambed or reference stream). The finer materials may move with bed load during flood events and be replaced by recruitment. The rock material used for the structural bed forms (rock bands) helps stabilize the general shape of the channel. The rock band material should be assessed for stability under flood flow conditions, and the size of stone should be adjusted according to this analysis. Measures for “floodplain continuity” may also need to be considered to avoid hydraulic conditions that would displace the rock bands.

“Floodplain continuity” consists of the provision of conveyance capacity within the floodplain to augment the capacity of the primary crossing. Additional capacity can be provided by relief culverts, roadway embankment sections that permit overflow during flood events, or other measures to convey flood flows by alternative channels around the primary bridge or culvert. Such flood conveyance measures may lessen the extreme flow, depth, and velocity conditions at the culvert or bridge opening, providing for less potential for scour at inlet, outlet, and within the confines of the structure.

In steeper gradient systems (greater than 4% gradient), the bed material consists of engineered or native material placed throughout the length of structure, without the use of the “rock band” bed-control structures. In these steeper structures, the bed materials (dominated by cobbles and boulders) are very coarse and stable with the largest particles interlocking to form a network of continuous support along the length and depth of the fill.

### **Conditions where applicable**

- New and replacement crossings with culverts where it is feasible to fully meet the Stream Crossing Standards but where a bridge span is not feasible.
- Replacement crossings using bridge spans, bottomless arch and three-sided box culverts, where the replacement requires constructing a new channel (*e.g.*, where an existing crossing consists of a culvert, a bridge or arch span may be used, but there is no existing stream channel within the limits of the previous structure).
- New crossings using bridge spans, bottomless arches, or three-sided box culverts, where it is necessary to reconstruct or restore an existing stream channel. For example, an existing stream may have been previously altered by historic activity, and requires restoration at the site of the proposed new crossing. (Otherwise, such crossings should bridge the existing channel without disturbance; see “Stream Span” design approach.)
- In locations where the natural channel gradient is moderate to high and the culvert length is great.
- In locations where the stream valley is narrow.

- This approach generally applies to culverts where invert slopes are less than or equal to 6%. Greater gradients may be considered, but may require use of retention sills to prevent the loss of substrate during flood events.
- Generally, this design approach applies when culverts are installed at the same gradient as the approaching upstream channel. Stream Simulation culverts can be used with slopes up to 125% of the upstream bed slope, but require careful analysis of the stability of the proposed bed material.
- See Forest Service Stream Simulation Working Group (2008) for further guidance on the applicability of this design approach.

### Schematic Illustration

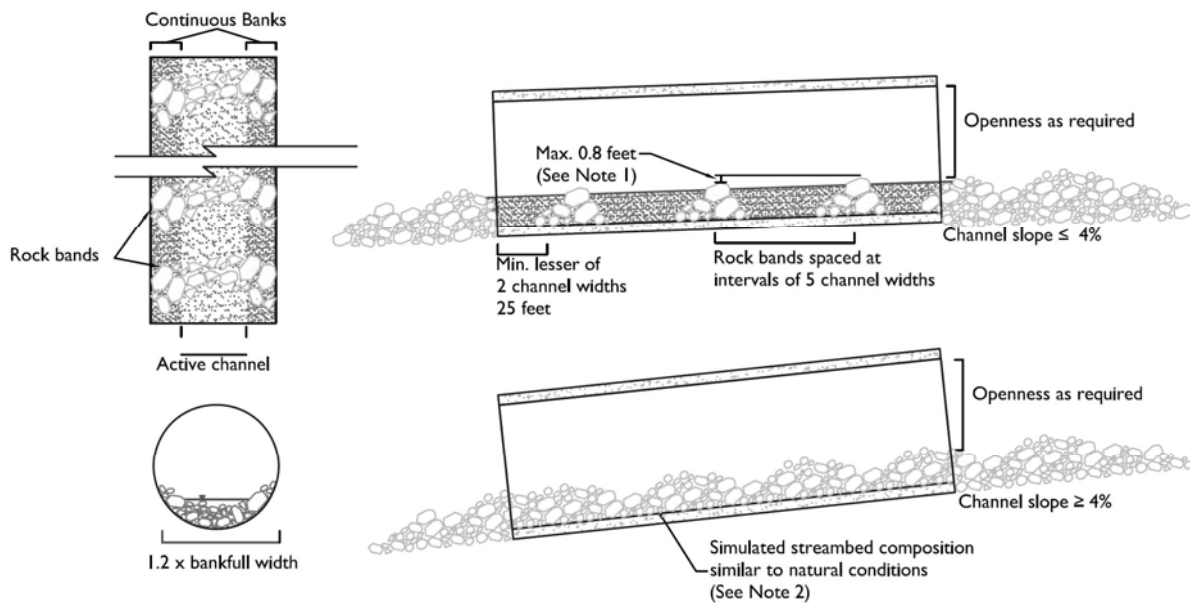

**Notes:**

1. If the vertical drop between rock bands is greater than 0.8 feet, decrease the interval between bands to less than 5 channel widths.
2. Retention sills may be needed to stabilize the bed material at grades greater than 6 percent.

**Figure 4-5. Stream Simulation**

### Information required for design

- All information typically required for design of MassDOT bridges and culverts
- An evaluation of the valley bedrock structure and surficial geology to the extent practicable.
- Longitudinal profile of the streambed along its thalweg for sufficient distance upstream and downstream of the culvert, to enable determination of the long-term likely stream profile through the crossing structure. An assessment should be made of existing and natural features that may

affect future channel vertical alignment. This includes an analysis of natural bed forms as revealed by the long profile, assessment of the presence of rock outcrops that may control head-cutting, and assessment of other structures on the water course that could affect aggradation or degradation of the streambed.

- Geomorphologic characterization of a reference streambed at equilibrium with current hydrologic and hydraulic conditions, including:
  - bankfull width, depth, and corresponding discharge;
  - slope of the reference channel streambed
  - bed material grain size distribution
- Analysis must include evaluation of designed bed material for stability under design flows, including flood flows. In some cases, the design may need to provide for flood relief culverts or alternative flood conveyance measures, to control flood-flow related stresses on the streambed material at the crossing. For open-bottom structures, the designer also needs to consider these conditions relative to the design of scour protection for the structure.
- Analysis must include verification of capacity of the primary crossing structure to convey flood flows, and may need to include assessment of the need for floodplain continuity to minimize stresses on the primary crossing.
- Design of the material for the simulated streambed must provide for sufficient fine materials to prevent interstitial flow conditions during low flows.

#### **Other factors affecting selection and application of this design approach**

- To integrate the constructed channel within the crossing with the natural channel, the limit of work may need to extend upstream or downstream for some distance. This could require work beyond the limits of existing right-of-way, and may require easements for implementation.
- Floodplain continuity in the form of relief culverts or other measures may be necessary to maintain the stability of the simulated streambed within the culvert under flood conditions.
- Particular care is required where crossings will be installed on incised channels. These watercourses appear artificially narrow and are likely to widen as the channel approaches hydrologic and hydraulic equilibrium. Such lateral channel adjustment needs to be considered in the crossing design.
- The crossing must be designed to avoid changes in flow regime inside the structure and at outlet. Severe flow constriction or hydraulic drops at the inlet can also be problematic.
- The bridge or culvert must provide passage for natural debris.

- The bridge or culvert may need wing walls and headwalls to reduce the potential for scour at the inlet.
- For replacement projects, the Stream Simulation design crossing structure might have a greater hydraulic capacity for passing flood flows than the existing bridge or culvert. Preliminary hydraulic analyses of the replacement structure must consider the possibility of head-cutting of the channel upstream of the crossing. Development of a channel invert through the crossing, which is at a lower elevation than the upstream channel may result in unintended alteration of the hydrology of wetlands located upstream of the culvert. The increase in hydraulic capacity may also alter the flood profile of the stream in the channel downstream of the culvert. Potential changes in hydraulics and flood profile should be assessed during early phases of structure selection and design.

### Reference Documents

Forest Service Stream-Simulation Working Group. 2008. *Stream Simulation: An Ecological Approach to Providing Passage for Aquatic Organisms at Road-Stream Crossings*. USDA Forest Service National Technology and Development Program. (0877 1801-SDTDC)  
<http://www.fs.fed.us/eng/pubs/pdf/StreamSimulation/index.shtml>

Bates, Ken, et.al. 2003. *Design of Road Culverts for Fish Passage*. Washington Department of Fish and Wildlife. Olympia, Washington. Chapter 6.

VDFW. 2005. *Interim Guidelines for Aquatic Organism Passage through Stream Crossing Structures in Vermont*. Vermont Department of Fish and Wildlife. Montpelier, Vermont.

#### 4.2.4 No-Slope Culvert

##### Characteristics

The “No-Slope Culvert” design is a special type of embedded culvert, with features intended to comply with the Massachusetts River and Stream Crossing Standards. A No-Slope Culvert consists of a typical box, arch, or pipe culvert installed with an invert slope of zero percent, embedded as specified below. For the purposes of this guidance document, the No-Slope design also requires the culvert width to equal or exceed 1.2 times the bankfull channel width, and the flow area to comply with the openness value specified by the Standards. Also, for purposes of this Handbook, MassDOT considers the “No-Slope Culvert” as the design approach acceptable where the ACOE’s Massachusetts General Permit indicates that a “Low-Slope Culvert” may be used.

Where a clear-span bridge or bottomless culvert design cannot be used, a No-Slope Culvert can meet or exceed the Stream Crossing Standards.

The culvert must be embedded in the channel bottom according to the following criteria:

- The downstream invert must be countersunk below the ambient channel bed by a depth greater than or equal to the following:
  - Two feet or 20 percent of the rise (the total interior dimension from floor to top), whichever is greater, for box culverts and for other culverts with smooth interior walls;
  - One foot or 20 percent of the rise (whichever is greater) for corrugated pipe arches
  - One foot or 25 percent of the diameter (whichever is greater) for corrugated circular pipe culverts.
- The upstream invert must be countersunk below the ambient channel bed by a depth no greater than 40 percent of the rise for box and arch culverts or 40 percent of the diameter for round pipe culverts.
- The openness value measured at the upstream limit of the culvert must be greater than or equal to 0.82 feet (0.25 meters) if “General Standards” apply, or the greater openness value specified when “Optimum Standards” apply.

##### Conditions where applicable

The No-Slope Culvert design is applicable for new and replacement culverts at sites where the natural streambed has a gentle to moderate slope. Guidance suggests that suitable locations will have a natural gradient of less than or equal to 3 percent.

The minimum outlet embedment and maximum inlet embedment will also limit the length of a culvert that can be used, depending on its vertical interior dimension. For box culverts and pipe arches, the product of the channel slope (feet/foot) and the culvert length (feet) will not exceed 20 percent of the

culvert rise (feet). For corrugated circular pipes, the product of slope times length will not exceed 15% of the diameter.

Proper design and construction will allow for the natural movement of streambed materials within the culvert, eliminating physical barriers for aquatic species. This type of culvert is most likely applicable for streams with relatively fine-grained, mobile bed material.

This type of culvert installation may be particularly appropriate for tidal rivers and streams, where the bed material consists of fine-grained marine deposits.

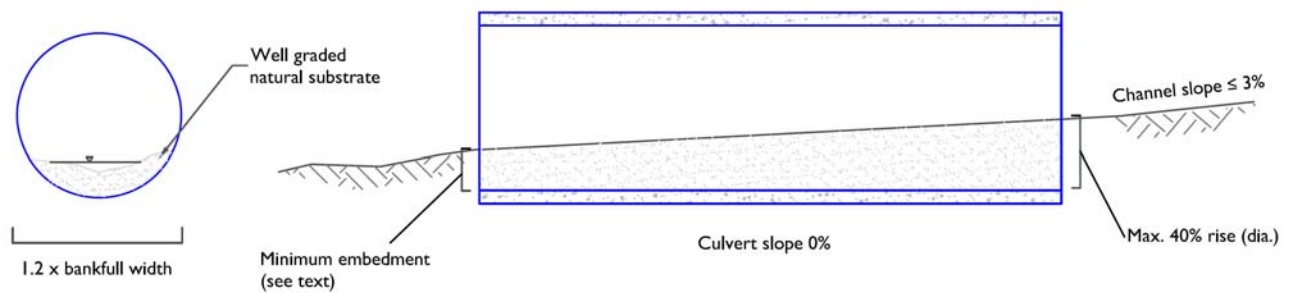

**Figure 4-6. No-Slope Culvert**

#### Information required for design

- All information typically required for design of MassDOT bridges and culverts;
- The bankfull width, depth, and corresponding discharge of the natural stream channel;
- The longitudinal profile of the streambed extending a sufficient distance upstream and downstream of the structure location to enable determining the potential for vertical channel adjustment of the stream. The embedded depth of the culvert should be based on an estimate of the long-term adjustment of this stream profile;
- An assessment of the mobility of the natural stream substrate, and the ability of the installed culvert invert to recruit bed material from the natural sediment bed load moving along the stream.

#### Other factors affecting selection and application of this design approach

- For replacement projects, the No-Slope Culvert may have a greater hydraulic capacity for passing flood flows than the existing culvert. Preliminary hydraulic analyses of the replacement culvert

must consider the possibility of head-cutting of the channel upstream of the culvert. Placement of the culvert invert at a lower elevation than the upstream channel may result in head cutting and/or in the unintended alteration of the hydrology of wetlands located upstream of the culvert. The increase in hydraulic capacity may also alter the flood profile of the stream in the channel downstream of the culvert. Potential changes in hydraulics and flood profile should be assessed during early phases of structure selection and design.

#### **Reference Documents**

Bates, Ken, et.al. 2003. *Design of Road Culverts for Fish Passage*. Washington Department of Fish and Wildlife. Olympia, Washington. (Refer to Chapter 4.)

VDFW. 2005. *Interim Guidelines for Aquatic Organism Passage through Stream Crossing Structures in Vermont*. Vermont Department of Fish and Wildlife. Montpelier, Vermont.

## 4.2.5 Bridge Replacement with Retained Abutments

### Characteristics

Bridge Replacement with Retained Abutments involves the construction of a new bridge structure founded on new abutments installed on the upland side of the existing bridge abutments. The existing abutments serve as coffer dams during construction. These abutments are kept in place permanently, but the tops of them are removed to provide clearance for the new bridge structural elements. The shortened abutments provide long-term scour protection for the new bridge foundation. Generally, this design approach allows constructing the bridge replacement without performing work within the active stream channel. This alternative is well suited to the replacement of a bridge span where

- the channel bed material beneath the bridge is either stable or sustained by natural sediment transport and deposition, and
- the structure and bed material currently present little or no obstruction to aquatic organism movement within the limits of the active channel, even though the span may not equal that specified by the Massachusetts Stream Crossing Standards.

During the course of installation of the new bridge structure, the old abutments can be shortened, providing the following benefits:

- The finished surface of the shortened abutments can be set at a height enabling inspection of the underside of the bridge structure;
- The “overbank” area provided by the shortened abutments can provide additional flow capacity beneath the bridge during flood flow conditions;
- Through thoughtful design, the finished surface of the shortened abutments can be blended into the upstream and downstream banks, providing a pathway for terrestrial passage by wildlife. The designer should consider setting the elevation of this finished surface at approximately bankfull stage.

Bridge Replacement with Retained Abutments structures should be designed in accordance with MassDOT standard practices as set forth in the references cited below. As required by such design practice, the engineer needs to evaluate and design for scour protection for bridge piers and abutments.

Measures should be taken during construction to protect the existing stream, consistent with the Construction Best Management Practices described in the River and Stream Crossing Standards. Generally, the Integral Abutment Replacement design approach should generally not require working within the active stream channel, and require no special measures for handling in-stream flows during construction.

Major advantages of this type of structure include:

- This design approach can provide a cost-effective replacement structure where existing aquatic habitat continuity is in good condition. While the alternative may not provide the full span of 1.2



times bankfull channel, it can still meet most other Stream Crossing Standards. Modification of the old abutments to blend into the existing stream banks may also provide some degree of terrestrial wildlife accommodation, as well.

- The construction process can easily maintain stream flows during installation, as the existing abutments can be used as temporary works instead of requiring new coffer dams;
- The use of the existing bridge structure during the construction process can shorten the construction period, reducing the length of time of other temporary environmental impacts associated with construction.

Potential disadvantages of this type of design include the following:

- This design approach is less preferred than a clear span, with no structures encroaching toward or into the natural channel. From a fisheries and geomorphic perspective, removing all structures in the active channel is more beneficial than retaining the old abutments.
- This method will not correct existing channel obstructions that exist at the bridge crossing, including existing vertical drops or possible barrier effects due to high velocities or turbulence (where the bridge opening is considerably narrower than the existing stream channel).
- In cases where the existing bridge constricts the channel, the reconstructed structure is likely to continue to inhibit the natural transport of sediment and debris.
- Depending on the elevation of the retained abutments, they may present a navigational hazard.

### **Conditions Where Applicable**

This method is applicable only to replacement of existing bridges. The Integral Abutment design may apply to the following:

- Replacement structures within the same general alignment as the existing structure, where the length of resulting bridge span is within the limits for type of structure as indicated in the MassDOT Bridge Design Manual.
- Replacement structures for bridges that reasonably accommodate the movement of aquatic organisms within the current bridged stream. If the existing bridge presents a significant obstruction to existing aquatic wildlife passage (other than a condition that may have existed prior to the bridge; e.g., a natural fall), then alternative designs should be considered to correct such obstruction.

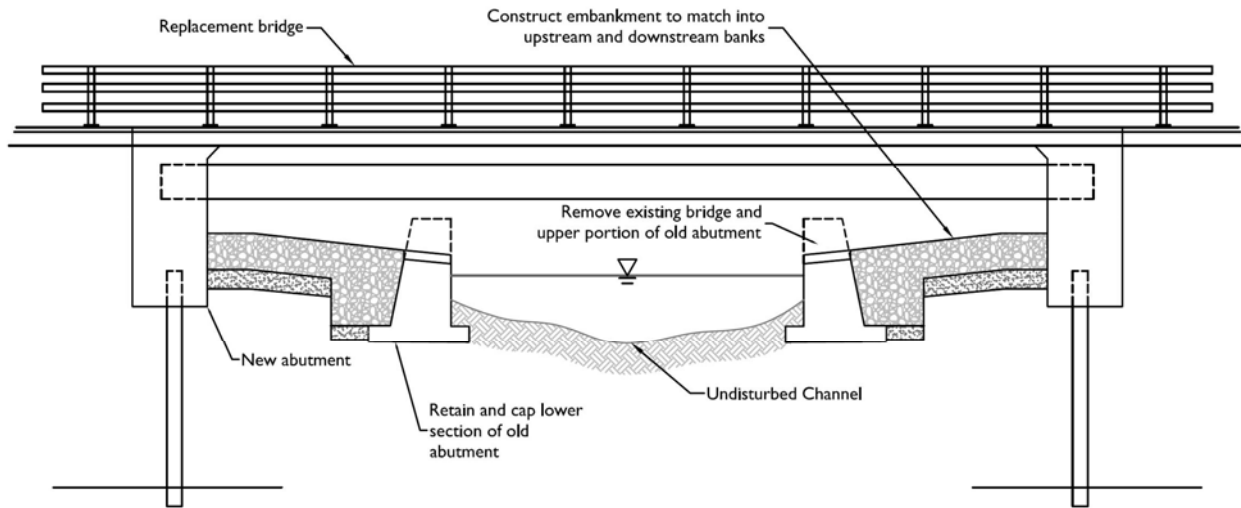

**Figure 4-7. Bridge Replacement with Retained Abutments**

#### Information required for design

- All information typically required for design of MassDOT bridges and culverts;
- The bankfull width of the natural stream channel;
- Field verification that under existing conditions, the streambed at the bridge crossing is either stable or sustained by normal stream sediment transport and deposition processes.

#### Other factors affecting selection and application of this design approach

- There are limits on the length of span that can be used for various types of bridges, as specified in the MassDOT *Bridge Manual*. Where the required span width would exceed this limit for an integral abutment replacement design, then alternative types of crossings may need to be considered. Alternatives that might be considered include, but are not limited to:
  - Replacement of abutments in-place to provide for a shorter bridge span (in which case, the replacement may require temporary disturbance within the stream channel);
  - Integral abutment replacement with mid-channel bridge piers (the designer should conduct early coordination with natural resource agencies to determine acceptable pier configuration). This alternative would require work in the active stream channel.
  - Replacement of the bridge with an embedded multiple-box culvert. This alternative requires providing streambed material within the culvert box. It also requires work in the active channel.

- Each of these alternatives would only partially comply with the Stream Crossing Standards, without the advantage of avoiding construction work in the active stream channel.

### **Reference Documents**

MassDOT. 2006. Project Development and Design Guide. Massachusetts Executive Office of Transportation. Boston, Massachusetts.

- Chapter 8 - Drainage and Erosion Control
- Chapter 10 – Bridges

MassDOT. 2006. 2005 Edition Bridge Design Manual, Parts I and II. Massachusetts Executive Office of Transportation. Boston, Massachusetts.

## 4.2.6 Full Span Embedded Multiple-Box Culvert

### Characteristics

The Full Span Embedded Multiple-Box Culvert consists of two or more box culverts installed with an overall width equal to or exceeding 1.2 times the bankfull width of the stream. The inverts of the culverts are countersunk below the channel invert, allowing for the placement or natural accumulation of streambed material within the culvert. At least one of the culverts is designed to provide the openness requirement specified by the Massachusetts Stream Crossing Standards.

The hydraulic capacity of the embedded culvert is evaluated based on the available flow area (deducting the embedded portion of the culvert from the cross sectional area of the culvert), with roughness based on the substrate material. Flow capacity and structural requirements are determined in accordance with standard practices for Flow Conveyance Design. Conventional design practices also include provision of scour protection and for flow transitions at inlet and outlet, as for Flow Conveyance Design.

In some cases, embedded multiple box culverts can be installed with the invert depressed below the adjacent streambed, but without the engineered placement of substrate within the structure at the time of installation. Instead, the invert of the culvert is allowed to fill naturally, as a result of bed load movement through the structure. This process is referred to as “substrate recruitment”. The design of these types of multiple box culverts should follow the guidelines for “No-Slope Culverts” described in this guidance.

This type of multiple box culvert should be designed following the guidance for “Roughened Channel Embedded Culverts.” Streambed material within the culvert must be stable under the full range of flow conditions for which the culvert is designed. For this case, the engineered geometry of the streambed material should provide for a low flow channel in one of the culvert barrels.

A properly designed Full Span Embedded Multiple Box Culvert should be able to accommodate bankfull flows with velocities and depths comparable to the existing stream channel, allow for terrestrial passage at less than bankfull flows, provide for continuity of streambed materials, and meet openness requirements of the Stream Crossing Standards.

Major advantages of this type of structure include:

- The construction process can easily maintain stream flows during installation of the culvert barrels. One of the barrels can be installed while flow is maintained in part of the adjacent channel. The stream flow can then be directed to the newly installed barrel, and the remaining barrel(s) installed.
- The available sizes of pre-cast box units and the use of multiple units allows flexibility in the replacement of existing structures, where vertical and horizontal clearances affect practical span widths, hydraulic openings and other aspects of the design.

Potential disadvantages of this type of design include the following:

- Multiple barrel structures are more susceptible to clogging by natural or urban debris than clear span structures.
- The wall between adjacent culvert barrels can interfere with the normal three-dimensional flow regime of the stream and the associated sediment transport processes. Thus, the shape and composition of the streambed within the culvert may not be as sustainable over the long term as would be the case for a clear span design. For example, because of the barrier to lateral flow of water and sediment, in cases where the stream bed is highly mobile or the stream carries a high sediment load, one of the barrels might become completely scoured of the bed material while adjacent barrels become clogged with sediment. In some cases, measures may be incorporated into the approach channel to minimize this condition; for example, the designer could consider in-stream features such as rock weirs or “W-weirs” (see MDEWMA, 2000) to distribute flows across the inlet of the structure.
- Because of these conditions, scour at inlet or outlet of the culvert may result in alterations of the upstream or downstream channel.

### Conditions Where Applicable

This method is applicable to enclosed culverts, but not bottomless culverts or bridges. Full-span bridges or full span single-barrel culverts are preferred where practicable. Applicability of this design approach therefore includes:

- Replacement crossings where the installation cannot accommodate a clear span of 1.2 times bankfull width, but can provide this overall span with a multiple box culvert. In this case, at least one of the culvert barrels should meet the required openness value (see Figure 4-8). The design of all barrels should provide a sustainable substrate by applying principles of either No-Slope Culvert or Roughened Channel Embedded Culvert design (see Section 4.2.7).
- The design may be particularly useful for replacement of structures where vertical clearances limit the use of clear spans, because of the required vertical dimension of such a span. In this case, the roof thickness of a multiple-box culvert may offer the means to provide the overall hydraulic opening required.

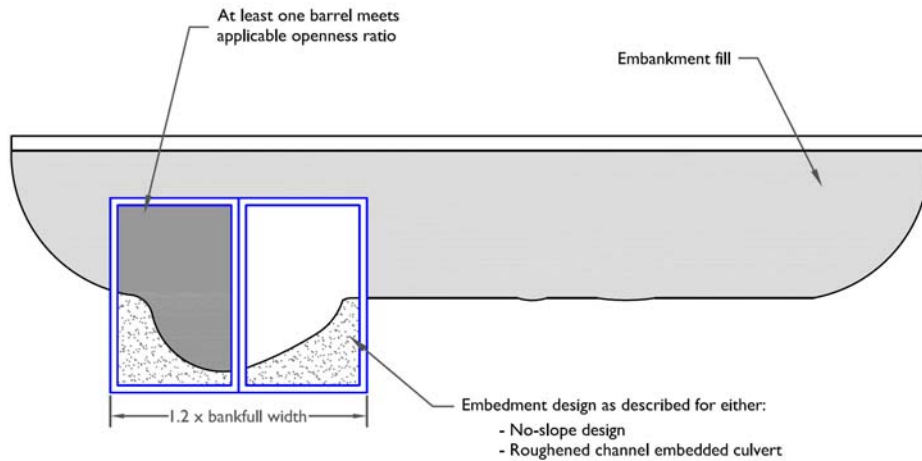

**Figure 4-8. Full Span Embedded Multiple-Box Culvert**

Note that this figure shows the dual box culvert positioned in alignment with the natural channel. However, achieving and sustaining this natural channel geometry within the structure can be problematic. See discussion in the text regarding potential disadvantages of this type of structure.

#### Information required for design

- All information typically required for design of MassDOT bridges and culverts;
- The bankfull width of the natural stream channel;
- The longitudinal profile of the streambed extending a sufficient distance upstream and downstream of the structure location to enable determining the potential for vertical channel adjustment of the stream. The embedded depth of the culvert should be based on an estimate of the long-term adjustment of this stream profile;
- Characterization of the substrate material of the adjacent stream, to determine material for placement in culvert invert. Depending on existing streambed characteristics, this may include an assessment of the mobility of the material, and whether the culvert invert can be allowed to be filled by “recruitment” from normal bed load.

#### Other factors affecting selection and application of this design approach

- Because the common wall between culvert barrels can inhibit natural hydraulic and sediment transport processes, the Full Span Embedded Multiple-Box design may not account for long-term channel adjustment of the approaching and departing stream. The design will need to consider whether upstream and downstream channel conditions are stable, and whether existing or proposed in-stream grade control will limit the change in vertical channel profile over the life of the culvert.

- The design must consider the potential for scour at the outlet of the culvert, scour and sediment deposition within the individual barrels, and potential inlet clogging by debris.
- Flood flow conditions may scour bed materials from within the culvert. The designer should evaluate the potential for natural recruitment of fines to replace material likely to be eroded during flood flows; alternatively, the designer could consider provision of floodplain continuity (e.g., floodplain relief culverts).
- Selection of culvert size must consider space needed to place the bed material within the culvert barrel during construction;
- Bed retention sills may be necessary on steeper culverts (> 6% gradient), to retain the bed material within the culvert. Note, however, that bed retention sills can also become barriers to certain species. Stream flows in these steep-gradient conditions often erodes material retained by the sills, exposing these structural elements that then become barriers to aquatic organism movement.

#### Reference Documents

Bates, Ken, et.al. 2003. *Design of Road Culverts for Fish Passage*. Washington Department of Fish and Wildlife. Olympia, Washington. (Refer to Chapter 4 for the No Slope Culvert design procedure, Appendix E for the Roughened Channel Design procedure, and to Chapter 6 for design of well-graded bed material mixtures.)

MDEWMA 2000. *Maryland's Waterway Construction Guidelines*. Maryland Department of the Environment Water Management Administration. Baltimore, Maryland.

VDFW. 2005. *Interim Guidelines for Aquatic Organism Passage through Stream Crossing Structures in Vermont*. Vermont Department of Fish and Wildlife. Montpelier, Vermont.

#### 4.2.7 Roughened Channel Embedded Culvert

##### Characteristics

The Roughened Channel Embedded Culvert is culvert that may have a lesser width than specified by the Massachusetts Stream Crossing Standards, but has an engineered bed material designed to resist displacement from the culvert, prevent “subsurface flow,” and in some cases provide hydraulic conditions suitable for passage of specific fish species.

Subsurface flow is a condition where flow through the culvert during low flow periods occurs within the void spaces in the substrate, as might occur through coarse material such as riprap. The Roughened Channel Design procedure involves the sizing and gradation of material to sustain surface flow through the culvert, while meeting stability requirements.

The culvert itself consists of a typical box, arch, or pipe culvert installed at a slope equal to that of the natural streambed and countersunk below the channel invert. Roughened Channel design incorporates specifically designed, stable bedding within the structure. Some natural recruitment of fine materials may occur, but the primary stone material provided for substrate is intended to be structurally stable under anticipated flow conditions.

This type of embedded culvert is typically designed so that the hydraulic opening is equivalent to that required for either “Flow Conveyance Design” or for “Fish Passage Hydraulic Design”. Such a design would not necessarily meet the requirements of the Stream Crossing Standards relative to width and openness. The design can provide for some control of velocities and depths under a variety of flow conditions, depending on the culvert width and slope relative to the upstream and downstream channel.

Depending on the width and slope of the culvert, Roughened Channel Design may not avoid or mitigate the following conditions:

- Hydraulic drops associated with the flow transition into the culvert under “inlet control” conditions.
- Physical drops at the inlet and outlet;
- Flow contraction at the inlet;
- Scour pool formation at the outlet;
- Channel degradation downstream of the outlet.

The Roughened Channel design can be used to develop a stable substrate composition that will control the velocity and depth within the culvert, maintaining surface flow for under low flow conditions. In a Roughened Channel Design culvert:

- The bed material is stable, not mobile;



- Surface flow is controlled by designing of the gradation of material used for substrate, to provide sufficient fine-grained materials to prevent interstitial flow (for design procedure for substrate composition, refer to Chapter 6 of the reference document cited below, *Design of Road Culverts for Fish Passage*);
- Velocity is controlled by the roughness of the bed material and the slope of the culvert
- Depth is controlled by shaping of bed material to create a low-flow channel, and placement of bed retention sills to form a series of step-pools within the culvert.

See the design reference below for a full description of the design procedure for Roughened Channel Design.

### Conditions Where Applicable

This method is applicable to enclosed culverts, but not bottomless culverts or bridges. Other methods of crossing design are preferred to Roughened Channel design in order to fully meet the Massachusetts River and Stream Crossing Standards. Applicability of this design approach therefore includes:

- New and replacement crossings, where it is not feasible to fully meet the Stream Crossing Standards but where it is feasible to install a culvert with a stable material within the invert. Ideally, the material should be similar in gradation to that found in the adjacent stream system, or comparable to the larger size material found in the stream system.
- Replacement crossings where the installation cannot accommodate a clear span of 1.2 times bankfull width, but can accommodate a box culvert or similar structure that can meet the required openness value and provide a stable substrate.
- This approach may be appropriate for crossings at moderate to high channel slopes or along sections of over-steepened channel.
- This approach is not recommended for replacement crossings in low gradient streams with relatively mobile bed materials. In these settings, consider designs that allow replacement of bed material lost by scour during high-flow conditions to be naturally replaced by the movement of sediment through the system. Preferably, the designer should consider the “No Slope” or Stream Simulation design options.
- Roughened Channel design may not account for long-term vertical channel adjustment. Hydraulic conditions at the outlet may result in long-term downstream channel adjustment. This approach should generally be limited to use in areas where upstream and downstream channel conditions are stable, and where existing grade control will limit the change in vertical channel profile over the life of the culvert. The design must consider the potential for scour at the outlet of the culvert.

### Information required for design

- All information typically required for design of MassDOT bridges and culverts;

- Data on existing streambed material, including grain-size distribution (including boulders and cobbles, as well as finer materials) and assessment of bed mobility.
- Where the culvert will be designed for passage of specific fish species, all data required for “Fish Passage Hydraulic Design” (see Section 4.2.9).

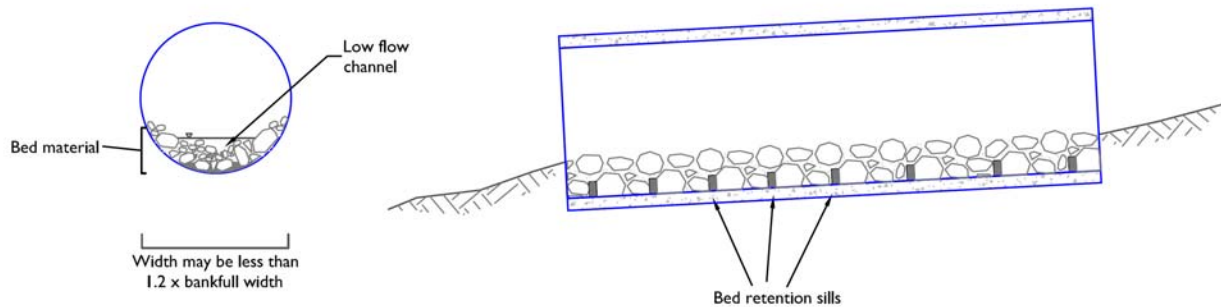

**Figure 4-9. Roughened Channel Embedded Culvert**

#### **Other factors affecting selection and application of this design approach**

- Flood velocities and potential for scour of bed material can be problematic if the width of the culvert is significantly narrower than the stream channel served by the structure;
- Depending on flood flows and the culvert geometry, potential hydraulic conditions may require substrate stone sizes that are too large to be practicable for placement within the culvert;
- Flood flow conditions may scour fine materials from the bed material within the culvert. The designer should evaluate the potential for natural recruitment of fines to replace material likely to be eroded during flood flows;
- Selection of culvert size must consider space needed to place the bed material within the culvert barrel during construction;
- Bed retention sills may be necessary on steeper culverts (> 6% gradient), to retain the bed material within the culvert.

## Reference Documents

Bates, Ken, et.al. 2003. *Design of Road Culverts for Fish Passage*. Washington Department of Fish and Wildlife. Olympia, Washington. (Refer to Appendix E for the Roughened Channel Design procedure and to Chapter 6 for design of well-graded bed material mixtures.)

## 4.2.8 Simple Embedded Culvert

### Characteristics

The Simple Embedded Culvert is a typical box, arch, or pipe culvert installed to maintain the slope of bed material in the culvert equal to that of the natural streambed. The culvert invert is countersunk below the channel invert and the culvert is usually filled with substrate graded to maintain surface flow and provide a stable bed form.

The hydraulic capacity of the embedded culvert is evaluated based on the available flow area (deducting the embedded portion of the culvert from the cross sectional area of the culvert), with roughness based on the substrate material. Flow capacity and structural requirements are determined in accordance with standard practices for Flow Conveyance Design. Conventional design practices also include provision of scour protection and for flow transitions at inlet and outlet, as for Flow Conveyance Design.

In some cases, embedded culverts can be installed with the invert depressed below the adjacent streambed, but without placement of substrate within the structure at the time of installation. Instead, the invert of the culvert is allowed to fill naturally, as a result of bed load movement through the structure. This process is referred to as “substrate recruitment”.

Not all Simple Embedded Culverts will fully meet the River and Stream Crossing Standards. Some embedded culverts are designed so that the hydraulic opening is equivalent to that required for “Flow Conveyance Design”. Such a design would not necessarily meet the requirements of the Standards relative to width, openness, flow velocities, and flow depths. Simple embedment of the culvert may not avoid or mitigate the following conditions:

- Hydraulic drops associated with the flow transition into the culvert under “inlet control” conditions.
- Physical drops at the inlet and outlet;
- Flow contraction at the inlet;
- Scour pool formation at the outlet;
- Channel degradation downstream of the outlet.

One problem with a Simple Embedded Culvert is that the substrate may be subject to movement under flow conditions where the adjacent stream channel is stable. Because of the constricted flow area, higher velocities in the culvert may displace the bed material from within the culvert.

Culverts designed according to the “No-Slope Culvert” and “Stream Simulation” design approaches are special cases of “embedded culverts” but are discussed separately because of their ability to accommodate the full width and stream substrate conditions specified by the Stream Crossing Standards.

## Conditions Where Applicable

This method is applicable to enclosed culverts, but not bottomless culverts or bridges. Other methods of crossing design are preferred to Simple Embedded Culverts in order to fully meet the Massachusetts River and Stream Crossing Standards. Applicability of this design approach therefore includes:

- New and replacement crossings, where it is not feasible to fully meet the Stream Crossing Standards but where it is feasible to install a culvert with a sustainable embedded invert.
- Replacement crossings where the installation cannot accommodate a clear span of 1.2 times bankfull width, but can accommodate a box culvert or similar structure that can meet the required openness value and provide a sustainable substrate (however, the design should consider “Roughed Channel” design in locations where substrate is not normally mobile).
- Replacement crossings where the installation cannot accommodate a clear span of 1.2 times bankfull width, but can provide this overall span with a multiple box culvert or similar structure, where one barrel can meet the required openness value and the structure can provide a sustainable substrate. However, the design should consider “Roughed Channel” design in locations where substrate is not normally mobile.
- Replacement crossings in low gradient, fine-grained streambeds where bed material lost by scour would be naturally replaced by the movement of bed-load through the system. Consideration should be given to installing the culvert in a manner similar to the “No-Slope” design, rather than at the natural stream slope, to enhance the retention of streambed material. However, where the culvert is narrower than the natural channel, normal flows may result in displacement of bed material from the structure even when the upstream and downstream channel bed material is not mobile.
- Simple embedment may not account for long-term channel adjustment. Hydraulic conditions at the outlet may result in long-term downstream channel adjustment. This approach should generally be limited to use in areas where upstream and downstream channel geometries are stable, and where existing grade control will limit the change in vertical channel profile over the life of the culvert.

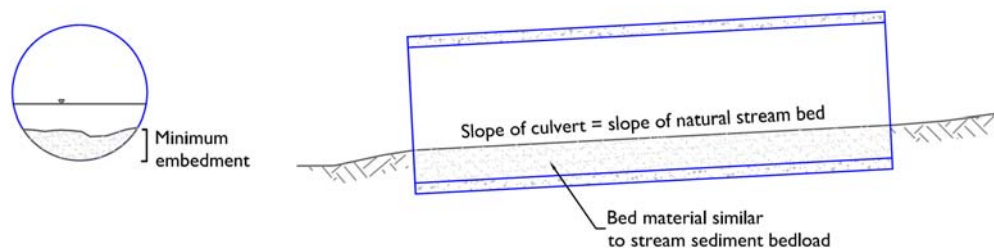

**Figure 4-10. Simple Embedded Culvert**

### **Information required for design**

- All information typically required for design of MassDOT bridges and culverts;
- Longitudinal profile of streambed, with information on vertical channel stability, to enable setting the embedded invert at an elevation that will be sustainable over the life of the culvert;
- Characterization of the substrate material of the adjacent stream, to determine material for placement in culvert invert. This may include an assessment of the mobility of the material, and whether the culvert invert can be allowed to be filled by “recruitment” from normal bed load.

### **Reference Documents**

MDEWMA 2000. Maryland’s Waterway Construction Guidelines. Maryland Department of the Environment Water Management Administration. Baltimore, Maryland.

## 4.2.9 Fish Passage Hydraulic Design

### Characteristics

Fish Passage Hydraulic Design involves the engineering of culverts and, in some cases, bridges to provide for the passage of specific species of fish, usually at specific life stages within those target species. This design approach applies measures to control heights of vertical transitions, flow velocities, and flow depths to within ranges that can be negotiated by the specific fish species. An example is the design of a structure to accommodate river herring, smelt, or salmon during seasonal spawning migration periods.

This method can be of limited value for general stream continuity, as it generally provides for passage for a narrow range of species, and within species a narrow range of swimming/jumping abilities. Examples of structures that provide for hydraulic conditions suitable for fish passage include:

- Low gradient culverts, designed with slopes that accommodate suitable velocities and flow depths for fish passage during low flows and flows associated with migration periods;
- Culverts with baffles, designed to introduce roughness or to alter flow regime within the culvert, thus controlling velocities and depths to specified ranges;
- Some embedded culverts (particularly, those incorporating “roughened channel design”), if designed to control depths and velocities of flow: and
- Bridges or large culverts that are retrofitted with fishways (*e.g.*, “fish ladders”), which are structures specifically designed to be hydraulically negotiable by target fish species.

In all of these approaches, the structures are designed so that flow velocities and vertical drops during specific periods of migration are compatible with the physical swimming and endurance abilities of the target fish species.

Vertical drops can also be avoided or minimized by embedding the culvert vertically within the streambed, with or without the addition of stream substrate to the culvert invert (depending on whether the culvert uses baffles or streambed materials in the design). Vertical drops may also be addressed by incorporating outlet treatments into the design of the downstream channel. This involves introducing weirs or other hydraulic structures into the downstream channel, to maintain a tailwater depth for the range of design flows specific to the migration of the target species. Similar structures may also be necessary in the upstream channel to provide for transition of hydraulic grade changes where the flow enters the culvert. Rock weirs, rock “riffle” structures, and fish ladder structures can be employed for such treatment.

When natural streambed materials are used within the culvert or for upstream and downstream channel transitions, the large bed material must be designed to remain stable. If the bed design includes finer materials, the design must address the potential mobility of these materials. Depending on the normal sediment load of the existing stream, the fine materials displaced from the culvert and transition structures during high flows may be replaced by sediment from the natural bedload of the stream, a process referred to as recruitment. However, long-term retention of fine material may require monitoring and artificial replacement if scour occurs during periods of flood flows, and the hydraulic and sediment transport conditions preclude natural recruitment.

Fish Passage Hydraulic Design may be used to retrofit existing culverts. Retrofit treatments may include grade control of the streambed both upstream and downstream of the crossing and the addition of structural appurtenances including baffles, weirs, and fish ladders. Appurtenances may be combined to result in a crossing that eliminates the velocity, depth, and vertical discontinuity barriers specific to the target species.

A new culvert designed according to the Fish Passage Hydraulic Design must also provide adequate hydraulic capacity for flood events. However, if an existing culvert or bridge is retrofitted with devices such as baffles or weirs, the hydraulic capacity may be reduced, because of the reduced flow area and increased roughness caused by these elements. Hydraulic analysis should be performed to determine if the hydraulic capacity of the modified culvert will be sufficient to safely pass the design flood.

### **Conditions Where Applicable**

This method is most applicable to enclosed culverts, with only limited application to bottomless culverts or bridges (*e.g.*, retrofitting with internal fishways). Other methods of crossing design are preferred to “Fish Passage Hydraulic Design” in order to fully meet the Massachusetts River and Stream Crossing Standards. Applicability of this design approach therefore includes:

- Reconstruction and replacement crossings where it is not feasible to fully meet the Massachusetts River and Stream Crossing Standards, and where the movement of specific fish species needs to be addressed.
- Retrofits of existing culvert and bridge crossings to improve fish passage for specific species, where reconstruction is not otherwise required or feasible, and where the retrofit will not adversely affect hydraulic capacity or structural integrity of the affected crossing.
- Low to moderate slopes (less than 3%) without baffles;
- Moderate to steep slopes (up to 8%) with baffles (or equivalent structural elements).

### **Information Required for Design**

- All information typically required for design of MassDOT bridges and culverts;
- Consultation with MA Department of Fish and Game and other affected agencies, to verify the species of fish that will be addressed by the structure, and to establish the design criteria for passage for the target species.
- Data on the swimming ability and the behavior of the particular fish or other species for which passage will be required. Typical data requirements include:
  - Minimum depths of channel flow negotiable by the target species;
  - Maximum height of pool to pool elevation change at any drop (or jump). Also, information is needed on depth of pool required at the bottom of an obstruction to enable the target fish to leap to the upstream pool;



- Maximum velocity/endurance data for the swimming organism at the life-stage of migration;
- Discharge/frequency data for the stream to determine the range of design flows occurring during the calendar period of target species migration. Usually, low passage flow conditions and high passage flow conditions must be identified;
- Profile of the streambed upstream and downstream of the crossing structure, for a sufficient distance to show the location of other vertical changes in channel gradient that could be affected by the hydraulics of the proposed crossing;
- The water surface profile of the stream for the range of design flows;
- For retrofits, information on the structural condition of the existing crossing and its ability to be modified to provide fish passage structural elements. For example, if the design contemplates the provision of baffles within an existing culvert, then the designer will need information on whether the culvert is structurally compatible with the attachment of baffles.

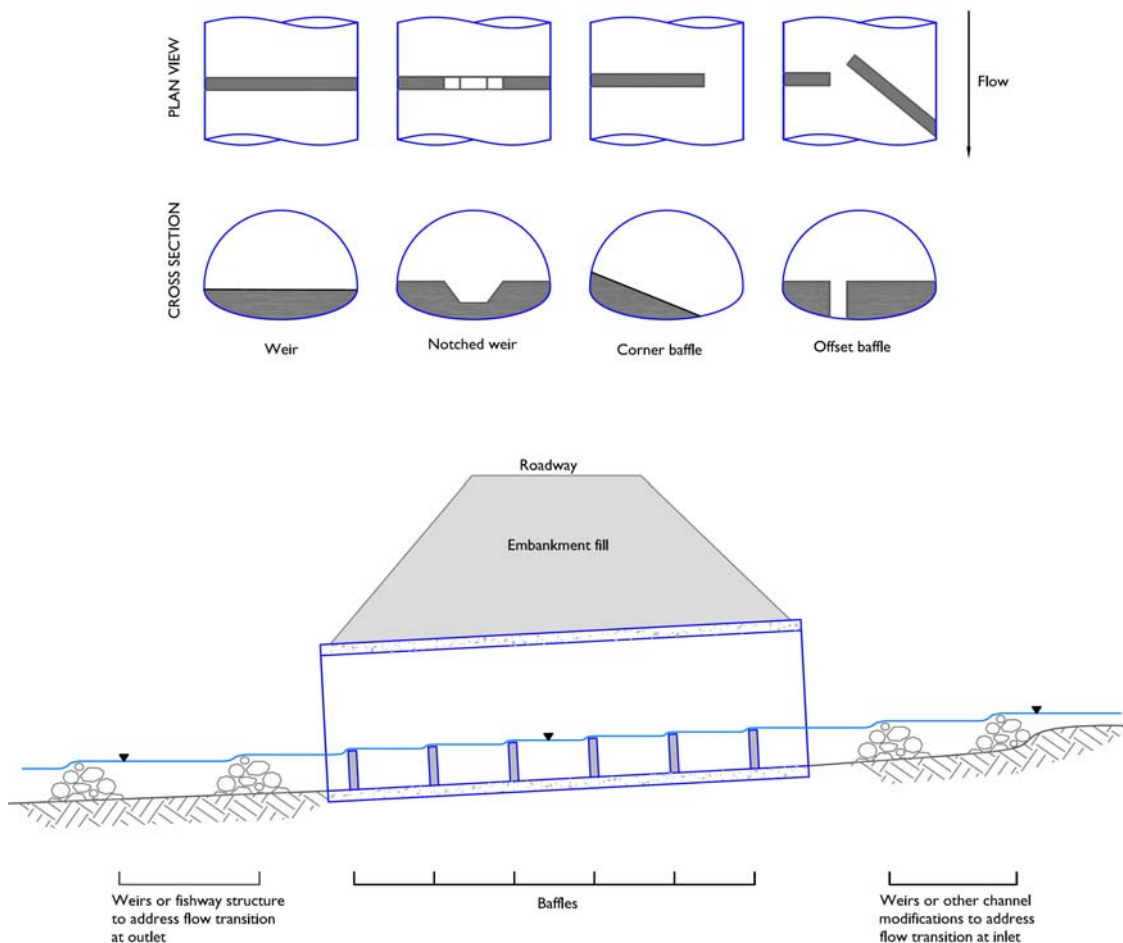

**Figure 4-11. Fish Passage Hydraulic Design**

### Other Factors Affecting Selection and Application of this Design Approach

- Work may extend beyond the existing right-of-way, especially in cases where treatments of the streambed at the inlet and outlet are necessary to achieve suitable hydraulic conditions compatible with the flow conditions within the structure.
- A culvert retrofitted with the fish passage design treatments may no longer be sufficient to pass the design flood; hydraulic capacity of the modified structure should be verified.
- Hydraulic analysis for this design option over the range of required fish passage flows should include verification that the following conditions do not occur:
  - Supercritical flow;
  - Hydraulic jumps within the structure;
  - Abrupt changes in water elevation and the inlet and outlet;
  - Highly turbulent conditions throughout the culvert and the approach and discharge channel.
- The design should consider the passage of debris and sediment under normal flows and during flood events. There is a risk of debris accumulation within an individual “baffled” culvert, which could result in partially or completely blocking the structure’s flood conveyance. For this reason, the design should consider how the structure will perform if the baffles trap debris. One approach would be to design “baffled” fish passage culverts as multiple barrel installations (e.g., one culvert barrel with baffles could serve as a low-flow barrel and fish passage structure, with one or more adjacent barrels designed for flood conveyance). However, this design approach must also then address the issue of “attraction flow,” so flow from barrels that have no baffles does not attract fish away from the passable conduit.

### Reference Documents

Bates, Ken, et.al. 2003. *Design of Road Culverts for Fish Passage*. Washington Department of Fish and Wildlife. Olympia, Washington. (In particular, see Chapter 5).

Maine DOT. 2004. *Fish Passage Policy and Design Guide*. Maine Department of Transportation. Augusta, Maine.

VDFW. 2005. *Interim Guidelines for Aquatic Organism Passage through Stream Crossing Structures in Vermont*. Vermont Department of Fish and Wildlife. Montpelier, Vermont.

## 4.2.10 Flow Conveyance Design

### Characteristics

Flow Conveyance Design is the conventional approach for designing hydraulically and structurally efficient bridges and culverts. MassDOT guidance documents describe the hydraulic and structural design criteria in detail. Flow Conveyance Design is based on the capacity to carry specified design flows, consistent with the provision of a structurally sound structure that supports the required roadway. This approach also provides for adequate scour protection, flow transition at the inlet and outlet, and energy dissipation at the outlet.

When bridges and culverts are designed solely for efficient flow conveyance, there are a number of features that can adversely affect aquatic and terrestrial wildlife passage. Conditions that can pose obstacles to wildlife movement include, but are not limited to, flow constriction at the inlet, hydraulic drop at flow transition into the structure, hydraulic jumps within the structure or downstream of its outlet, and shallow flows and comparatively high velocities within the structure. Upstream and downstream of these structures, alterations can occur in the natural channel as a result of the hydraulic conditions at the structure, resulting in obstacles to passage by organisms, as well as alterations to stream habitat.

### Conditions where applicable

All MassDOT structures designed for river and stream crossings should meet the minimum hydraulic and structural requirements of the MassDOT *Project Development and Design Guide* and the *Bridge Manual*.

However, structures designed solely for flow conveyance should be limited in application to the following conditions:

- New or reconstructed bridge or culvert designed primarily for storm water conveyance (for example, a culvert for a storm drainage ditch);
- Reconstruction/repair of structure located on a channelized stream or river where there is little realistic opportunity for restoration of natural ecologic condition and where fish passage is not required.
- Reconstruction/repair of a structure where a detailed analysis shows that other factors preclude the improvement of wildlife passage at the specific site. Such analyses might include, but not be limited to the following:
  - Potential displacement of or adverse effects on other structures, land uses, or utilities in the vicinity of the crossing;
  - Alteration of existing floodplain profile or extent of flooding either upstream or downstream of the structure;
  - Alteration of existing wetlands upstream or downstream, as a consequence of changes in the streambed profile or hydraulic gradient;

- Adverse effects on streambed stability (including potential head-cutting), stream bank stability, or sediment mobilization and transport characteristics either upstream or downstream of the structure;
- Alteration of scour potential and associated affects on bridge/culvert foundations.
- Potential environmental impacts during construction of the structure.

### **Information required for design**

All information typically required for design of MassDOT bridges and culverts, as set forth in the references listed below.

### **Reference Documents**

Massachusetts Executive Office of Transportation. *Project Development and Design Guide*. MassDOT. January 2006.

- Chapter 8 - Drainage and Erosion Control
- Chapter 10 – Bridges

Massachusetts Executive Office of Transportation. *2009 LRFD Bridge Design Manual*.

### 4.3 Supplemental Measures

With all of the bridge and culvert options discussed in this guidance document, the stream crossing installation may require supplemental measures to address hydraulic conditions, potential scour, streambed and bank stability, and other issues associated with the structure or the stream channel and banks. Such measures include design treatments to protect the integrity of the structure, prevent adverse impacts to the upstream or downstream banks and streambed, or restore disturbed streambed and bank. In conjunction with the selection and design of structures to meet roadway design criteria and stream continuity, the designer should consider the measures in Table 4-2.

**Table 4-2. Supplemental Measures at Stream Crossings**

Supplemental Measure	Function	Design Guidance
Wing walls and head walls	Flow transition at inlet and outlet of structure. Retention of embankment at structure to minimize flow length and encroachment into resource areas.	MassDOT <i>Bridge Manual</i>
Scour protection at structural elements	Prevention of undermining of bridge foundations.	MassDOT <i>Bridge Manual</i>
Energy dissipation at outlet	Prevention of scour at outlet, and control of down-cutting of downstream channel.  Note that pre-formed scour holes and armored linings may not meet River and Stream Crossing Standards. Alternative crossing designs may need to be considered to address potential scour at the outlet of the crossing structure.	MassDOT <i>Project Development and Design Guide</i>  MassDOT <i>Bridge Manual</i>
Channel grade control measures upstream and downstream of structure	Integration of replacement structure invert with adjacent channel. Enhancement of hydraulic profile to facilitate aquatic species passage.  These measures involve the placement of structural elements within the streambed to control head-cutting upstream of the crossing, to control tailwater elevations at the outlet, or to provide step/pool transitions in the channel to maintain conditions negotiable by aquatic wildlife.	Bates (2003), Chapter 7  Forest Service Stream-Simulation Working Group (2008), Appendix F  MDEWMA (2000), Sections 3.7 to 3.9.
Stream bank stabilization and restoration	Repair of stream banks damaged by previous conditions; Repair of banks affected by temporary construction activities	(Numerous reference materials are available; this topic is beyond the scope of this guidance document)
Stream restoration	Replacement of geologic, hydraulic and ecological functions resulting from past alterations of the stream channel.	(Numerous reference materials are available; this topic is beyond the scope of this guidance document)
Anti-floatation measures	Under certain conditions, the inlet ends of large corrugated metal culverts are subject to uplift by hydraulic forces, and need to be protected against such conditions.	MassDOT <i>Bridge Manual</i>



## 5.0 Constraints on Providing Passable Stream Crossings

### 5.1 General Discussion of Design Constraints

The designer needs to address multiple design standards and regulatory criteria when designing a roadway stream crossing. The designer also needs to consider these criteria within the various constraints on the roadway and crossing structure design. This chapter of the guidance document identifies key constraints that may affect the selection and implementation of a design strategy for a stream crossing that accommodates wildlife. Such constraints may limit the design choices to measures that cannot fully meet the River and Stream Crossing Standards. Where this is the case, it is important to identify and characterize such conditions early in the design development process, so that steps can be taken to address stream continuity to the maximum extent practicable.

In the development of new roadways, and the maintenance and redevelopment of existing roadways, numerous criteria apply to the design of proposed improvements. Lane widths, shoulder widths, intersection configurations, profile grades, pavement structures, bridge structures, and other roadway features are governed by state and national design standards that relate to traffic safety, structural integrity, context sensitivity, and other criteria. In addition, various regulatory criteria may apply, including requirements governing impacts on natural resources. Within this context, the Massachusetts River and Stream Crossing Standards present guidance for additional assessments and criteria for the designer to consider when MassDOT proposes reconstruction of an existing roadway or the provision of a new roadway or other transportation facility that will involve one or more stream crossings. Planning and design for project development must account for and reconcile multiple design standards and regulatory criteria, and resolve potential conflicts among these criteria.

The Massachusetts River and Stream Crossing Standards provide guidance applicable to new stream crossings and also to replacement crossings. The standards are intended to provide for stream crossings that permit the passage of a wide range of aquatic and terrestrial wildlife, at various life stages. The ultimate goal of the standards is to make transportation crossings of streams and rivers “transparent” to wildlife. However, there are many circumstances, particularly at existing crossings, where the provision of this full range of wildlife passage will be particularly challenging. There will be instances where site constraints, available resources, or pre-existing ecological conditions do not permit the implementation of a crossing in full compliance with the Standards. In these cases, alternative techniques should be considered to achieve compliance with the Standards to the extent practicable. In addition, situations may arise where a crossing will not be replaced (for example, an historic bridge structure) but where improvements to existing crossings are needed to address specific passage requirements for particular species – thus requiring retrofits of existing crossings. To provide alternative approaches for these conditions, a full range of ecological solutions to stream crossings has been presented in earlier chapters of this document.

This chapter does not deal specifically with all the engineering constraints normally associated with traffic engineering, roadway design, and the engineering of structures. Rather, it focuses on those conditions that bear on the selection and design of stream crossing structures to meet Stream Crossing Standards.

## 5.2 Typical Considerations and Constraints at Stream Crossing Structures

Table 5-1 presents a summary of constraints that may affect a particular crossing. Some of these conditions apply to both new and replacement crossings. However, MassDOT anticipates that designing new stream crossings in compliance with the River and Stream Crossing Standards will be subject to such constraints to a lesser degree than replacement crossings. Table 5-1 indicates whether each identified constraint typically applies to new or replacement crossings or both.

The stream crossing designer should characterize the constraining factors for the particular crossing under consideration, and apply these factors in the selection of bridge or culvert type during the design development process. Chapter 6 includes further discussion of this process.



Table 5-1. Designing Bridges and Culverts to Meet the Massachusetts River and Stream Crossing Standards: Potential Design Constraints

CATEGORY	CONSTRAINT	
	TYPICALLY APPLIES TO: Existing crossings	New crossings
<b>Cultural/Social</b>		
<b>Infrastructure</b>		
<b>Structural</b>		
<b>Hydrologic/Hydraulic</b>		

- Site of crossing contains archaeological resources.
- Crossing is a historic structure.
- Adjacent historic structures may be affected by modifications to the crossing.
- Stream crossing must be navigable by recreational and/or commercial watercraft.
  
- Approaching road grades are constrained by existing land use.
- Available width of replacement structure is limited by minimum clearance to nearby buildings or other structures.
- Utilities are located above, below, or on the existing crossing structure.
- Utilities are located adjacent to the watercourse and may be affected by the crossing.
  
- Lengths of bridge spans are limited by structural engineering requirements, as specified in the Bridge Manual.
- Sizes of bridge components, manufactured arches, and culverts are limited to sizes that can be shipped overland to the construction site.
- "Aspect ratios" of manufactured arches are constrained by structural requirements, limiting available options within vertical alignment constraints.
- Feasibility of bridge construction may be affected by potential for scour.
  
- Natural channel dynamics could result in potential channel adjustment (both vertical and lateral).
- If existing structure provides flood flow attenuation, modification could affect downstream flood profile. This could require detailed flood study, preparation of LOMR under FEMA, and negotiations with downstream property owners.
- Modification of crossing may result in potential for headcutting of streambed upstream and/or sediment deposition downstream.
- Modification of structure or adjacent channel may alter channel velocities or turbulence patterns.
- Potential for scour at the structure may affect the choice of structure and foundation design.
- Potential for scour at the outlet of the structure may affect the choice of structure design.
- If downstream channel has undergone degradation, this may affect vertical alignment and choice of in-channel modifications, to achieve an effective passable crossing design.
- Existing urbanization of the upstream and downstream channel may make it difficult or impossible to develop a "natural" crossing design. (Bankfull width may be indeterminate.)
- On a coastal stream, an existing culvert may provide flood protection to inland areas, because its hydraulic capacity may prevent inundation by tidal floods.

Table 5-1. Designing Bridges and Culverts to Meet the Massachusetts River and Stream Crossing Standards: Potential Design Constraints

CATEGORY	CONSTRAINT	
	TYPICALLY APPLIES TO: Existing crossings	New crossings
<b>Biological/Ecological</b>		
<b>Economic</b>		
<b>Constructability</b>		
<b>Maintainability</b>		

- Roadway impounded wetlands may have formed as a result of the existing structure alignment and hydraulics.
- Protected resource areas at the toe of the existing embankment may constrain choice of structure and its horizontal and vertical alignment.
- Upstream and downstream conditions may have highly favorable habitat conditions, and the new or replacement structure may be critical to habitat linkage (design of the local crossing must be considered in context of the stream system).
- Upstream and downstream conditions may severely impede development of stream continuity (design of the local crossing must be considered in context of the stream system).
- The construction process itself can have an adverse impact, depending on type of structure.
- In some unique situations, the existing structure may provide a desirable obstacle to the passage of undesirable species.
- Construction costs of some structural systems may be prohibitive, depending on scale of project.
- Costs to maintain some alternative crossing types may not be sustainable by the party responsible for long-term maintenance.
- Additional right-of-way or easements may be required if work extends outside the right-of-way (e.g., upstream or downstream channel restoration required to accommodate crossing design).
- Choice of structure type may be affected by accessibility of work site.
- Choice of structure type may be affected by a need to maintain traffic during construction.
- Choice of structure type may be affected by feasibility of conducting construction operations within the limits of the stream or by other construction phase water handling requirements.
- Choice of structure type may be affected by permit time restrictions ("work in water" seasonal time limits).
- Choice of structure type may be affected by feasibility of performing construction required construction operations (e.g., placement of materials within a culvert or beneath a bridge span) or other factors.
- Choice of structure type may be affected by accessibility for required maintenance.
- Choice of structure type may be affected by other maintenance considerations.

### 5.3 Constraints Affecting Replacement of Existing Crossing Structures

Replacement of existing stream crossings to address the River and Stream Crossing Standards is likely to prove particularly challenging to the designer. There are several common issues at existing crossings that can limit the choice of alternatives for replacement structures.

#### Vertical Clearance Constraints

On reconstruction projects, the design cannot always alter a road's centerline profile to meet the Stream Crossing Standards. In many cases, the profile is fixed by surrounding land uses, nearby roadway and driveway intersections, or vertical clearances to other structures such as nearby bridges. Figure 5-1 shows how replacement of an existing culvert that currently does not meet the Standards might require a larger opening and greater clearance above the invert of the stream channel. If the roadway profile cannot be raised, the choice of structures for a replacement bridge or culvert can be limited. For a bridge, the depth of the beams supporting the bridge will depend on the type of material and span. For a "bottomless culvert", the dimension of its span relative to its rise (aspect ratio) is limited by structural considerations, and the walls and top of the culvert must meet minimum thickness requirements. As a result of these limitations, the available vertical clearances at a replacement crossing may limit the ability to meet both the span and openness requirements called for by the Standards.

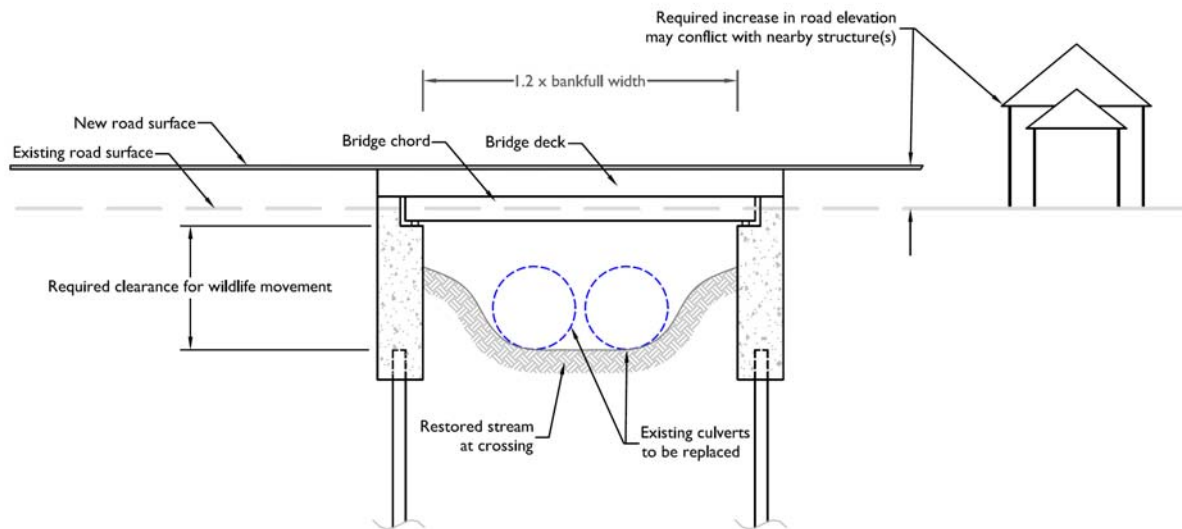

**Figure 5-1. Example of Vertical Clearance Limitations for a Replacement Structure**

A related clearance issue can occur when reconstructing an existing bridge to meet new structural design criteria. The updated design may require a larger beam to meet new structural standards. If the design must maintain the existing road profile, then a reduction of the vertical clearance beneath the bridge would result.

In some cases, the opportunity to raise an existing roadway profile can also be limited by the proximity of wetland resource areas (see discussion under “Potential Wetland Impacts” below).

The requirement to maintain navigability for recreational or commercial watercraft can also affect choice of bridge or culvert structure, in order to provide sufficient clearance for navigation.

### Potential Wetland Impacts

Increasing the width or vertical clearance of an existing culvert or bridge span to improve wildlife passage can have unintended adverse affects on adjacent wetlands.

If a replacement culvert or bridge requires raising the existing roadway profile and the roadway is adjacent to a wetland, the increase in embankment height might result in encroachment by the toe of embankment into the wetland (Figure 5-2). Alternatively, such an increase in embankment height might require construction of a retaining wall to minimize encroachment into a wetland, and the retaining wall itself could be a barrier to wildlife passage.<sup>30</sup> Thus, the proximity of wetlands to a stream crossing structure can limit the adjustment of vertical road profile, in turn limiting the choice of bridge or culvert type at a particular crossing.

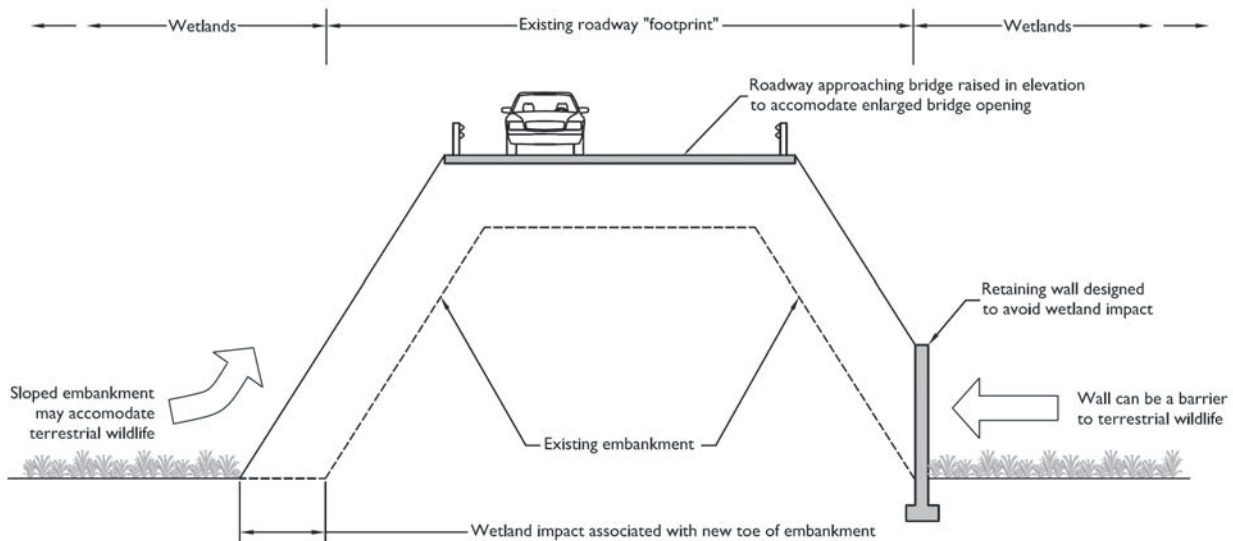

**Figure 5-2. Example of Wetland Impacts of Raising Approach Road to Reconstructed Stream Crossing**

<sup>30</sup> Note, however, that these barriers to wildlife movement across roadway surfaces can sometimes be designed to coerce or guide terrestrial and semi-aquatic species through a culvert or bridge stream crossing.

Another concern relative to wetland impacts is that older culverts may have altered stream hydrology over the course of time, resulting in the establishment of wetland habitat that could be impacted by culvert replacement. An existing roadway culvert installed twenty or thirty years ago is likely to be considerably smaller in flow area than a replacement structure meeting the Standards. Subsequent to installation of the culvert, land use changes are likely to have occurred, and may have altered the watershed hydrology. Under such circumstances, a culvert can become an “outlet control structure”, impounding flood flows upstream. This can result in deposition of sediment upstream, changes in hydrology upstream, and the development of wetland resource areas that did not previously exist.

Replacing such a culvert to provide for stream continuity could restore original hydrologic conditions, but could also result in an alteration of the wetland that has developed in consequence of the constriction caused by the existing structure (Figure 5-3). Such alteration could require review and authorization under the Massachusetts Wetlands Protection Act, Section 404 of the federal Clean Waters Act, and other applicable regulations. The analysis and design of a replacement crossing must address the potential for altering adjacent wetland resources.

However, this potential for wetland alteration should not necessarily deter designers from proposing improvements in stream continuity. The Massachusetts DEP, in its policy guidance on dam removal, has noted that the loss of upstream wetlands may be offset by the overall benefits of the river restoration.<sup>31</sup> As with dam removal, the long-term benefits of improved stream continuity – including aquatic organism passage and the transport of sediment, debris, and nutrients – generally outweigh short-term environmental impacts, including an incidental wetland loss. Early coordination is warranted with affected resource agencies to characterize the benefits and impacts of a proposed replacement structure designed for fish and wildlife accommodation, and to determine how to address wetland alterations associated with this improvement.

In some cases, the choice of crossing structure type, its dimensions, and the elevation of its invert will be limited by the need to avoid impacts to these regulated resource areas. In other cases, such impacts can be avoided or corrected by installation of corrective measures, such as grade controls to avoid upstream head-cutting as shown in Figure 5-4.

In-stream measures to prevent or correct the upstream head-cutting described in Figure 5-4 might include the installation of boulder weirs, as shown in this sketch, or other grade control measures. Use of “natural stream design” techniques incorporating native materials for the grade controls is preferable to installation of engineered structures.

---

<sup>31</sup> MassDEP (2007), p.9.

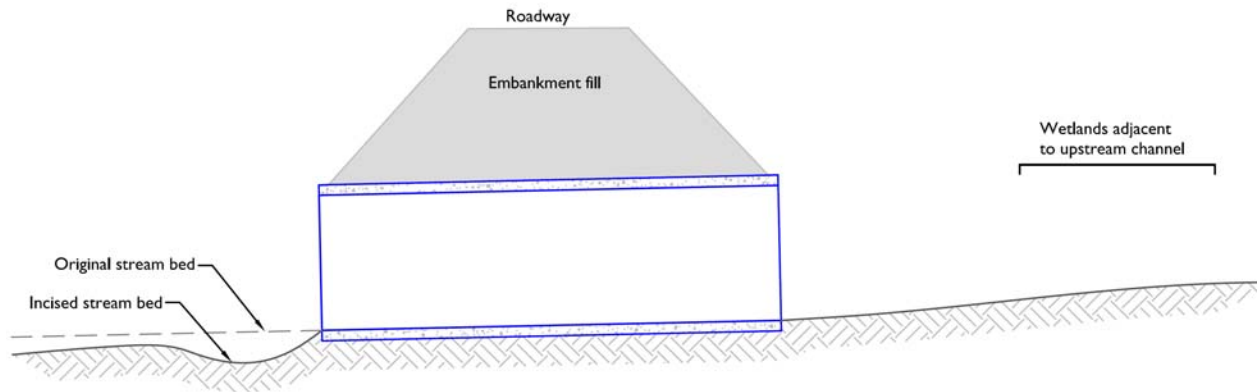

(a) Conditions associated with existing culvert.

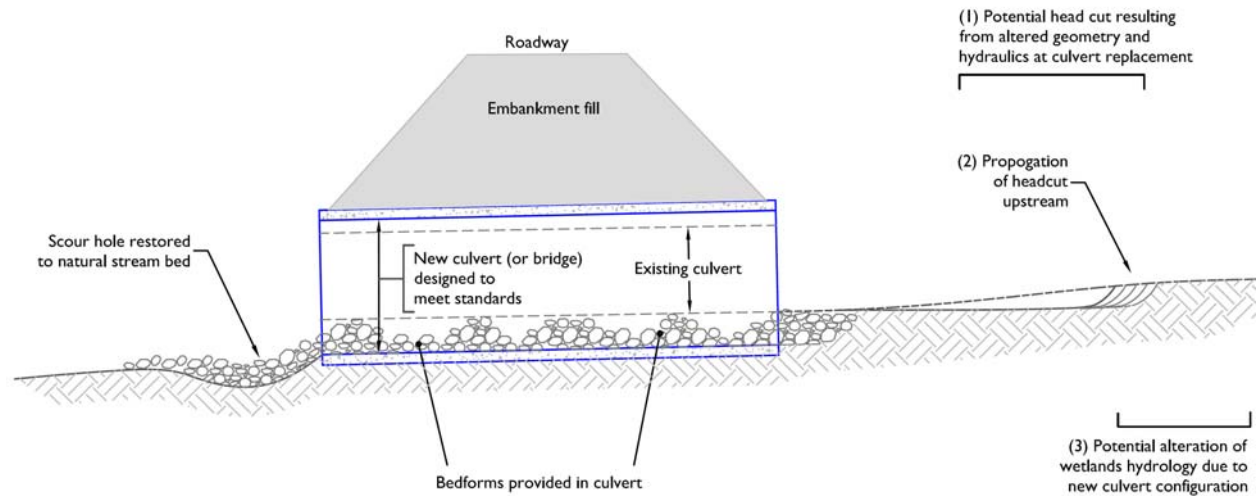

(b) Conditions associated with replacement structure.

**Figure 5-3. Potential Alteration of Upstream Wetlands as a Result of Culvert Replacement.**

This figure illustrates the condition where wetlands have developed upstream over the time period that an existing culvert has been in place. Replacement of the culvert with a structure having a larger opening may result in an upstream channel adjustment, or a “head cut” (progressive erosion of the upstream channel), that lowers water levels and alters the condition of the upstream wetland system.

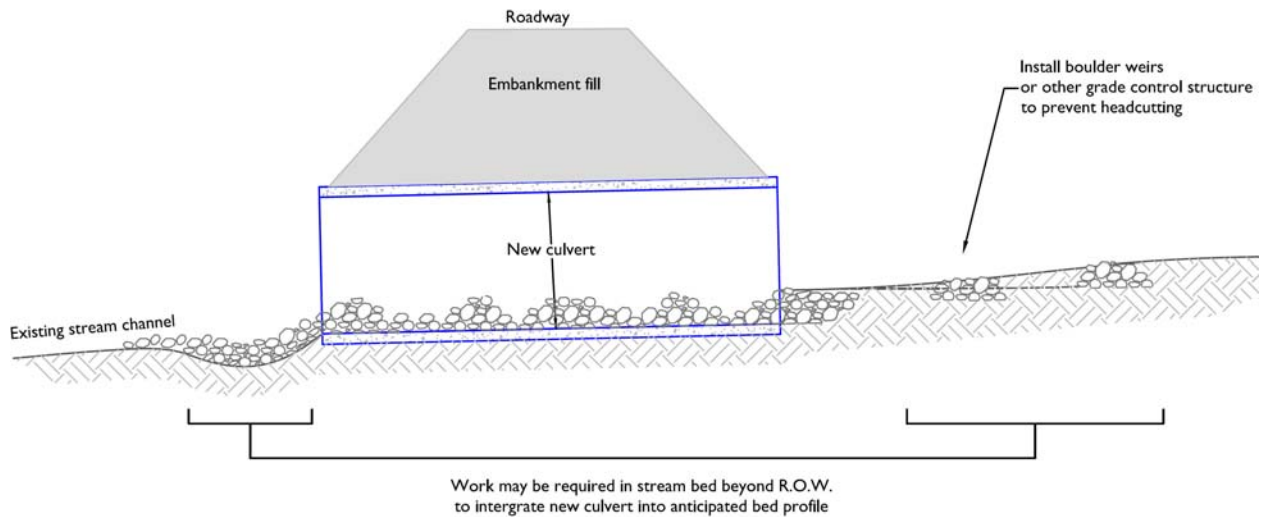

**Figure 5-4. Example of Measure to Prevent Headcutting.**

### Existing Flood Elevations

The replacement of an existing crossing with a wider structure to accommodate wildlife may result in an alteration of hydraulic characteristics at the crossing. This may have an adverse affect on the base (100-year) flood profile at the existing crossing, and may thus constrain the implementation of habitat accommodation.

Existing bridges or culverts with widths significantly narrower than upstream channels and their floodplains may cause impoundment of flows during flood conditions. Removing such a bridge or culvert and replacing it with one designed for wildlife passage may result in a structure that has greater conveyance capacity. This can reduce the flood storage induced by the old structure. While this action might lower flooding elevations upstream, it also can result in higher downstream flood elevations (Figure 5-5). The design of the replacement crossing would need to account for this potential increase in downstream flood profile.

If the affected reach of the stream was studied in detail during the community's National Flood Insurance Program (NFIP) Flood Insurance Study (FIS) and had regulatory floodway delineated within its base floodplain, then the project must not result in any increase to the stream's base flood elevation profile or necessitate widening the existing regulatory floodway delineation. If the project cannot conform to these performance standards, then MassDOT must file a Conditional Letter of Map Revision (CLOMR) with the FEMA Region One Office. Such an action may potentially affect the feasibility of implementing wildlife accommodation measures as part of the replacement project.

Designers should refer specifically to provisions of 44 CFR Section 60.3 (FEMA Regulations) for additional information regarding compliance with the performance standards of the NFIP. Designers should also refer to the 2009 MassDOT *LRFD Bridge Design Manual* for specific requirements applicable to the hydraulic design of crossing structures.

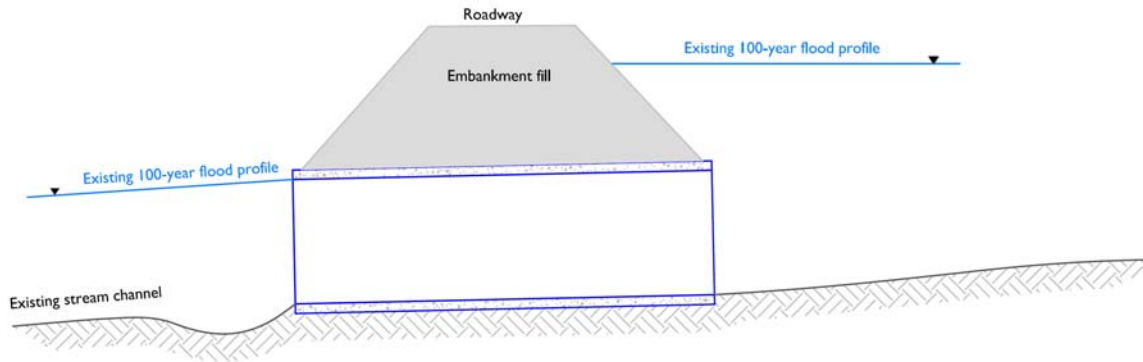

(a) Predicted flood elevations with existing culvert.

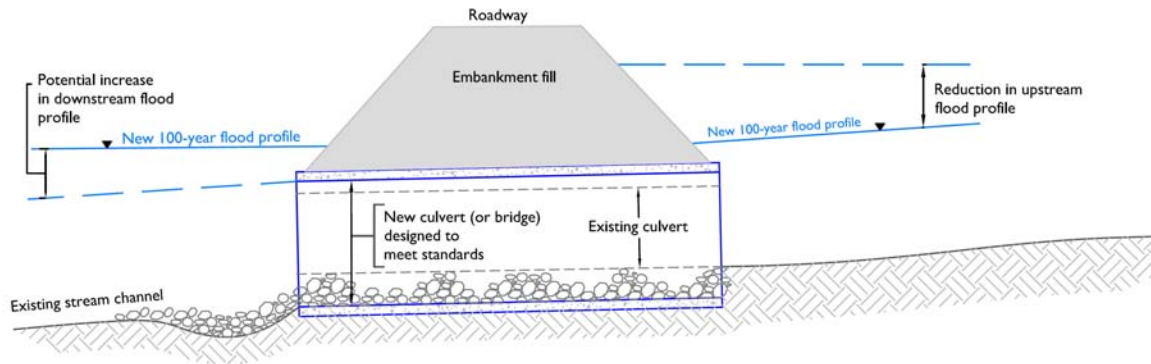

(b) Predicted flood elevations with replacement structure.

**Figure 5-5. Potential Alteration of Flood Elevations as a Result Culvert Replacement.**

An increase in the downstream flood profile may result in adverse impacts to downstream properties. If FEMA has conducted a study of the affected downstream reach, replacement with the new culvert may require filing a Conditional Letter of Map Revision (CLOMR) with FEMA.



## Existing structures and utility infrastructure

Another common condition at an existing stream crossing is the presence of building foundations or utility infrastructure in close proximity to the crossing (Figure 5-6). The reconstruction of the crossing structure may then be constrained by the ability to relocate such infrastructure. Often, the reconstruction will need to accommodate such infrastructure in its current place. Note that utilities may cross the stream at the location of the existing bridge or culvert, or they may parallel the stream. Utility crossings of the streambed are common in urbanized areas, and care must be taken in the reconstruction of stream crossings and the restoration streambeds to avoid exposing these utilities, either as a direct result of construction, or as a result of channel adjustment that may occur after the replacement has been completed. In some cases, a box culvert may be a logical choice for a replacement structure (even though a bridge might be preferred for stream continuity), because the bottom chord of the box serves as an effective grade control structure that would protect utilities located beneath the structure or in the nearby streambed.

## Construction Requirements

Construction considerations can influence the selection and design of new or replacement structure. The practicality of installing a particular structure, space limitations on the access and use of equipment, and measures to protect the environment during construction can all have a bearing on the choice of type of structure.

For example, when an existing stream crossing is removed and replaced, flows in the existing river or stream must be maintained during the period of construction, with a minimum of impact on habitat. In situations where there is limited work space because of site constraints, this requirement can often be easily addressed by the use of a double box culvert to replace an existing bridge or substandard culvert. Flow can be maintained in the existing channel while one barrel of the replacement culvert is installed. Then flow can be diverted into this new culvert barrel, while the second barrel is installed. This process can result in the time-efficient placement of a new structure, with positive benefits to the ecology of the stream.

However, it results in a vertical wall within the overall channel width. This vertical wall might interfere with natural sediment transport and conveyance of debris, and the resultant crossing may not fully comply with the River and Stream Crossing Standards. However, in some instances, the structural advantages of the multiple box culvert and the construction efficiencies of this type of crossing may favor this design solution for a site constrained by the existing built environment and other design requirements.

The “constructability” of a crossing structure can also be an issue. For example, the placement of streambed within a confined space to produce a “stream simulation culvert” can be problematic, if the size of rock substrate material and available clearance within the structure cannot be addressed with routinely available equipment.

Another aspect of construction that may need to be considered in the choice of structure is whether traffic must be maintained at a crossing throughout the duration of the construction project.

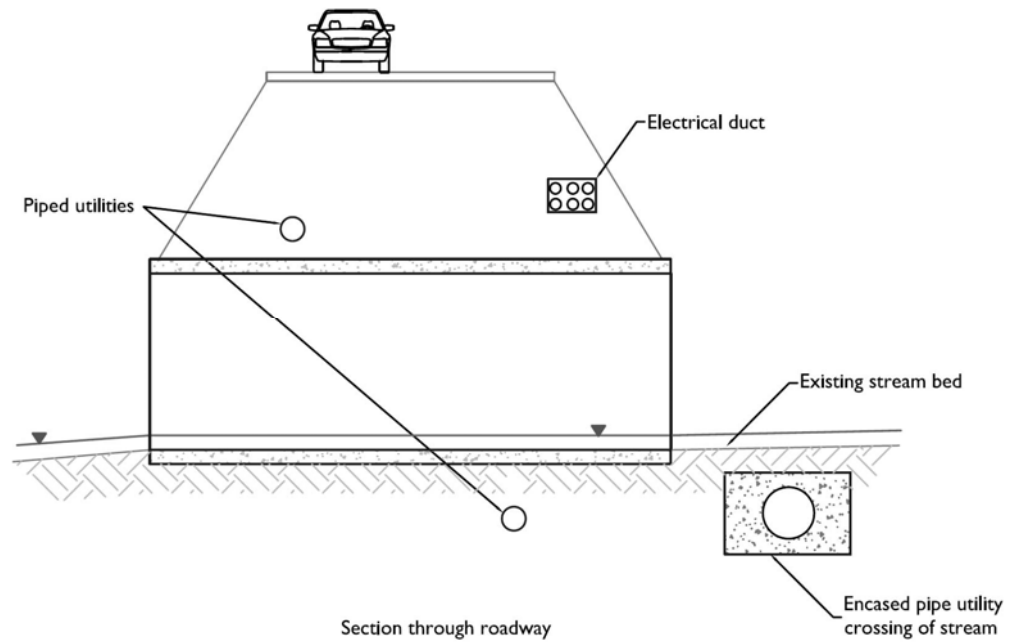

(a) Utilities at or near culvert.

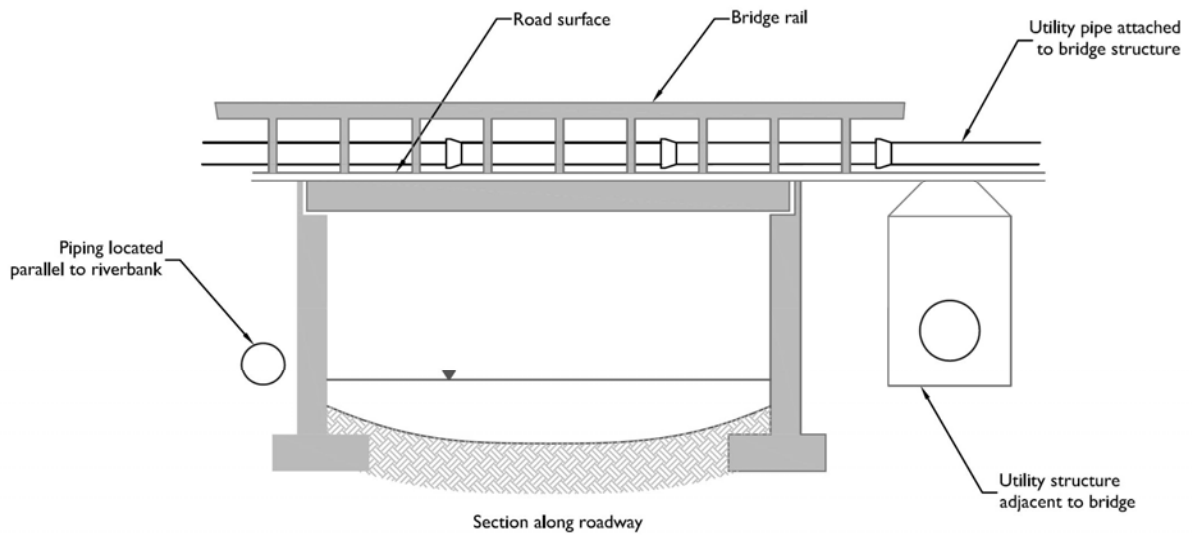

(b) Utilities on or near bridge structure.

**Figure 5-6. Utilities at Existing Crossings Can Limit Options for Replacement Structures.**

## Maintenance Considerations

Selection and design of a bridge or culvert should consider long-term maintenance requirements, which may affect the choice of structure type. If the interior of a structure will require inspection and maintenance, then the interior of the crossing must be accessible for the necessary maintenance activities. If existing conditions preclude such access, then an alternative type of structure may be required.

Preference should be given to structures with minimum maintenance requirements. Structures that are prone to clogging by debris should be avoided, where feasible. Embedment designs must consider the long-term sustainability of bed materials.

Bridges or culverts with baffles or other integral fish passage features will require an ongoing maintenance program to keep these features in operable condition, including periodic removal of debris and repair of damaged components.

Structures that provide for a full-span of the bankfull channel and properly designed bed materials within the structures are actually anticipated to require less waterway-related maintenance than some more conventional designs that constrict flows, trap debris, and promote channel scour.

## Available Right-of-Way

Some bridge/culvert design options for habitat continuity require work in the stream up-gradient and down-gradient of the stream crossing. This restoration or enhancement activity not only must be implemented within regulatory requirements for work in natural resource areas, but may also require work outside the limits of MassDOT right-of-way. In such cases, easements from affected property owners would be needed to perform the required work. The ability to obtain these easements in a timely and cost-effective manner may affect the choice of design for the crossing.

The above discussion presents some examples of conditions commonly encountered at stream crossings, particularly replacement structures. The possible scenarios of design constraints, and associated universe of potential solutions to address stream continuity, would be too numerous to cover in this document. However, it is important that the designer identify the applicable constraints early in the design development process. The characterization of the key conditions affecting the placement or the replacement of a stream crossing can then inform the decision-making process for selecting an appropriate structure and proceeding with its design. Chapter 6 discusses this decision making process.



## 6.0 Project Development and Design for Stream Crossings

MassDOT design guidance and practices include provisions to ensure that the project initiation, planning, development, and design process considers habitat continuity at stream crossings, provides for coordination with affected environmental agencies, and incorporates crossing design measures to achieve compliance with applicable regulations. This chapter describes how MassDOT’s project development and design process integrates provisions for complying with the Massachusetts River and Stream Crossing Standards.

MassDOT projects advance from the identification of need to the construction of new and reconstructed roads and bridges in accordance with the Massachusetts Highway Development and Design Guide (2006). In addition, MassDOT’s Bridge Design Manual also governs the design of bridges as well as many culverts. The design of stream crossing structures must proceed in accordance with these fundamental MassDOT guidance documents and related MassDOT practices.

### 6.1 MassDOT Project Development and Design Guide

MassDOT’s Project Development and Design Guide sets forth specific requirements focused on the design of projects to address environmental context and to comply with regulatory programs. Pertinent sections of that guidance that specifically apply to the design of new and replacement stream crossings include (but are not necessarily limited to) the provisions identified in Table 6-1.

The design of stream crossings to address wildlife passage parameters and constraints is consistent with and required by the Design Guide.

### 6.2 MassDOT Bridge Manual

The MassDOT Bridge Manual includes provisions that require the consideration of environmental context and pertinent design requirements in the development of bridge designs. In particular, Part 1, Chapter 2, Section 2.3.6 specifies the contents of the Bridge Type Selection Worksheet. Bridge designers and reviewers should note the following requirements:

Section 3.9 of the worksheet must identify

*“Constraints Imposed by Environmentally Sensitive Areas: (Identify all restrictions imposed by regulations for environmentally sensitive areas that may be affected by the construction of the bridge structure and its foundations or by any approach roadway work.)”*

Section 4.0 of the Bridge Type Selection Worksheet must include a discussion of how each viable bridge type alternative can meet these constraints (as well as other project objectives and constraints).

This guidance recommends that the bridge type selection process should address wildlife accommodation at stream crossings, by considering streams and rivers “environmentally sensitive areas” and addressing

aquatic and other wildlife passage issues early in the evaluation of alternative structures for both new and replacement crossings.

**Table 6-1. Project Development and Design Guide Provisions for Habitat Continuity at Stream Crossings**

Section	Requirement
<b>Chapter 2. Project Development</b>	
2.4.2 Environmental Documentation and Permitting 2.4.2.1 Early Coordination	<ul style="list-style-type: none"> <li>Requires early coordination with local environmental boards and commissions (early in the preliminary engineering phase)</li> <li>“For projects affecting rivers and streams, the proponent should consult with the Massachusetts Department of Fish and Game (Riverways Program), Division of Marine Fisheries (marine resources, especially diadromous fish), Natural Heritage and Endangered Species Program (Biomap and Living Waters Analyses), and the National Park Service (Wild and Scenic Rivers System).”</li> </ul>
2.4.3.1 Preliminary Design Process (25%)	<ul style="list-style-type: none"> <li>Under “Develop Bridge Type Studies and Sketch Plans for Bridges, Culverts, and Walls,” requires the project proponent to be familiar with the guidelines for Wildlife Accommodation outlined in Chapter 14.</li> </ul>
<b>Chapter 8. Drainage and Erosion Control<sup>32</sup></b>	
8.2. Procedures 8.2.2 Coordination with Other Agencies 8.2.3 Documentation Necessary for Drainage Designs	<ul style="list-style-type: none"> <li>Requires developing an understanding of the environmental context and constraints of the project.</li> <li>Requires coordination with other agencies regarding applicable regulatory requirements, and coordination with MassDOT Environmental Section regarding threatened and endangered species and other regulatory issues.</li> </ul>
8.4.2 Culverts 8.4.2.3 Basic Design Criteria	<ul style="list-style-type: none"> <li>Includes Wildlife Accommodation as a basic design criterion</li> <li>References US Army Corps of Engineers Programmatic General Permit Conditions.</li> <li>References Chapter 14 of the Project Development and Design Guide.</li> </ul>
<b>Chapter 10. Bridges</b>	
10.2.4 Crossings of Streams, Rivers, and Other Natural Features	<ul style="list-style-type: none"> <li>Designer should reference the Massachusetts River and Stream Crossing Standards and Chapter 14 of the Design and Development Guide.</li> <li>“Both new and replacement bridges and culverts can also be used to improve the connectivity of habitat in certain locations, whether or not they are placed for a hydraulic function. Design of both bridges and culverts should consider effects on wildlife habitat, fish passage, and other considerations in Chapter 14.”</li> </ul>
10.3.1 Understanding the Context 10.3.1. Environmental Resources	<ul style="list-style-type: none"> <li>Requires general consideration of environmental impacts on sensitive resources such as wetlands, streams, and rivers.</li> </ul>
<b>Chapter 14. Wildlife Accommodation</b>	
Exhibit 14-1	<ul style="list-style-type: none"> <li>Requires considering wildlife accommodation if roadway crosses areas of statewide or regional importance for landscape connectivity</li> <li>Requires considering wildlife accommodation if roadway crosses fish-bearing stream and if new or existing culverts are potential fish passage barriers.</li> </ul>
14.3. Wildlife Accommodation Guidelines	<ul style="list-style-type: none"> <li>References Massachusetts River and Stream Crossing Standards</li> <li>References US Army Corps of Engineers Programmatic General Permit Conditions.</li> </ul>

<sup>32</sup> Chapter 8 covers the design of culverts. A culvert is not classified as a “bridge” if it has a span of less than 20 feet. However, note that Section 8.2 states that the MassHighway Bridge Division is responsible for the structural design of all bridges and **box culverts** with spans over 8 feet.

### 6.3 Design Development Requirements and Stream Continuity

The design of stream crossings to accommodate wildlife requires that the criteria for such passage be integral to the entire design process. The design cannot successfully implement stream continuity by introducing accommodation considerations near the end of the design process as an “add-on” feature. If a project will be required to meet the width, opening, and embedment requirements of the River and Stream Crossing Standards, the original analysis of the crossing and the structure selection process should address these criteria.

Therefore, this guidance recommends the following:

1. The project planning and initiation process, as well as the early phases of design, will need to consider criteria of the General Standards and, in some cases, the Optimum Standards of the MA River and Stream Crossing Standards as they apply to particular stream crossings. Whenever the *MassDOT Bridge Manual* requires a “Bridge Type Study”, the criteria for structure selection should include the consideration of accommodation in accordance with this guidance document. If a structure cannot be designed for accommodation following the guidelines in Chapter 3 of this document, the rationale for such a conclusion should be documented in the Type Study, and alternatives should be evaluated to achieve stream continuity requirements to the maximum extent practicable. Where structures are likely to consist of culverts not subject to the *MassDOT Bridge Manual*, the early planning and design process also needs to include tasks specifically addressing wildlife accommodation. Designers should consult with MassDOT’s Environmental Section during the Type Study phase for guidance on the evaluation of alternative structures.
2. On any particular project, the bridge/culvert design team and MassDOT project staff should coordinate early in the project planning and initiation processes with the affected regulatory agencies listed in Table 6-1, and others as applicable, to
  - a. confirm the pertinent standards,
  - b. engage in an informed discussion of the constraints that may limit the degree of wildlife passage achievable at the crossing under study.

This coordination effort should occur before completion of the Bridge Type Study, so that regulatory input would inform the structure selection process. Valid cost analyses should also be conducted, for budget level estimates of project design and construction costs, including the incremental costs allocable to wildlife accommodation requirements.

3. Chapter 1 of the *Bridge Manual* specifies information required for the design of bridge structures. The information listed is detailed and exhaustive for the hydraulic and structural design needs of a bridge or major culvert. The information is likely also sufficient to address the River and Stream Crossing Standards, if the proposed structure is a new clear span bridge with no work proposed in the streambed, including a “Bridge Replacement with Retained Abutments” as described in Chapter 4 of this document.

However, if aquatic or aquatic/terrestrial wildlife passage will be addressed by an alternative design, or if the anticipated structure will require work in the existing stream channel (including

but not limited to streambed simulation, replication, or restoration), then the required information should be augmented to include data needed to inform the selection and design process for stream continuity. Required information is as follows:

- a. The stream survey should include a detailed profile of the thalweg (deepest part of the stream channel, sometimes referred to as “thread of stream”) for a sufficient distance upstream and downstream of the proposed crossing to enable evaluation of the potential for vertical channel adjustment of the stream. Rock outcrops and other natural or man-made structural features that could affect channel adjustment should be noted in the survey. Specific guidance in the literature for the length of such profile survey is limited, but until further documentation suggests otherwise, this guidance document recommends the following minimum distance should be surveyed both upstream and downstream of the crossing:
  - i. At least 20 times bankfull width (but no less than the distances listed below);
  - ii. No less than 200 feet for structures not covered by the Bridge Manual;
  - iii. No less than 500 feet as currently stipulated for structures subject to the Bridge Manual.
- b. Hydrologic evaluation should include the characterization of low flows, an estimate of the “bankfull discharge” (see discussion of bankfull parameters in Chapter 2 of this document), and - where specific fish species must be accommodated – estimated migration period flow conditions, for use in the design of the crossing for aquatic species passage. If specific species must be addressed by a crossing design, then the hydraulic and other design data pertinent to those species should be verified with the regulatory community early in the design development process. Design peak flows (or flood flows) ordinarily included in hydraulic analysis of bridges and culverts should suffice for evaluation of capacity and stability of stream crossings designed for habitat continuity.
- c. Qualified professionals should conduct a field analysis of the stream to establish the bankfull width parameter required for design, and to describe the stream morphology in detail. Personnel knowledgeable in fluvial geomorphology, and familiar within this field of study in the geological setting of Massachusetts, should perform this characterization.

The study team should document its findings in a report. The report should identify the indicators and procedures used to estimate bankfull geometry, include applicable calculations, provide other geomorphic information as discussed below, and include supporting photographs. In addition to bankfull geometry, the description of morphology typically includes plan form, bed forms, and substrate conditions based on field observations and map analysis, grain-size analyses of substrate materials (including coarse size materials – boulders and cobbles – as well as fines), and assessment of hydrologic data for the watershed of the stream.



This information is required to design the crossing's horizontal and vertical alignment, and to provide data needed for stream-simulation substrate design. It is helpful to conduct this task prior to completing the hydrographic survey (for example, in conjunction with the delineation of wetland resource areas), so that the surveyor can be directed to obtain detailed topographic information on these important geomorphic features.

- d. The "Stream Simulation" design involves construction of a sustainable stream bed within the crossing structure. This requires information to determine the appropriate features for the stream bed (e.g., channel shape and alignment, bed materials, pool/riffle characteristics). Design development of a crossing structure incorporating "Stream Simulation" may require additional survey of a "reference stream", if the local stream does not serve as a suitable model for streambed replication in the crossing structure. For example, if the crossing is significantly steeper than the nearby streambed, or if historical development has altered the nearby streambed so as not to represent natural conditions, then another stream may need to be evaluated as a model for the design. In that case, field survey and analysis of the reference stream should be conducted as discussed above in paragraph (c).

The integration of stream habitat continuity into the early phases of crossing structure analysis and conceptual design development is essential to the successful implementation of stream crossings that functionally accommodate wildlife movement.

## 6.4 Priorities of the Design Technique Options

This guidance document assumes that MassDOT stream crossing designs for both new structures and replacements will consider wildlife accommodation wherever feasible. This document is also premised on the understanding that design constraints are an inherent feature of the engineering process, and that there will be conditions – especially in the case of replacement crossings – where such accommodation cannot be fully implemented. So that the design process ensures compliance with applicable regulations and standards governing wildlife accommodation at stream crossings, this document includes design criteria in Chapter 3 to serve as a guide for prioritizing the selection of design approach for each new or replacement crossing.

For purposes of selection and design, the Flow Conveyance Design should be considered the minimum design criteria for any culvert or bridge – that is, all culverts and bridges must meet the minimum hydraulic and structural criteria previously applied by MassDOT and codified in the *Project Design and Development Guide* and in the *Bridge Manual*. However, to achieve wildlife accommodation to the maximum extent practicable (including, where applicable, compliance with the River and Stream Crossing Standards), the design of each new or replacement crossing should generally strive for the most advanced “ecological solution” presented in Table 3-1 of Chapter 3, within the applicable constraints.. The range of “ecological solutions” is further discussed Chapter 4, and summarized in Figure 4-1 and Figure 4-2.

If there are compelling constraints that preclude designing a new or replacement structure to accommodate wildlife passage as stipulated in Chapter 3, then the design team should initiate early coordination with natural resource agencies through MassDOT’s Environmental Section, to determine an acceptable approach to the crossing design.

Note that the valley span option is likely to exceed the Massachusetts River and Stream Crossing Standards, and has not been cited in those standards. The option is listed in this document in order to present the full range of opportunities for accommodating wildlife passage. In many cases, economic considerations may prohibit consideration of this type of span. However, it should be considered among the “tools” available to address habitat continuity, and may be particularly useful in some unique habitat settings. This type of structure may also be a cost-effective alternative for some “light-duty” applications such as pedestrian and bicycle trails, where the cost of the valley span may be favorable when compared to the cost of fill to carry the pathway across the valley floodplain.

The user of this handbook should also note that, as described in Chapter 3, some rivers and streams might be so wide that their bankfull widths will exceed the limits of maximum span for various bridge types, as set forth in the *Bridge Manual*. In those cases, intermediate bridge supports would be required within the channel. This design condition is beyond the scope of this document, and requires early consultation with the affected regulatory agencies in order to address the potential impacts on the stream system. This type of design is likely to require an individual Section 404 permit and other regulatory review, in any event. However, other aspects of the design for such a structure should be able to meet the underlying objectives outlined in Chapter 3 and the applicable referenced standards.

The design of all new and replacement crossings should evaluate the capacity to convey design flood flows, to meet the minimum flow conveyance standard. However, where natural streambed materials are incorporated into the design, the analysis must also include an evaluation of the stability of that bed

material under those flow conditions. This analysis can and should allow for the mobility of sediments, consistent with natural sediment transport function. However, bed material should not be less stable than that found in the adjacent stream system. Where necessary to address the dynamic stability of the bed material, the design substrate gradation should be modified and/or floodplain conveyance measures should be provided to reduce the stress on the primary crossing.

Where a structure cannot be designed to fully meet the Massachusetts River and Stream Crossing Standards, this document recommends that the design should strive to address the functional features of the crossing that make a culvert or bridge opening an obstacle to wildlife passage. These fundamental considerations include the following:

- Foremost, crossings should be designed to achieve velocities comparable to those in the adjacent stream system during low and ordinary flows. Velocities should also be within target species ability/endurance ranges during migration period flows, if anadromous or catadromous fish are present;
- Crossings should be designed to remove or mitigate physical drops, and to minimize hydraulic conditions that cause channel adjustments that result in such drops. In line with this objective, crossing structures should be designed so that hydraulic drops, jumps, or turbulent transitions do not occur within the bridge/culvert or at its inlet or outlet;
- Crossings should be designed to maintain water depths similar to the adjacent natural stream channel under low and ordinary flow conditions, and during migration periods if applicable to fish species in the stream. Where “target” fish species have been identified, structure design should incorporate depths documented in the literature for the species at the target life stage. Where the hydraulic characteristics of the crossing structure do not permit achieving these depths, then consideration should be given to development of passable modifications of the downstream channel, to maintain a tailwater elevation during low flows above the outlet invert of the crossing structure.
- When feasible, substrate continuity should be provided. Preferably, substrate should be of consistent material and texture to the adjacent stream system. If required for stability, larger substrate materials may be used, but should be in the same general range as the largest particles found in the existing stream system in the vicinity of the crossing. Breaks in such substrate continuity may be unavoidable in some instances to provide for stable conditions at the culvert/bridge outlet – for example, if an armored plunge pool is required.
- When feasible, the crossing structure should meet the openness values specified by the River and Stream Crossing Standards.

As noted earlier, the goal of this document is to identify measures that can comply to the maximum extent practicable with the River and Stream Crossing Standards. This suggested prioritization of functional requirements is offered in the understanding that “real world” applications sometimes require alternative measures to accomplish some improvement when competing design criteria and physical site constraints limit design options.



## References:

- Bates, Ken, et.al. 2003. *Design of Road Culverts for Fish Passage*. Washington Department of Fish and Wildlife. Olympia, Washington.
- Bent, G.C., 2006, Equations for Estimating Bankfull-Channel Geometry and Discharge for Streams in the Northeastern United States. In Proceedings of the Joint Federal Interagency Conference, Book of Abstracts, 3rd Federal Interagency Hydrologic Modeling Conference and 8th Federal Interagency Sedimentation Conference, Reno, Nevada, April 2-6, 2006, p. 314. Accessed at [http://ma.water.usgs.gov/projects/pdf/Poster\\_Bent\\_AbstractOnly.pdf](http://ma.water.usgs.gov/projects/pdf/Poster_Bent_AbstractOnly.pdf)
- Dunne, Thomas, et al. 1978. *Water in Environmental Planning*. W.H. Freeman and Company, New York, New York.
- Forest Service Stream-Simulation Working Group. 2008. *Stream Simulation: An Ecological Approach to Providing Passage for Aquatic Organisms at Road-Stream Crossings*. USDA Forest Service National Technology and Development Program. (0877 1801-SDTDC)  
<http://www.fs.fed.us/eng/pubs/pdf/StreamSimulation/index.shtml>
- Gubernick, Bob. et al. 2003. Design and Construction of Aquatic Organism Passage at Road-Stream Crossings: Site Assessment and Geomorphic Considerations in Stream Simulation Culvert Design. In 2003 Proceedings of the International Conference on Ecology and Transportation, edited by C. Leroy Irwin, Paul Garrett, and K.P. McDermott. Raleigh, NC: Center for Transportation and the Environment, North Carolina State University.
- Gubernick, Bob. et al. 2003. Design and Construction of Aquatic Organism Passage at Road-Stream Crossings: Designing Culverts for Aquatic Organism Passage: Stream Simulation Design. In 2003 Proceedings of the International Conference on Ecology and Transportation, edited by C. Leroy Irwin, Paul Garrett, and K.P. McDermott. Raleigh, NC: Center for Transportation and the Environment, North Carolina State University.
- Gubernick, Bob and Luna B. Leopold. 2003. Design and Construction of Aquatic Organism Passage at Road-Stream Crossings: Construction Challenges and Case Studies of Stream Simulation Structures for Aquatic Organism Passage. In 2003 Proceedings of the International Conference on Ecology and Transportation, edited by C. Leroy Irwin, Paul Garrett, and K.P. McDermott. Raleigh, NC: Center for Transportation and the Environment, North Carolina State University.
- Harrelson, Cheryl C., Rawlings C. L., and Potyondy, John P. 1994. *Stream Channel Reference Sites: An Illustrated Guide to Field Technique. General Technical Report RM-245*. Fort Collins, CO: United States Department of Agriculture, Forest Service, Rocky Mountain Forest and Range Experiment Station.  
<http://stream.fs.fed.us/publications/PDFs/RM245E.PDF>
- Hotchkiss, Rollin H. and Christopher M. Frei. 2007. *Design for Fish Passage at Roadway-Stream Crossings: Synthesis Report*. U.S. Department of Transportation, Federal Highway Administration, Office of

- Infrastructure Research and Development. McLean, Virginia. (Publication No. FHWA-HIF-07-033). <http://www.fhwa.dot.gov/engineering/hydraulics/pubs/07033/>
- Jackson, Scott D. et al. 2003. Design and Construction of Aquatic Organism Passage at Road-Stream Crossings: Ecological Considerations in the Design of River and Stream Crossings. In 2003 Proceedings of the International Conference on Ecology and Transportation, edited by C. Leroy Irwin, Paul Garrett, and K.P. McDermott. Raleigh, NC: Center for Transportation and the Environment, North Carolina State University.
- Kilgore, Roger T., Bart S. Bergendahl, and Rollin H. Hotchkiss. 2010. *Culvert Design for Aquatic Organism Passage: Hydraulic Engineering Circular Number 26*. Central Federal Lands Highway Division, Lakewood, Colorado. Report No. FHWA-HIF-11-008 HEC-26.
- Maine DOT. 2004. *Fish Passage Policy and Design Guide*. Maine Department of Transportation. Augusta, Maine.
- Massachusetts Riverways Program. 2005. *Massachusetts Stream Crossings Handbook*. Commonwealth of Massachusetts, Executive Office of Environmental Affairs, Department of Fish and Game. Boston, Massachusetts.
- Massachusetts River Continuity Partnership. 2006. *Massachusetts River and Stream Crossing Standards*.
- MassDEP. 2007. *Dam Removal and the Wetland Regulations*. Massachusetts Department of Environmental Protection, Bureau of Resource Protection, Wetlands/Waterways Program, Boston, Massachusetts.
- MassDOT. 2009 *LRFD Bridge Design Manual*. Massachusetts Department of Transportation. Boston, Massachusetts.
- MassDOT. 2006. *Project Development and Design Guide*. Massachusetts Executive Office of Transportation. Boston, Massachusetts.
- MDEWMA. 2000. *Maryland's Waterway Construction Guidelines*. Maryland Department of the Environment Water Management Administration. Baltimore, Maryland.
- Robison, George E. et al. 1999. *Oregon Road/Stream Crossing Restoration Guide: Advanced Fish Passage Training Version Spring 1999*. Oregon Department of Fish and Wildlife.
- USACE. 2005. Programmatic General Permit, Commonwealth Of Massachusetts.: Effective January 20, 2005. Department of the Army, U.S. Army Corps of Engineers. Concord, Massachusetts.
- USDA Forest Service. *Identifying Bankfull Stage in the Forested Streams in the Eastern United States*. Stream Systems Technology Center. Rocky Mountain Research Station. Fort Collins, Colorado
- VDFW. 2005. *Interim Guidelines for Aquatic Organism Passage through Stream Crossing Structures in Vermont*. Vermont Department of Fish and Wildlife. Montpelier, Vermont.

**Web-sites:**

MA Division of Ecological Restoration, Department of Fish & Game (Riverways Program)	<a href="http://www.mass.gov/dfwele/der/index.htm">http://www.mass.gov/dfwele/der/index.htm</a> (links to a Stream Crossing Handbook published by Riverways, June 2005)
UMass Extension, Stream Continuity program	<a href="http://www.streamcontinuity.org">http://www.streamcontinuity.org</a>
UMass, Natural Resources and Environmental Conservation	<a href="http://www.umass.edu/nrec/fish_wildlife_biodiversity/fish_wildlife_online_docs.html">http://www.umass.edu/nrec/fish_wildlife_biodiversity/fish_wildlife_online_docs.html</a> (resource materials relative to habitat continuity)
USDA Forest Service	<a href="http://www.stream.fs.fed.us/fishxing/">http://www.stream.fs.fed.us/fishxing/</a> (FishXing software for evaluating and designing culverts for fish passage)
USDA Forest Service	<a href="http://www.stream.fs.fed.us/publications/videos.html">http://www.stream.fs.fed.us/publications/videos.html</a> (training CDs for field determination of bankfull parameters)
USDA Forest Service	<a href="http://www.fs.fed.us/eng/pubs/pdf/StreamSimulation/index.shtml">http://www.fs.fed.us/eng/pubs/pdf/StreamSimulation/index.shtml</a> (guidance for Stream Simulation design)
US Army Corps of Engineers, Programmatic General Permit	<a href="http://www.nae.usace.army.mil/reg/index.htm">http://www.nae.usace.army.mil/reg/index.htm</a> (links to MGP and to the Massachusetts Stream Crossing Standards)
Washington Fish and Game Department	<a href="http://wdfw.wa.gov/hab/engineer/habeng.htm">http://wdfw.wa.gov/hab/engineer/habeng.htm</a> (guidance for culvert design for fish passage)





## **Appendix A**

### **Massachusetts River and Stream Crossing Standards**



# Massachusetts River and Stream Crossing Standards

Developed by the

## River and Stream Continuity Partnership

Including:

University of Massachusetts Amherst  
MA Riverways Program  
The Nature Conservancy

March 1, 2006

### INTRODUCTION

Movement of fish and wildlife through river and stream corridors is critical to the survival of individual organisms and the persistence of populations. However, as long and linear ecosystems, rivers and streams are particularly vulnerable to fragmentation. In addition to natural barriers, a number of human activities can, to varying degrees, disrupt the continuity of river and stream ecosystems. The most familiar human-caused barriers are dams. However, there is growing concern about the role of river and stream crossings, and especially culverts, in disrupting river and stream continuity.

Road networks and river systems share several things in common. Both are long, linear features of the landscape. Transporting materials (and organisms) is fundamental to how they both function. Connectivity is key to the continued functioning of both systems. Ultimately, our goal should be to create a transportation network that does not fragment or undermine the essential ecological infrastructure of the land and its waterways.

With funding from the Sweetwater Trust, the Massachusetts Watershed Initiative, and the Massachusetts Riverways Program, the University of Massachusetts–Amherst coordinated an effort to create river and stream crossing standards and a volunteer inventory program for culverts and other crossing structures to more effectively identify and address barriers to fish movement and river and stream continuity. Information was compiled about fish and wildlife passage requirements, culvert design standards, and methodologies for evaluating barriers to fish and wildlife passage.<sup>1</sup> This information was used to develop performance standards for culverts and other stream crossing structures.

---

<sup>1</sup> In developing the Standards the Partnership benefited greatly from work that has been done and materials developed over the years in Washington State, Oregon, California, and Maine, and by the US Forest Service.

The following standards were developed by the River and Stream Continuity Partnership with input from an Advisory Committee that includes representatives from UMass-Amherst, MA Riverways Program, Massachusetts Watershed Initiative, Trout Unlimited, The Nature Conservancy, the Westfield River Watershed Association, ENSR International, Massachusetts Highway Department (MassHighway), and the Massachusetts Departments of Environmental Protection and Conservation and Recreation. In developing the standards, the Partnership received advice from a Technical Advisory Committee that included representatives of the U.S. Fish and Wildlife Service, USGS BRD, U.S. EPA, U.S. Army Corps of Engineers, MA Division of Fisheries and Wildlife, American Rivers, Connecticut River Watershed Council, Connecticut DEP, a hydraulic engineering consultant, as well as input from people with expertise in Stream Simulation approaches to crossing design<sup>2</sup>. The standards are recommended for new permanent crossings (highways, railways, roads, driveways, bike paths, etc.) and, when possible, for replacing existing permanent crossings.

These standards seek to achieve, to varying degrees, three goals:

1. Fish and other Aquatic Organism Passage: Facilitate movement for fish and other aquatic organisms, including relatively small, resident fish, aquatic amphibians & reptiles, and large invertebrates (e.g. crayfish, mussels).
2. River/Stream Continuity: Maintain continuity of the aquatic and benthic elements of river and stream ecosystems, generally through maintenance of appropriate substrates and hydraulic characteristics (water depths, turbulence, velocities, and flow patterns). Maintenance of river and stream continuity is the most practical strategy for facilitating movement of small, benthic organisms as well as larger, but weak-swimming species such as salamanders and crayfish.
3. Wildlife Passage: Facilitate movement of wildlife species including those primarily associated with river and stream ecosystems and others that may utilize riparian areas as movement corridors. Some species of wildlife such as muskrats and stream salamanders may benefit from river and stream continuity. Other species may require more open structures as well as dry passage along the banks or within the streambed at low flow.

There are a few approaches available for designing river and stream crossings. These Crossing Standards are most consistent with a “Stream Simulation” approach for crossing design. Given the large number of species that make up river and stream communities and the almost complete lack of information about swimming abilities and passage requirements for most organisms, it is impractical to use a species-based approach for designing road crossings. The Stream Simulation approach is the most practical way to maintain viable populations of organisms that make up aquatic communities and maintain the fundamental integrity of river and stream ecosystems. Stream Simulation is an ecosystem-based approach that focuses on maintaining the variety and quality of habitats, the connectivity of river and stream ecosystems, and the essential ecological processes that shape and maintain these ecosystems over time.

Stream Simulation is a design approach that avoids flow constriction during normal conditions and creates a stream channel that maintains the diversity and complexity of the streambed through the

---

<sup>2</sup> Special thanks go to Ken Kozmo Bates and Kim Johansen for their review and useful comments on previous drafts of the Crossing Standards.

crossing. Crossing structures that avoid channel constriction and maintain appropriate channel conditions (channel dimensions, banks, bed, and bed forms) within the structure should be able to accommodate most of the normal movements of aquatic organisms, and preserve (or restore) many ecosystem processes that maintain habitats and aquatic animal populations. The goal is to create crossings that are essentially “invisible” to aquatic organisms by making them no more of an obstacle to movement than the natural channel.

These standards are for general use to address issues of river and stream continuity, fish passage and wildlife movement. In some cases, site constraints may make strict adherence to the standards impractical or undesirable. For example, in some situations the road layout and surrounding landscape may make it impossible or impractical to achieve the recommended standards for height and openness. These standards may not be appropriate for highly degraded streams where stream instability may be a serious concern. Site-specific information and good professional judgment should always be used to develop crossing designs that are both practical and effective.

Here are some important considerations to keep in mind when using these standards.

1. They are intended for permanent river and stream crossings. They are not intended for temporary crossings such as skid roads and temporary logging roads.
2. They are generally intended for fish-bearing streams. These standards are not recommended for those portions of intermittent streams that are not used by fish. However, these standards may be useful in areas where fish are not present but where protection of salamanders or other local wildlife is desired. Further, the standards are not intended for constructed drainage systems designed primarily for the conveyance of storm water.
3. These standards were developed with the objective of facilitating fish and wildlife movement and the preservation or restoration of river/stream continuity. They may not be sufficient to address drainage or flood control issues that must also be considered during design and permitting of permanent stream crossings.
4. These standards are not prescriptive. They are intended as conceptual performance standards for river and stream crossings. They establish minimum criteria that are generally necessary to facilitate fish and wildlife movement and maintain river/stream continuity. Use of these standards alone will not satisfy the need for proper engineering and design. In particular, appropriate engineering is required to ensure that structures are sized and designed to provide adequate capacity (to pass various flood flows) and stability (bed, bed forms, footings and abutments).
5. The design of any structure must consider the channel type and long profile and must account for likely variability of the stream or river for the life of the structure. A “long profile” is a surveyed longitudinal profile along the thalweg (deepest portion of the channel) of the stream extending well upstream and downstream of the crossing.
6. In urbanizing environments there is greater potential for land use changes to result in stream instability. Wherever there is potential for stream instability it is important to evaluate stream adjustment potential at the crossing location and to factor this into the design of the structure. (This is true of all crossing structures whether or not they are designed to these standards.)

## DESIGN STANDARDS FOR NEW CROSSINGS

These standards are for new structures at sites where no previous crossing structure existed. Culvert replacements are addressed in the following section “Standards for Culvert Replacement.”

There are two levels of standards (General and Optimum) to balance the cost and logistics of crossing design with the degree of river/stream continuity warranted in areas of different environmental significance.

### General Standards:

**Goal:** Fish passage, river/stream continuity, some wildlife passage

#### *Application*

Where permanent stream crossings are planned on fish bearing streams or rivers, they should at least meet general standards to pass most fish species, maintain river/stream continuity, and facilitate passage for some wildlife.

Fish bearing streams or rivers include rivers and streams that support one or more species of fish<sup>3</sup>, including those portions of intermittent streams that are used seasonally by fish. These standards are also warranted where fish are not present, but where protection of salamanders or other local wildlife species is desired.

General standards call for open bottom structures or culverts that span the river/stream channel with natural bottom substrates that generally match upstream and downstream substrates. Stream depth and velocities in the crossing structure during low-flow conditions should approximate those in the natural river/stream channel. An openness ratio of 0.25 meters will pass some wildlife species but is unlikely to pass all the wildlife that would be accommodated by the optimum standards.

#### *Standards*

1. Bridges are generally preferred, but well designed culverts and open-bottom arches may be appropriate

Site constraints may make the use of bridge spans impractical and in some cases well-designed culverts may actually perform better than bridges (areas with deep soft substrate). However, in areas where site constraints don't limit the usefulness of these structures, bridges are preferred over culverts.

---

<sup>3</sup> These standards would also be appropriate for a portion of a stream where fish were historically present but were lost as a result of migratory barriers when there is a reasonable expectation that fish could be restored to that stream section.

2. If a culvert, then it should be embedded:

- ≥ 2 feet for box culverts and other culverts with smooth internal walls,
- ≥ 1 foot for corrugated pipe arches
- ≥ 1 foot and at least 25 percent for corrugated round pipe culverts

These minimum embedment depths should be sufficient for many culverts. However, circumstances may dictate a need for deeper substrates that are based on site specific analysis. These include high gradient streams and streams experiencing instability or with potential instability that could result in future adjustments to channel elevation. In these cases long profiles and calculations of potential channel adjustments should be used to determine embedment depth.

The intent of this standard is to provide for:

- Sufficient depth of material within the culvert to achieve stability of the culvert bed material comparable to that of the upstream and downstream channel;
- Sufficient depth of material to permit shaping of material to achieve natural depths of flow at low-flow conditions; and
- Sufficient embedment to account for long-term vertical channel adjustment anticipated for the adjacent stream bed.

In some cases site constraints may limit the degree to which a culvert can be embedded. In these cases pipe culverts should not be used and pipe arches, open-bottom arches, or bridges should be considered instead.

Use scour analyses to determine footing depths for open-bottom arches, open-bottom boxes and bridges.

3. Spans channel width (a minimum of 1.2 times the bankfull width)

It is critical to avoid channel constriction during normal bankfull flows. A width of 1.2 times bankfull width is the minimum width needed to meet these standards. Bankfull width should be determined as the average of at least three typical widths, ideally measured at the proposed structure's location, and then upstream and downstream of the proposed structure (except where stream sections are not representative of conditions where the structure will be located). The stream width should be measured at straight sections of the channel outside the influence of existing structures and unusual channel characteristics. The structure should not be narrower than the bankfull width at the crossing location.

In constricted channels 1.2 times bankfull may also be adequate for passing large, infrequent storm events and maintaining stability of both the structure and channel. However, this should be verified through standard engineering practices and calculations.

For streams within floodplains, a clear span of 1.2 times bankfull may not be sufficient to ensure adequate water conveyance for large, infrequent flood events without destabilizing the stream channel. In these cases, wider structures or alternative means of conveying flood waters may be necessary. It is critically important that structure design on these streams be based on sound engineering.

4. Natural bottom substrate within the structure

Careful attention must be paid to the composition of the substrate within the culvert. The substrate within the structure should match the characteristics of the substrate in the natural stream channel (mobility, slope, stability, confinement) at the time of construction and over time as the structure has had the opportunity to pass significant flood events.

The substrate should resist displacement during flood events and be designed to maintain appropriate channel characteristics through natural bed load transport. Sometimes in order to ensure bed stability (stability is not the same as rigidity) at higher than bankfull flows it may be necessary to use larger substrate within the structure than is generally found in the natural stream channel. In these cases the substrate should approximate the natural stream channel and fall within the range of variability seen in the natural channel upstream and downstream of the crossing.

5. Designed with appropriate bed forms and streambed characteristics so that water depths and velocities are comparable to those found in the natural channel at a variety of flows

In order to provide appropriate water depths and velocities at a variety of flows and especially low flows it is usually necessary to reconstruct the streambed or preserve the natural channel within the structure. Otherwise, the width of the structure needed to accommodate higher flows will create conditions that are too shallow at low flows. When constructing the streambed special attention should be paid to the sizing and arrangement of materials within the structure. If only large material is used, without smaller material filling the voids, there is a risk that flows could go subsurface within the structure.

6. Openness ratio > 0.25 meters

Openness ratio is the cross-sectional area of a structure opening (in square meters) divided by its crossing length when measured in meters. For a box culvert, openness = (height x width)/length. For crossing structures with multiple cells or barrels, openness ratio is calculated separately for each cell or barrel. At least one cell or barrel should meet the appropriate openness ratio standard. Embedded portions of culverts are not included in the calculation of cross-sectional area for determining openness ratio.<sup>4</sup>

## Optimum Standards

**Goal:** Fish passage, river/stream continuity, wildlife passage

**Application**

Where permanent stream crossings occur or are planned in areas of particular statewide or regional significance for their contribution to landscape level connectedness or river/stream ecosystems that provide important aquatic habitat for rare or endangered species, optimum standards should be applied in order to maintain river/stream continuity and facilitate passage for fish and wildlife.

---

<sup>4</sup> An Embedded Area Spreadsheet developed by the U.S. Army Corps of Engineers shows how to calculate the open area for embedded pipe culverts to meet the 0.25 standard for openness ratio. The spreadsheet can be downloaded from the Online Documents section of [www.streamcontinuity.org](http://www.streamcontinuity.org).



Areas of particular statewide or regional significance for their contribution to landscape level connectedness include, but are not limited to, rivers/streams and associated riparian areas that serve as corridors or connecting habitat linking areas of significant habitat (>250 acres) in three or more towns.

Important aquatic habitat for rare or endangered species includes, but is not limited to, those river and stream segments identified by the Natural Heritage and Endangered Species Program (via the Living Waters or Biomap projects or regulatory review) that are considered important for protecting rare or endangered species.

Where permanent stream crossings occur or are planned in areas of high connectivity value – areas of particular statewide or regional significance for their contribution to landscape level connectedness – crossings should be designed to maintain river/stream continuity and facilitate passage for fish and wildlife. The best designs for accomplishing this involve open bottom structures or bridges that not only span the river/stream channel, but also span one or both of the banks allowing dry passage for wildlife that move along the watercourse. Where the crossing involves high traffic volumes or physical barriers to wildlife movement, the crossing structure should be sized to pass most wildlife species (minimum height and openness requirements).

### ***Standards***

#### ***1. Use bridge spans***

Unless there are compelling reasons why a culvert would provide greater environmental benefits only bridges should be used.

#### ***2. Span the streambed and banks***

The structure span should be at least 1.2 times the bankfull width and provide banks on one or both sides with sufficient headroom to provide dry passage for semi-aquatic and terrestrial wildlife.

For streams within floodplains 1.2 times bankfull may not be sufficient to ensure adequate water conveyance for large, infrequent flood events without destabilizing the stream channel. In these cases, wider structures or alternative means of conveying flood waters may be necessary. It is critically important that structure design on these streams be based on sound engineering.

The structure should be designed to allow dry passage (along banks or dry streambed) at least 90% of the year.

#### ***3. Natural bottom substrate within the structure***

Careful attention must be paid to the composition of the substrate within the culvert. The substrate within the structure should match the characteristics of the substrate in the natural stream channel (mobility, slope, stability, confinement) at the time of construction and over time as the structure has had the opportunity to pass significant flood events.

The substrate should resist displacement during flood events and be designed to maintain appropriate channel characteristics through natural bed load transport. Sometimes in order to ensure bed stability (stability is not the same as rigidity) at higher than bankfull flows it may be

necessary to use larger substrate within the structure than is generally found in the natural stream channel. In these cases the substrate should approximate the natural stream channel and fall within the range of variability seen in the natural channel upstream and downstream of the crossing.

4. Designed with appropriate bed forms and streambed characteristics so that water depths and velocities are comparable to those found in the natural channel at a variety of flows

In order to provide appropriate water depths and velocities at a variety of flows and especially low flows it is usually necessary to reconstruct the streambed or preserve the natural channel within the structure. Otherwise, the width of the structure needed to accommodate higher flows will create conditions that are too shallow at low flows. When constructing the streambed special attention should be paid to the sizing and arrangement of materials within the structure. If only large material is used, without smaller material filling the voids, there is a risk that flows could go subsurface within the structure.

5. Maintain a minimum height of 6 ft (1.8 meters) and openness ratio of 0.75 meters if conditions are present that significantly inhibit wildlife passage (high traffic volumes, steep embankments, fencing, Jersey barriers or other physical obstructions)

Height should be measured from the average invert of the stream bed within the structure to the inside top of the structure.

Openness ratio is the cross-sectional area of a structure (in square meters) divided by its crossing length when measured in meters. For a box culvert, openness = (height x width)/length. For crossing structures with multiple cells or barrels, openness ratio is calculated separately for each cell or barrel (do not add together the cross-sectional areas of multiple cells or barrels). At least one cell or barrel should achieve the appropriate openness ratio. The embedded portion of culverts is not included in the calculation of cross-sectional area for determining openness ratio.

6. If conditions that significantly inhibit wildlife passage are not present, maintain a minimum height of 4 ft. (1.2 meters) and openness ratio of 0.5 meters

## DESIGN STANDARDS FOR CULVERT REPLACEMENT

Given the number of culverts and other crossing structures that have been installed without consideration for ecosystem protection, it is important to assess what impact these crossings are having and what opportunities exist for mitigating those and future impacts. In the short term some barriers can be addressed by culvert retrofits: temporary modifications to improve aquatic organism passage short of replacement. However, culvert replacement and remediation generally offer the best opportunity for restoring continuity and long-term protection of river and stream ecosystems.

Methods have been developed, and are continuing to be refined and adapted, for evaluating culverts and other crossing structures for their impacts on animal passage and other ecosystem processes. Along with these assessments there needs to be a process for prioritizing problem crossings for remediation. The process should take into account habitat quality in the river or stream and surrounding areas, upstream and downstream conditions, as well as the number of other crossings, discontinuities (channelized or piped sections), and barriers affecting the system. It is important to use a watershed-based approach to river and stream restoration in order to maximize positive outcomes and avoid unintended consequences.

Culvert upgrading requires careful planning and is not simply the replacement of a culvert with a larger structure. Even as undersized culverts block the movement of organisms and material, over time, rivers and streams adjust to the hydraulic and hydrological changes caused by these structures. Increasing the size of a crossing structure can destabilize the stream and cause head cutting – the progressive down-cutting of the stream channel – upstream of the crossing. There also may be downstream effects such as increased sedimentation. Crossing replacement can result in the loss or degradation of wetlands that formed above the culvert as a consequence of constricted flow. In more developed watersheds, undersized culverts may play an important role in regulating storm flows and preventing flooding.

Before replacing a culvert or other crossing structure with a larger structure it is essential that the replacement be evaluated for its impacts on:

- downstream flooding,
- upstream and downstream habitat (instream habitat, wetlands),
- potential for erosion and headcutting, and
- stream stability.

In most cases it will be necessary to conduct engineering analyses including long profiles of sufficient length to understand potential changes in channel characteristics. A “long profile” is a surveyed longitudinal profile along the thalweg (deepest portion of the channel) of the stream extending well upstream and downstream of the crossing. The replacement crossing will need to be carefully designed in order to maximize the benefits and minimize the potential for negative consequences resulting from the upgrade. In many instances, some stream restoration will be needed in addition to culvert replacement in order to restore river/stream continuity and facilitate fish and wildlife passage.

Culvert replacements will need to be reviewed and permitted either by either the local conservation commission, the Massachusetts Department of Environmental Protection (§401 Water Quality Certification), the US Army Corp of Engineers, or a combination of the three.

## ***Standards***

1. *Whenever possible replacement culverts should meet the design guidelines for either general standards or optimal standards (see Standards for New Crossings above)*
2. *If it is not possible or practical to meet all of the General or Optimal standards, replacement crossings should be designed to:*
  - a. *Meet the General Standards for crossing width (1.2 times bankfull width)*
  - b. *Meet other General Standards to the extent practical, and*
  - c. *Avoid or mitigate the following problems*
    - *Inlet drops*
    - *Outlet drops*
    - *Flow contraction that produces significant turbulence*
    - *Tailwater armoring*
    - *Tailwater scour pools*
    - *Physical barriers to fish passage*
3. *As indicated by long profiles, scour analyses and other methods, design the structure and include appropriate grade controls to ensure that the replacement will not destabilize the river/stream*
4. *To the extent practicable conduct stream restoration as needed to restore river/stream continuity and eliminate barriers to aquatic organism movement*
5. *Avoid High Density Polyethylene Pipes (HDPP) or plastic pipes*

High Density Polyethylene Pipes, especially smooth bore, or plastic pipes shall not be installed. The inherent hydraulic characteristics (low friction coefficient) of HDPP are not conducive to passing aquatic life.

## CONSTRUCTION BEST MANAGEMENT PRACTICES

Construction of road-stream crossings has the potential to generate significant adverse impacts to rivers and streams. Use of appropriate construction methods and best management practices (BMPs) are essential for meeting design standards and avoiding unnecessary impacts to water and habitat quality. Following are a list of BMPs that should be considered.<sup>5</sup>

**Road and Crossing Location.** Roads should be planned to avoid or minimize the number of road-stream crossings. Where crossings cannot be avoided they should be located in areas that will minimize impacts. Here are some rules of thumb.

- Avoid sensitive areas such as rare species habitat and important habitat features (vertical sandy banks, underwater banks of fine silt or clay, deep pools, fish spawning habitat).
- Avoid unstable or high-hazard locations such as steep slopes, wet or unstable slopes, non-cohesive soils, and bordering vegetated wetlands. Alluvial reaches are poor locations for road-stream crossings.
- Where possible locate crossings on straight channel segments (avoid meanders)
- To the extent possible align crossings perpendicular to the stream channel

**Timing of Construction.** In general the most favorable time for constructing road-stream crossings is during periods of low flow, generally July 1 to October 1. However, there may be occasions when a particular stream or river supports one or more rare species that would be particularly vulnerable to disturbances during low-flow conditions. Where rare species are a concern, contact the Massachusetts Natural Heritage and Endangered Species Program (NHESP) for information and advice on how to minimize impacts to those species. Such consultations are required for crossings that would affect areas of Priority Habitat identified by NHESP.

### Dewatering

- Minimize the extent and duration of the hydrological disruption
- Consider the use of bypass channels to maintain some river and stream continuity during construction
- Use dams to prevent backwatering of construction areas
- Gradually dewater and rewater river and stream segments to avoid abrupt changes in stream flow
- Salvage aquatic organisms (fish, salamanders, crayfish, mussels) stranded during dewatering
- Segregate clean diversion water from sediment-laden runoff or seepage water
- Use anti-seep collars around diversion pipes
- Use upstream sumps to collect groundwater and prevent it from entering the construction site
- Collect construction drainage from groundwater, storms, and leaks and treat to remove sediment
- Use downstream sediment control sump to collect water that seeps out of the construction area

---

<sup>5</sup> Much of the following information about construction BMPs comes from training materials used as part of the U.S. Forest Service's Aquatic Organism Passage project and that will be included in an upcoming Forest Service publication "Stream Simulation: An Ecological Approach to Road-Stream Crossings."

- Use fish screens around the intake of diversion pipes
- Use appropriate energy dissipaters and erosion control at pipe outlets
- When using diversion pipes make sure adequate pumping capacity is available to handle storm flows

### **Stormwater Management, Erosion and Sediment Control**

- Minimize bare ground
- Minimize impact to riparian vegetation
- Prevent excavated material from running into water bodies and other sensitive areas
- Use appropriate sediment barriers (silt fence, hay bales, mats, Coir logs)
- Dewater prior to excavation
- Manage and treat surface and groundwater encountered during excavation with the following
  - sediment basins
  - fabric, biobag or hay bale corals
  - irrigation sprinklers or drain pipes discharging into vegetated upland areas
  - sand filter
  - geotextile filter bags
- Turbidity of water 100-200 feet downstream of the site should not be visibly greater than turbidity upstream of the project site.

### **Pollution Control**

- Wash equipment prior to bringing to the work area to remove leaked petroleum products and avoid introduction of invasive plants
- To avoid leaks, repair equipment prior to construction
- Be prepared to use petroleum absorbing “diapers” if necessary
- Locate refueling areas and hazardous material containment areas away from streams and other sensitive areas
- Establish appropriate areas for washing concrete mixers; prevent concrete wash water from entering rivers and streams
- Take steps to prevent leakage of stockpiled materials into streams or other sensitive areas (locate away from water bodies and other sensitive areas, provide sediment barriers and traps, cover stockpiles during heavy rains)

### **Construction of Stream Bed and Banks within Structures**

- Check construction surveys to ensure slopes and elevations meet design specifications
- Use appropriately graded material (according to design specifications) that has been properly mixed before placement inside the structure
- Avoid segregation of bed materials
- Compact bed material
- After the stream bed has been constructed wash bed material to ensure that fine materials fill gaps and voids

- Construct an appropriate low-flow channel and thalweg
- Carefully construct bed forms to ensure functionality and stability
- Construct well-graded banks for roughness, passage by small wildlife, and instream bank-edge habitat
- Tie constructed banks into upstream and downstream banks

### **Soil Stabilization and Re-vegetation**

- Surface should be rough to collect seeds and moisture
- Implement seeding and planting plan that addresses both short term stabilization and long term restoration of riparian vegetation
- Water vegetation to ensure adequate survival
- Use seed, mulch, and/or erosion control fabrics on steep slopes and other vulnerable areas
- Avoid jute netting and other erosion control materials that contain mesh near streams or rivers (have been known to trap and kill fish and wildlife)
- Use native plants unless other non-invasive alternatives will yield significantly better results

### **Monitoring**

- Ensure that BMPs are being implemented
- Inspect for erosion
- Evaluate structure stability
- Inspect for evidence of stream instability
- Inspect for presence of debris accumulations or other physical barriers at or within crossing structures
- Ensure streambed continuity is maintained
- Inspect for problems with infiltration in constructed stream beds (subsurface flows)
- Inspect for scouring of the streambed downstream or the aggradation of sediment upstream of the structure

## GLOSSARY

- **Bankfull Width** – Bankfull is a geometric parameter that corresponds with the amount of water that just fills the stream channel and where additional water would result in a rapid widening of the stream or overflow into the floodplain. Indicators of Bankfull width include:
  - Abrupt transition from bank to floodplain. The change from a vertical bank to a horizontal surface is the best identifier of the floodplain and Bankfull stage, especially in low-gradient meandering streams.
  - Top of pointbars. The pointbar consists of channel material deposited on the inside of meander bends. Set the top elevation of pointbars as the lowest possible Bankfull stage.
  - Bank undercuts. Maximum heights of bank undercuts are useful indicators in steep channels lacking floodplains.
  - Changes in bank material. Changes in soil particle size may indicate the operation of different processes. Changes in slope may also be associated with a change in particle size.
  - Change in vegetation. Look for the low limit of perennial vegetation on the bank, or a sharp break in the density or type of vegetation.
  
- **Bed Adjustment Potential** – Potential change in the elevation, width, depth, slope or meander pattern of the stream channel as it adjusts to a source of stream instability (changes in discharge, sediment supply, or base elevation). Instability may be caused by changes at a stream crossing site or conditions upstream or downstream of the crossing site or within the watershed (urbanization).
  
- **Bedforms** – Natural bedforms include isolated boulders, particle clusters, steps, pools, head of riffles and pool tail crests, large woody debris, transverse bars, longitudinal ribs, and gravel bars. Constructed bedforms may include any of the above as well as rock and log weirs and roughened channels.
  
- **Conditions that significantly inhibit wildlife passage** – These include high traffic volumes, steep embankments, fencing, Jersey barriers or other physical obstructions that prevent wildlife passage over the road surface
  
- **Culvert** – As used in these Standards, culverts are round, elliptical or rectangular structures that are fully enclosed (contain a bottom) designed primarily for channeling water beneath a road, railroad or highway. Bottomless structures, though sometimes considered culverts by others, are treated separately in these Standards.
  
- **Embedded Culvert** – A culvert that is installed in such a way that the bottom of the structure is below the stream bed and there is substrate in the culvert.
  
- **Flow contraction** – When a culvert or other crossing structure is significantly smaller than the stream width the converging flow creates a condition called “flow contraction.” The increased



velocities and turbulence associated with flow contraction can block fish and wildlife passage and scour bed material out of a crossing structure. Flow contraction also creates inlet drops.

- **Inlet drop** – Where water level drops suddenly at an inlet, causing changes in water speed and turbulence. In addition to the higher velocities and turbulence, these jumps can be physical barriers to fish and other aquatic animals when they are swimming upstream and are unable to swim out of the culvert.
- **Long Profile** – A long profile is a surveyed longitudinal profile along the thalweg (deepest portion of the channel) of the stream extending well upstream and downstream of the crossing.
- **Open Bottom Arch** – Arched crossing structures that span all or part of the stream bed, typically constructed on buried footings and without a bottom.
- **Openness ratio** – Equals cross-sectional area of the structure opening (in square meters) divided by crossing length when measured in meters. For a box culvert, openness = (height x width)/ length. For crossing structures with multiple cells or barrels, openness ratio is calculated separately for each cell or barrel (do not add together the cross-sectional areas of multiple cells or barrels). At least one cell or barrel should achieve the appropriate openness ratio. The embedded portion of culverts is not included in the calculation of cross-sectional area for determining openness ratio.
- **Outlet drop** – An outlet drop occurs when water drops off or cascades down from the outlet, usually into a receiving pool. This may be due to the original culvert placement, erosion of material at the area immediately downstream of the culvert, or downstream channel adjustments that may have occurred subsequent to the culvert installation. Outlet drops are barriers to fish and other aquatic animals that can't jump to get up into the culvert.
- **Physical barriers to fish and wildlife passage** – Any feature that physically blocks fish or wildlife movement through a crossing structure as well as features that would cause a crossing structure to become blocked. Beaver dams, debris jams, fences, sediment filling culvert, weirs, baffles, aprons, and gabions are examples of structures that might be or cause physical barriers. Weirs are short dams or fences in the stream that constrict water flow or fish movements. Baffles are structures within culverts that direct, constrict, or slow down water flow. Gabions are rectangular wire mesh baskets filled with rock that are used as retaining walls and erosion control structures. Steeply sloping channels within a structure resulting in shallow flows and/or high velocity flows can also inhibit movement of fish and other aquatic organisms.
- **Pipe Arch** – A pipe that departs from a circular shape such that the width (or span) is larger than the vertical dimension (or rise), and forms a continuous circumference pipe that is not bottomless.
- **River/Stream Continuity** – Maintaining undisrupted the aquatic and benthic elements of river and stream ecosystems, generally through maintenance of appropriate substrates and hydraulic characteristics (water depths, turbulence, velocities, and flow patterns)

- **Stream Simulation** – A design method in which the diversity and complexity of the natural streambed are created inside a culvert, open-bottom arch, or open-bottom box in such a way that the streambed maintains itself across a wide range of flows. The premise is that if streambed morphology is similar to that in the natural channel the crossing will be invisible to aquatic species.
- **Tailwater armoring** – Concrete aprons, plastic aprons, riprap or other structures added to culvert outlets to facilitate flow and prevent erosion.
- **Tailwater scour pool** – A pool created downstream from high flows exiting the culvert. The pool is wider than the stream channel and banks are typically eroded. Some plunge pools may have been specifically designed to dissipate flow energy at the culvert outlet and control downstream erosion.
- **Thalweg** – A line connecting the lowest points of a stream or river bed.

## NOTES AND REFERENCES

### Stream Simulation

An important source of information in this document comes from training materials used as part of the U.S. Forest Service's Aquatic Organism Passage (AOP) project. "*Stream Simulation: An Ecological Approach to Road-Stream Crossings*" is a detailed manual currently in preparation by the Forest Service that will likely be available sometime in 2006.

Another important reference for Stream Simulation is "*Design of Road Culverts for Fish Passage*" published by the Washington Department of Fish and Wildlife (2003). This may be downloaded from the following web site: <http://wdfw.wa.gov/hab/engineer/cm/>

### Openness Ratio

There is both published and anecdotal evidence from a variety of sources that some animals (including fish) may be reluctant to enter structures that appear too confining. The occurrence of dead turtles, beavers, muskrat and other riverine animals on roadways above or near road-stream crossings suggests that certain structures may be too small or too confining to accommodate some wildlife.

The inverse of confinement is the concept of openness: the size of a structure opening relative to its length. Openness ratio is defined as the cross-sectional area of the structure opening (in square meters) divided by crossing length measured in meters.

Unfortunately, there is little information available on the openness requirements for fish and wildlife. Reed et al. (1979) concluded that 0.6 is the minimum openness ratio needed for mule and whitetail deer to use a structure. In a study of box culverts in Pennsylvania the average openness ratio for structures used by deer was 0.92 with a range of 0.46 to 1.52 (Brudin 2003). A report from the Netherlands cites data indicating that crossing structures with openness ratios < 0.35 were never used by deer while structures with openness ratios > 1.0 were always used (The Netherlands Ministry of Transport 1995).

Although there are no data or studies available on the openness requirements for species other than deer, we chose to include openness ratio as one of the standards in order to ensure some minimum level of openness. The openness standard of 0.25 in the general standards is well below that required by deer. However, it is hoped that it will be minimally sufficient for fish and small riverine wildlife species. For most roadways, the openness ratio in the optimum standards (0.50) also falls below that generally required by deer. Only when applying the optimum standards under conditions that would inhibit wildlife passage over the road surface (Jersey barriers, fencing, high traffic volumes) does the openness standard (0.75) fall within the range of values for deer. It is hoped that an openness ratio of 0.75 also will be sufficient for other large mammals such as moose and bear.

Brudin, C.O. 2003. Wildlife Use of Existing Culverts and Bridges in North Central Pennsylvania. Pp. 344-352 In 2003 Proceedings of the International Conference on Ecology and

Transportation, edited by C. Leroy Irwin, Paul Garrett, and K.P. McDermott. Raleigh, NC: Center for Transportation and the Environment, North Carolina State University, 2003..

Ministry of Transport, P. W. and W. M. 1995. Wildlife Crossings for Roads and Waterways. Road and Hydraulic Engineering Division, Ministry of Transport, Public Works and Water Management, Delft, The Netherlands.

Reed, D.F., T.N. Woodard, and T.D. Beck. 1979. Regional Deer-Vehicle Accident Research. Federal Highway Administration. Rep. No. FHWA-RD-79-11.

Reed, D.F. 1981. Mule deer behavior at a highway underpass exit. *J. Wildl. Manage* 45(2):542-543.

## **Appendix B**

### **MassDOT Stream Crossing Structures Rating Chart and Related Information**



### MassDOT Stream Crossing Structures Rating Chart – Part 1

Screening Level 1		
Does the culvert/bridge have any of the following conditions?	Yes	No
Drop in inlet water elevation > 6 inches		
Outlet drop (perching) > 6 inches		
Flow contraction at inlet under base flows resulting in turbulence or in a water elevation drop > 6 inches		
Extensive tail water armoring (e.g., concrete or other synthetic apron, extensive riprap that is dissimilar to natural channel conditions)		
Other permanent physical barriers (e.g., fences, weirs, cross pipes, concrete aprons or channel extensions, weirs, check dams)		
If the answer is “yes” to any of these conditions, the <b>Crossing Rating = 0.</b>		

If none of these conditions is present, proceed to Screening Level 2.

Screening Level 2		
Parameter	Scoring value	Score (enter applicable value)
Limited tail water armoring: <ul style="list-style-type: none"> <li>• Armoring present, but not extensive</li> <li>• No armoring, or riprap similar in size and gradation to natural channel material</li> </ul>	5 10	
Temporary physical barriers <ul style="list-style-type: none"> <li>• Temporary barriers present e.g., beaver dams, debris dams, sediment accumulation</li> <li>• No barriers</li> </ul>	5 10	
Scour pool (wider than natural stream pools, banks eroded) <ul style="list-style-type: none"> <li>• Large (width or depth &gt; twice that of natural pools)</li> <li>• Small (width or depth ≤ twice that of natural pools)</li> <li>• None = 10</li> </ul>	0 5 10	
Embedment <ul style="list-style-type: none"> <li>• Not embedded</li> <li>• Partially embedded</li> <li>• Fully embedded &lt; 1'</li> <li>• Clear span, or Fully embedded ≥ 1'</li> </ul>	0 3 7 10	
Water depth <ul style="list-style-type: none"> <li>• Not comparable to natural channel</li> <li>• Comparable</li> </ul>	0 10	
Water Velocity <ul style="list-style-type: none"> <li>• Not comparable to natural channel</li> <li>• Comparable</li> </ul>	0 10	
<b>Total Score</b>	(10 min. 60 max.)	
If Total Score < 60, proceed to Screening Level 3A. If Total Score = 60, proceed to Screening Level 3B.		

**MassDOT Stream Crossing Structures Rating Chart – Part 2**

<b>Screening Level 3A (Level 2 score &lt; 60)</b>		
<b>Parameter</b>	<b>Scoring value</b>	<b>Score</b>
Score from Screening Level 2		
Substrate (bed material within culvert/bridge, compared to channel) <ul style="list-style-type: none"> <li>• Inappropriate (e.g., none, concrete rubble, completely different)</li> <li>• Contrasting (size/gradation significantly different)</li> <li>• Comparable</li> </ul>	0 5 10	
<b>Total cumulative score</b>		
If Total Cumulative Score is 10 to 34, <b>Crossing Rating = 1</b> If Total Cumulative Score is 35 to 67, <b>Crossing Rating = 2</b>		

<b>Screening Level 3B (Level 2 Score = 60)</b>			
<b>Parameter</b>			<b>Crossing Rating</b>
Substrate (bed material within culvert/bridge) <ul style="list-style-type: none"> <li>• Inappropriate (e.g., none, concrete rubble, completely different)</li> <li>• Contrasting (size/gradation significantly different)</li> <li>• If Comparable – go to next parameter</li> </ul>			2 3 ----
Span	Openness Ratio (feet)	Height (feet)	
• Constricts channel	---	---	4
• Equal to active channel	---	---	5
• Bankfull channel	<0.82	---	5
	0.82 to 1.63	---	6
	1.64 to 2.46	---	7
	>2.46	---	8
• ≥ 1.2 x bankfull channel	<0.82	---	5
	0.82 to 1.63	---	7
	1.64 to 2.46	< 6	8
		≥ 6	9
	>2.46	< 6	8
		≥ 6	10

**Rating as determined above is used in the Passage Classification Table, see next page.**



### Passage Classification for Existing Stream Crossing Structures

Crossing Rating	Passage Classification	Remarks
0 to 1	Severe Barrier	The structure is considered a barrier to most aquatic and terrestrial wildlife.
2	Moderate Barrier	The structure may provide some passage for aquatic wildlife, and is likely a barrier to terrestrial wildlife. Further investigation is required to determine the extent to which it provides aquatic passage.
3 to 5	Minor Barrier	The structure is likely to provide aquatic wildlife passage, but has limited capacity for non-aquatic species.
6 to 8	Meets General Standards	The structure provides aquatic and terrestrial passage consistent with the General Standards of the Massachusetts River and Stream Crossing Standards. <sup>1</sup>
9 to 10	Meets Optimum Standards	The structure provides aquatic and terrestrial passage consistent with the Optimum Standards of the Massachusetts River and Stream Crossing Standards.

---

<sup>1</sup> Structures with a Rating Score of "8" may meet optimum standards where reduced openness (>1.64 feet (0.5 meter)) and height (>4 feet (1.2 meters)) requirements are applicable.



**Appendix B  
Supplemental Information**

**Massachusetts River and Stream Continuity Partnership  
Stream Crossing Inventory Form and Instructions**



## River and Stream Continuity Project

### Instruction Guide for Field Data Form: Road – Stream Crossing Inventory

#### OVERVIEW

The River and Stream Continuity Project is a program that trains volunteers and technicians to inventory river and stream road crossings (culverts, bridges, etc.). This information will be used to help determine if crossings are a barrier to fish and wildlife movement, and cause habitat fragmentation. Barriers that are identified can then be prioritized for remediation.

These instructions provide additional explanations for the questions on the Road – Stream Crossing Inventory Field Data Form. Remember that the data form is for the entire river or stream crossing, which might include multiple culverts or multiple cell bridges. With the exception of dimensions, answer each question for the crossing as a whole. For example, if one culvert at a multiple culvert crossing is fully embedded, then check “fully embedded” on the data form. It is not necessary that every cell of a multiple cell bridge crossing span the channel. Look instead to determine whether, for example, the combination of cells collectively spans the stream channel.

It can be difficult to determine how best to evaluate multiple culvert/cell crossings. Please use the following as a guide for these inherently confusing situations.

1. When the multiple culverts/cells are similar in material, size and elevation use the best case for answering questions on page one of the crossing form. For example if a crossing has two similar sized culverts and where only one of the culverts contains substrate that is comparable to that found in the natural stream channel and the other does not, then answer “comparable” to question #12 (Crossing substrate).
2. When the culverts/cells are significantly different in either material, size, elevation or other characteristics then focus the review on the structure that carries most of the stream flow.
3. When the culverts/cells are significantly different but no single structure carries the majority of the stream flow then focus the review on the “best case” structure considering the full range of characteristics on the data form. If it is not clear which structure is the “best case” structure then consult with the survey coordinator.

***Please be sure to answer every question.***

#### SHADED BOXES

The Survey Coordinator will provide the necessary information for these boxes. These include “Coordinator,” “Crossing ID#,” “Stream/River,” “Road,” “Town” and “Flow condition” as well as information related to entering and reviewing data in the Crossings Database. *Do not enter data in these boxes.*

#### BASIC INFORMATION

GPS Coordinates (lat/long) – Use of a GPS (Global Positioning System) unit is required.

- Set GPS units to lat/long and either WGS84 or NAD1983.
- Coordinates should be collected in decimal degrees with a minimum of four and maximum of five decimal places. Coordinates may be collected and entered on the data sheet as

degrees, minutes and seconds. These will then be converted to decimal degrees prior to entry in the Crossings Database.

- If coordinates are collected in decimal degrees then check the “Decimal degrees” check box and enter coordinates in the spaces provided.
- If coordinates are collected in degrees, minutes and seconds then check the “Degrees, minutes, seconds” check box and enter coordinates in the spaces provided.

Date – Date that the crossing was evaluated.

Location – Provide enough information about the exact location of the crossing so that another person using your data sheet will be confident that they are at the same crossing that you evaluated. For example “between telephone poles # 162 and 163” or “right across from the Depot Restaurant.”

Observer – Your name.

Photo IDs – If you took digital photos record the ID numbers from your camera. Enter “none” if you did not take photos.

Digital photographs are an extremely useful tool to use in assessing potential barriers to aquatic organism passage. When taking photos, be sure to use the date/time stamp to code each photo if possible, and record the ID number from the camera of each photo in the appropriate blank on the form. It is important to set the camera to record in low to medium resolution so that the photos do not take up too much space when downloaded for storage. Ideally, to minimize storage space required, but still allow a reasonable image, each photo would be between 100 and 500 kilobytes in size when downloaded.

You can take and submit to the survey coordinator as many photographs as it takes to thoroughly document the site. Only two photographs from each site can be uploaded to the database. Please ensure that you have one good photo of the inlet taken from upstream of the crossing and another of the outlet taken from downstream of the crossing.

A simple way to know which photos were taken at a particular site is to use a black marker to write the date, crossing ID # and inlet/outlet on a dry-erase board or an 8 ½”X11” paper (waterproof if available). The white board should be strategically placed in the photo to make it legible and to not block key features of the crossings. This will make the photo readily identifiable with the appropriate crossing # and will denote whether the image is of the outlet or inlet of the structure. Some people have noted that white dry-erase boards and white paper reflect so much light that they are often “washed out” in the photos and the codes written on the board impossible to read. Use of a small blackboard and chalk may be preferable depending on light conditions.

## **ROAD /RAILWAY CHARACTERISTICS**

Road surface - Check “Paved” or “Unpaved.”

Road type – Check the most appropriate box for the type of road at the crossing location.

1-Lane road – Check this option for one-lane roads and smaller, including cart paths, bike paths, trails, and abandoned rail beds. If the road is greater than 18 feet wide it should be considered a 2-lane road.

2-Lane road – Use this option for typical roads – with or without shoulders/breakdown lanes – that have two travel lanes. Include in this category unpaved roads that are of comparable width to paved, two-lane roads.

Multilane road – This category includes roadways with three or more travel lanes but not divided highways.

Divided highway – Include any divided highway with a total of four or more travel lanes (e.g. two lanes eastbound + two lanes westbound). Any multi-lane (>2 lanes) roadway with a median, vegetated island, Jersey barriers, or guardrails should be considered a divided highway. When travel lanes are separated by a median you can get two crossings (e.g. one for eastbound and one for west bound traffic). Where you have a divided highway but no median you often get a single crossing. In both cases, the road type should be “divided highway.”

Railroad – Use this category for rail beds with railroad tracks regardless of how many sets of tracks may be involved. Use “1-Lane road” for abandoned rail beds and rail trails.

## CROSSING / STREAM CHARACTERISTICS

Crossing type - Check the most appropriate choice among ford, bridge, open bottom arch, single culvert, multiple culverts to determine crossing type (for additional information see descriptions in the glossary). For an open-bottom box culvert check “bridge.”

Condition of crossing – Check the appropriate box: “excellent,” “fair” or “poor.”

Does the stream at the crossing support fish? – Check “Yes” if you see fish or believe that the stream segment at the crossing supports fish. Also check “Yes” if you think that the stream both above and below the crossing supports fish. Check “Not likely” if you think that it is almost certain that the stream segment does not support fish (including fish just passing through). Otherwise check “Don’t know.”

Is the stream flowing? – Check “Yes” if stream is flowing in the channel upstream and downstream of the crossing. To answer “yes” water in the channel must be moving (even if very slow) and consistent. Puddled areas separated by dry land and rocks does not constitute flow.

Structure height at low water – (from water level to the roof inside the structure). Measure (or if necessary, estimate) the height of the structure at its highest point over the water and record the measurement (in feet). Check the appropriate box to indicate whether the height was measured or estimated.

Inlet drop: Where water level drops suddenly at the crossing inlet, causing changes in water speed and turbulence. In addition to the higher velocities and turbulence, these jumps can be physical barriers to fish and other aquatic animals when they are swimming upstream and are unable to swim out of the culvert. Only measure if it is safe to access the pipe, otherwise estimate the drop and check the appropriate box. Measure or estimate the distance that water has to drop to enter the culvert (e.g. from the top of the water in the stream just above the inlet to the top of the water in the culvert at the inlet) and record the measurement (in inches).

Outlet Drop: When water drops off or cascades down from the outlet, usually into a receiving pool. This may be due to the original design/construction or subsequent erosion of material at the downstream end of crossing. Outlet drops create barriers to the upstream movement of fish and other aquatic animals that are unable to jump up over the drop. Only measure if it is safe to access the pipe, otherwise estimate the two drop characteristics. Record the measurements (in inches) and check the appropriate boxes (measured or estimated).

- a. Culvert bottom to water surface – Measure or estimate the distance from the bottom of the culvert to the water surface in the first pool large enough to provide resting habitat for fish swimming upstream.
- b. Culvert bottom to stream bed – Measure or estimate the distance from the bottom of the culvert to the bottom of the channel in the stream bed directly below the outlet.

- c. If there is an outlet drop, check “cascade” if the water tumbles over rocks, logs, or other debris; or “freefall”, if the water falls directly into the pool below. Use “freefall onto cascade” for a combination of characteristics (see illustrations below).

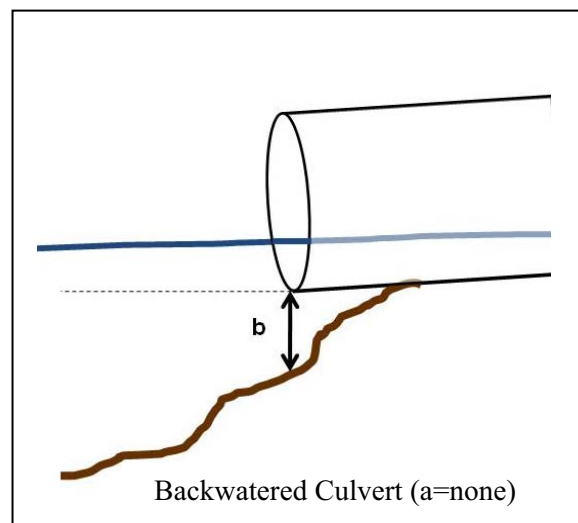
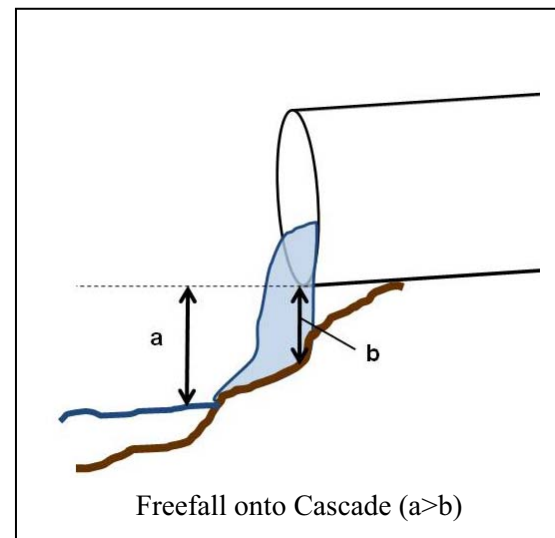
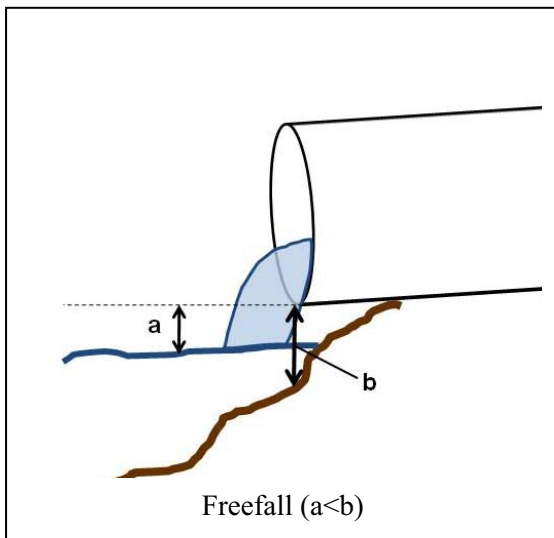
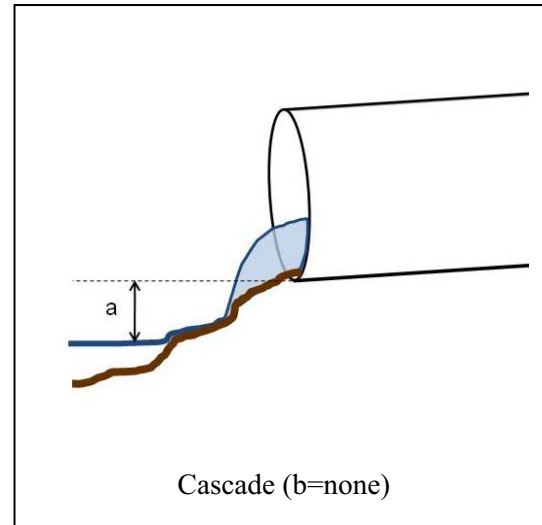
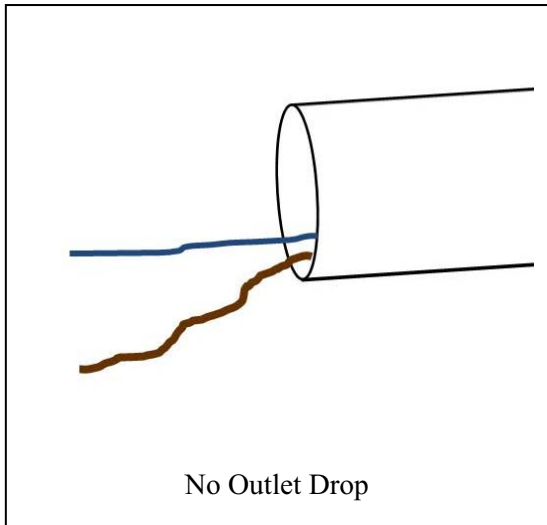



Armored Streambed at Outlet: This includes concrete aprons, plastic aprons, riprap or other structures added to the *streambed* at the crossing outlet to facilitate flow and prevent erosion. This does not include wing walls, retaining walls, or armored stream banks. Indicate on the data form whether tailwater armoring at the outlet of the crossing is “extensive”, “not extensive” or absent (“none”). Armoring is considered extensive if it covers the entire width of the channel at the outlet and extends downstream for a length equal to or greater than half the bankfull width of the natural stream.

Crossing embedded?: An embedded culvert is a culvert that is installed in such a way that the bottom of the structure is below the stream bed and there is substrate in the culvert. Indicate on the data form whether or not the culvert is embedded and the degree that the culvert is embedded.

- If the culvert is not buried and generally lacks substrate, then check “Not embedded”.
- If the culvert is partially buried and contains substrate for half or more of its length, check “Partially embedded.”
- If the culvert is buried for its entire length, check “Fully embedded”.
- If the structure has no bottom (bridge, open bottom arch, etc.) or is a ford then check “No bottom.”

Crossing substrate: Record whether the substrate in the crossing is “Inappropriate,” “Contrasting,” “Comparable” or absent (“None”).

- If the culvert is not fully embedded check “None.” If a culvert is only partially embedded then the substrate should be considered “none.”
  - Check “None (smooth)” if the structure bottom lacks corrugations or other roughened conditions
  - Check “None (rough/corrugated)” if the structure bottom is corrugated (e.g. metal or plastic pipe), contains some substrate (but not enough to be considered fully embedded) or is otherwise roughened.
- Large riprap and broken slabs of concrete are examples of substrates that are “Inappropriate” for river and stream continuity.
- Check “Contrasting” if the substrate is not wholly inappropriate, but contrasts with the substrate in the natural stream channel. For example, if the crossing’s predominant substrate is boulders and large cobble on a stream where the natural stream bottom is predominantly mud/muck.
- Check “Comparable” if the substrate in the crossing is similar to that found in the natural stream channel.

Physical barriers to fish and wildlife passage: This includes any durable structure that physically blocks fish or wildlife movement. Do not include temporary barriers such as debris or sediment accumulations that are not likely to persist for a number of years. If physical barriers exist at a crossing indicate whether the barrier effect is:

- “Severe” (essentially blocking all fish and wildlife passage),
- “Moderate” (blocking passage for some species or individuals but not others) or
- “Minor” (blocking passage for only a few species or individuals or for only a small proportion of the year) and describe them on the data form.
- Otherwise check “None.”

Crossing span: Natural streams are variable in width. In selecting the appropriate category consider the average conditions in the natural stream channel outside the influence of the crossing itself.

Bankfull is amount of water that just fills the stream channel and where additional water would result in a rapid widening of the stream or overflow into the floodplain. Indicators of bankfull width include<sup>1</sup>:

- Abrupt transition from bank to floodplain. The change from a vertical bank to a horizontal surface is the best identifier of the floodplain and bankfull stage, especially in low-gradient meandering streams.
- Top of point bars. The point bar consists of channel material deposited on the inside of meander bends. Set the top elevation of point bars as the lowest possible bankfull stage.
- Bank undercuts. Maximum heights of bank undercuts are useful indicators in steep channels lacking floodplains.
- Changes in bank material. Changes in soil particle size may indicate the operation of different processes. Changes in slope may also be associated with a change in particle size.
- Change in vegetation. Look for the low limit of perennial vegetation on the bank, or a sharp break in the density or type of vegetation.

Check the appropriate description from the list below.

Severe constriction: The crossing is half as wide, or narrower, than the bankfull width of the natural stream.

Mild constriction: The crossing is narrower than bankfull width in the natural channel upstream and downstream of the crossing but not enough to qualify as a severe constriction.

Spans bank to bank: Choose this option if the crossing spans the bankfull width of the channel, but does not include the banks of the stream.

Spans channel and banks: Choose this option if the crossing structure spans the bankfull channel width and one or more of the banks with sufficient headroom to allow dry passage for some wildlife.

Tailwater scour pool: These are pools created downstream as a result of high flows exiting the crossing. Use as a reference natural pools occurring in a portion of the stream that is outside the influence of the crossing structure and not otherwise altered. A scour pool is considered to exist when its size (a combination of length, width and depth) is larger than pools found in the natural stream. Check "Large" if the width or depth of the pool is twice that of pools in the natural stream channel or more. Otherwise, check either "Small" if a smaller pool exists or "None" if there is no scour pool.

Water depth matches stream? – To evaluate water depth use as a reference a portion of the natural stream channel that is outside the influence of the crossing structure and not otherwise altered. Depth is considered comparable if water depths in the crossing are similar to the depths upstream and downstream in the natural stream channel. Comparable means that the depth in the crossing falls within the range of depths naturally occurring in that reach of the stream and for comparable distances. For example a crossing that has water depths that are similar to those found in deeper pool sections of the stream but that extend for longer distances along the stream than do the pools

---

<sup>1</sup> Adapted from Georgia Adopt-A-Stream "Visual Stream Survey" manual. Georgia Department of Natural Resources, 2002.

would not be considered comparable. After evaluating the crossing relative to the natural stream check the most appropriate option among “Yes (comparable),” “No (deeper),” “No (shallower)” or “Dry.”

Water velocity matches stream? – To evaluate water velocity use as a reference a portion of the natural stream channel that is outside the influence of the crossing structure and not otherwise altered. Velocity is considered comparable if water velocities in the crossing are similar to the velocities in the nature stream channel upstream and downstream of the crossing. Comparable means that the velocities in the crossing fall within the range of velocities naturally occurring in that reach of the stream and for comparable distances. For example a crossing that has water velocities that are similar to those found in riffle sections of the stream but that extend for longer distances along the stream than do the riffles would not be considered comparable. After evaluating the crossing relative to the natural stream check the most appropriate option among “Yes (comparable),” “No (slower),” “No (faster)” or “Dry.”

Crossing Slope matches stream? – To evaluate crossing slope use as a reference a portion of the natural stream channel that is outside the influence of the crossing structure and not otherwise altered. Slope is considered comparable if the crossing slope is similar to the slopes found in the nature stream channel upstream and downstream of the crossing. Comparable means that the crossing slope falls within the range of slopes naturally occurring in that reach of the stream and for comparable distances. For example a crossing that has a slope that is similar to that found in short, high-gradient sections of the stream but that extend for longer distances than found in the natural stream would not be considered comparable. After evaluating the crossing relative to the natural stream check the most appropriate option among “Yes (comparable),” “No (flatter)” or “No (steeper).”

Comments – Add anything you feel may not have been included, but is important for describing the crossing.

## **CROSSING DIMENSIONS**

Upstream/Downstream Crossing Type – Choose the most appropriate choice from #1-9 or Ford that describes the type of crossing. Record crossing type separately for upstream and downstream portions of the structure. If you have a partially embedded culvert you will have a different culvert type at one end (e.g. round culvert) compared to the other (e.g. embedded round culvert) and will need to record different dimensions.

1.-Open Bottom Arch will look like a pipe culvert on the top half, but you will not see a bottom half. Instead for the bottom, it has metal footings that are sunk into concrete below the stream channel. For recording dimensions a stone arch bridge should be considered an open bottom arch.

2.-Bridge with abutments will have sides at right angles, but no bottom structure.

3.-Bridge with side slopes will have angled sides, and no bottom structure.

4.-Bridge with side slopes and abutments will have both sloping sides as well as sides at right angles to give the bridge height over the stream.

5.-Round Culvert will be a circular pipe.

6. Elliptical Culvert will have a wider, squashed look than a round pipe culvert.

7. Box Culvert will usually be made of concrete.

8. Embedded Round Culvert means that the culvert is partially buried below the stream channel so that natural sediment will flow through and you won't see the bottom of the culvert.

9. Embedded Elliptical Culvert Also known as a “pipe arch” this is an elliptical culvert where the bottom has been buried below the stream channel.

Ford is a shallow water crossing directly across the streambed, often with logs, stone, or gravel to protect or stabilize the bottom. These are rare, and are mostly found on roads that are not frequently used.

Upstream /Downstream dimensions (ft.) Provide the measurements shown in the appropriate diagram for the crossing type. **(If measurements cannot be taken, please estimate and write EST. after estimated measurement.)**

- A. Measure interior width of crossing.
- B. Measure height from underside of crossing to **water surface**. (Measure to stream bottom if there is no flow.)
- C. Measure width of actual stream channel (wetted width) through crossing structure if natural bottom exists (i.e. bridges or embedded culverts).
- D. Measure height of vertical abutments from underside of bridge to where sides start sloping.

Length of stream through crossing (ft.) Measure the crossing from inlet to outlet by walking through the structure if it is large enough and safe to do so. If walking through culvert is not possible, then hold measuring tape at inlet and let current carry it to the outlet where someone else catches it and measure the length. Another option is to estimate length by measuring distance from inlet to outlet on the road above the structure.

#### **DIMENSIONS FOR MULTIPLE CULVERT CROSSINGS**

***When inventorying multiple culverts, label left culvert 1 and go in increasing order from left to right from downstream end (outlet) looking upstream.***

Number of Culverts or Bridge Cells – How many culverts are present? Include ones that may not have any flow. How many separate channels flow beneath the bridge due to piers, footings, or debris etc.?

Upstream/ Downstream dimensions: Follow the same instructions as above. If measurements cannot be taken, please estimate and write EST. after estimated measurement. If all the culverts or bridge cells have the same dimensions and length you can check the box provided. By checking this box you don't have to enter dimensions/length data for the additional culverts/cells.

## Glossary

- **Bankfull Width** – Bankfull is amount of water that just fills the stream channel and where additional water would result in a rapid widening of the stream or overflow into the floodplain. Indicators of Bankfull width include:
- Abrupt transition from bank to floodplain. The change from a vertical bank to a horizontal surface is the best identifier of the floodplain and Bankfull stage, especially in low-gradient meandering streams.
  - Top of pointbars. The pointbar consists of channel material deposited on the inside of meander bends. Set the top elevation of pointbars as the lowest possible Bankfull stage.
  - Bank undercuts. Maximum heights of bank undercuts are useful indicators in steep channels lacking floodplains.
  - Changes in bank material. Changes in soil particle size may indicate the operation of different processes. Changes in slope may also be associated with a change in particle size.
  - Change in vegetation. Look for the low limit of perennial vegetation on the bank, or a sharp break in the density or type of vegetation.
- **Bridge** – A crossing structure typically consisting of abutments and a deck spanning the stream.
- **Culvert** – Round, elliptical or rectangular structures that are fully enclosed (contain a bottom) designed primarily for channeling water beneath a road, railroad or highway.
- **Embedded Culvert** – A culvert that is installed in such a way that the bottom of the structure is below the stream bed and there is substrate in the culvert.
- **Ford** – Modified or unmodified portions of a stream or river where vehicle drive through rather than over the streambed. Vented fords provide culverts to pass water during low flows while higher flows pass over the ford.
- **Inlet drop** – Where water level drops suddenly at an inlet, causing changes in water speed and turbulence. In addition to the higher velocities and turbulence, these jumps can be physical barriers to fish and other aquatic animals when they are swimming upstream and are unable to swim out of the culvert.
- **Open Bottom Arch** – An arched crossing structure that spans all or part of the stream bed, typically constructed on buried footings and without a bottom.
- **Open Bottom Box Culvert** – A pre-cast box culvert with no bottom that spans all or part of the stream bed. Difficult to distinguish from a bridge.
- **Openness ratio** – Equals cross-sectional area of the structure divided by crossing length when measured in meters. For a box culvert, openness = (height x width)/ length.
- **Outlet drop** – An outlet drop occurs when water drops off or cascades down from the outlet, usually into a receiving pool. This may be due to the original culvert placement or erosion of material at the downstream end of culvert. Outlet drops are barriers to fish and other aquatic animals that can't jump to get up into the culvert.

- **Physical barriers to fish and wildlife passage** – Any structure that physically blocks fish or wildlife movement as well as structures that would cause a culvert to become blocked. Beaver dams, debris jams, fences, sediment filling culvert, weirs, baffles, aprons, and gabions are examples of structures that might be or cause physical barriers. Weirs are short dams or fences in the stream that constrict water flow or fish movements. Baffles are structures within culverts that direct, constrict, or slow down water flow. Gabions are rectangular wire mesh baskets filled with rock that are used as retaining walls and erosion control structures.
- **Pipe Arch** – A pipe that has been factory deformed from a circular shape such that the width (or span) is larger than the vertical dimension (or rise), and forms a continuous circumference pipe that is not bottomless.
- **Tailwater armoring** – Concrete aprons, plastic aprons, riprap or other structures added to culvert outlets to facilitate flow and prevent erosion.
- **Tailwater scour pool** – A pool created downstream from high flows exiting the culvert. The pool is wider than the stream channel and banks are eroded.

# Field Data Form: Road-Stream Crossing Inventory

Coordinator \_\_\_\_\_ Crossing ID# \_\_\_\_\_

Stream/River: \_\_\_\_\_ Road: \_\_\_\_\_ Town: \_\_\_\_\_

Flow condition:  Unusually low  Typical low-flow  Average flow  Higher than average

### GPS Coordinates (lat/long):

Decimal degrees N \_\_\_\_\_ . \_\_\_\_\_ W \_\_\_\_\_ . \_\_\_\_\_  
OR  Degrees, minutes, seconds North: D \_\_\_\_\_ M \_\_\_\_\_ S \_\_\_\_\_  
West: D \_\_\_\_\_ M \_\_\_\_\_ S \_\_\_\_\_

Date: \_\_\_\_\_ Location: \_\_\_\_\_ Observer: \_\_\_\_\_

Photo IDs: \_\_\_\_\_

### Road/Railway Characteristics

- 1. Road surface:  Paved  Unpaved
- 2. Road type:  1-Lane road  2-Lane road  Multilane road (>2 lanes)  Divided highway  Railroad

### Crossing/Stream Characteristics (during generally low-flow conditions)

- 3. Crossing type:  Ford  Bridge  Open bottom arch  Single culvert  Multiple culverts (# of culverts) \_\_\_\_\_
- 4. Condition of crossing:  Excellent  Fair  Poor
- 5. Does the stream at the crossing support fish?  Yes  Not likely  Don't know
- 6. Is the stream flowing?  Yes  No
- 7. Structure height at low water \_\_\_\_\_ Feet  Measured  Estimated  
(from water level to the roof inside the structure)
- 8. Inlet Drop \_\_\_\_\_ Inches  Measured  Estimated
- 9. Outlet Drop
  - a. Culvert bottom to water surface \_\_\_\_\_ Inches  Measured  Estimated
  - b. Culvert bottom to stream bed \_\_\_\_\_ Inches  Measured  Estimated
  - c. With an outlet drop, check one:  Cascade  Freefall  Freefall onto cascade
- 10. Armored streambed at outlet:  Extensive  Not extensive  None
- 11. Crossing embedded?  Not embedded  Partially embedded  Fully embedded  No Bottom
- 12. Crossing substrate:  None (smooth)  None (rough/corrugated)  Inappropriate  Contrasting  Comparable
- 13. Physical Barriers to fish and wildlife passage:  Severe  Moderate  Minor  None

Describe any barriers: \_\_\_\_\_

**For the following questions use as a reference a portion of the natural stream channel that is outside the influence of the crossing structure and not otherwise altered.**

- 14. Crossing span:  Severe constriction  Mild constriction  Spans bank to bank  Spans channel & banks
- 15. Scour pool:  None  Small (wider or deeper than natural stream)  Large (width or depth 2X natural stream)
- 16. Water depth matches stream?  Yes (comparable)  No (deeper)  No (shallower)  Dry
- 17. Water velocity matches stream?  Yes (comparable)  No (slower)  No (faster)  Dry
- 18. Crossing Slope matches stream?  Yes (comparable)  No (flatter)  No (steeper)
- 19. Comments \_\_\_\_\_

**CROSSING DIMENSIONS**

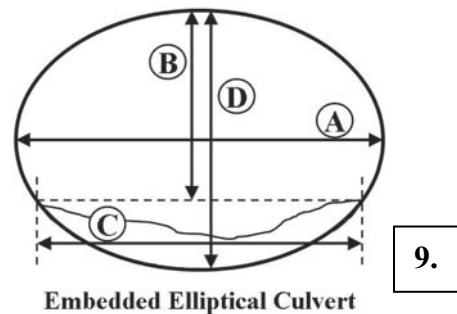
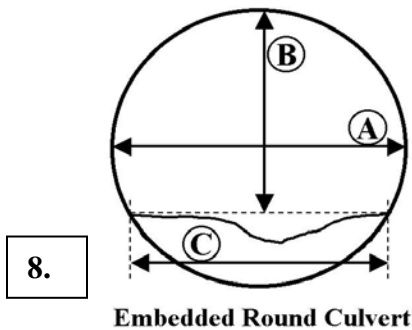
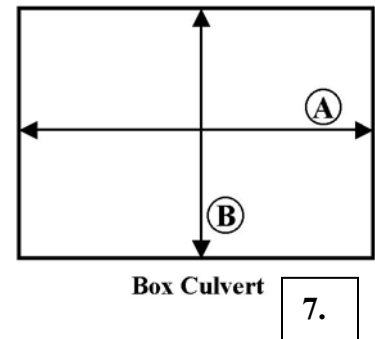
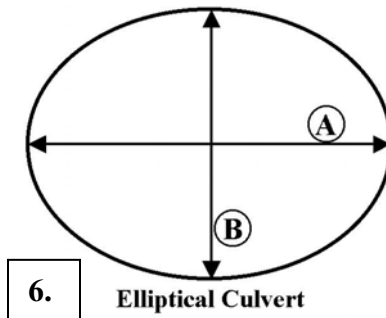
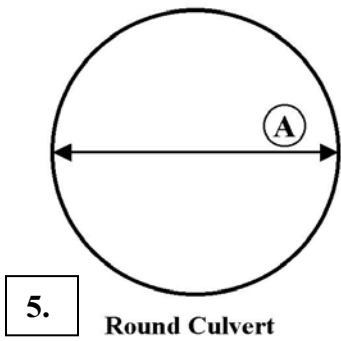
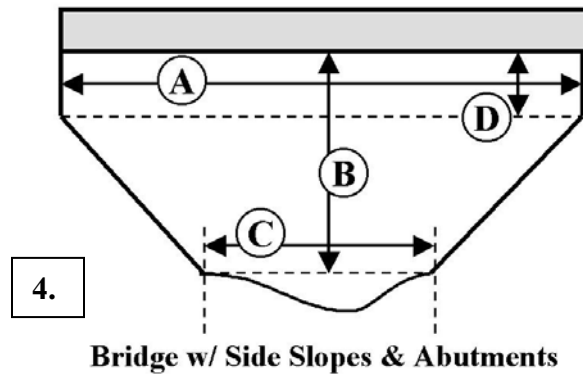
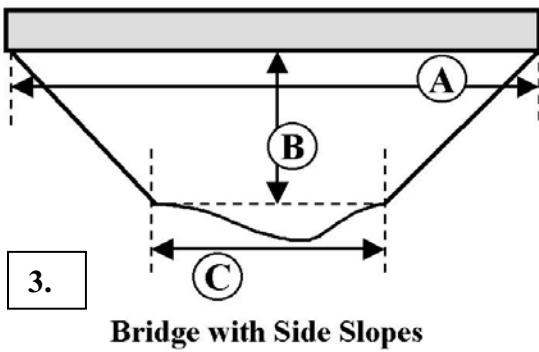
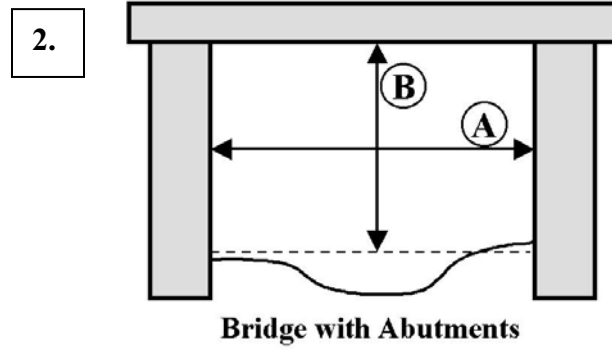
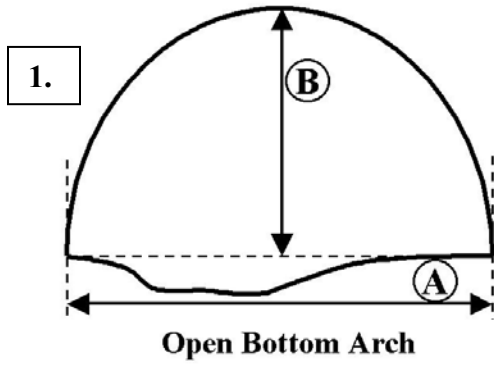

Upstream Crossing Type (from above):  1.  2.  3.  4.  5.  6.  7.  8.  9.  Ford

Upstream Dimensions (ft.): A) \_\_\_\_\_ B) \_\_\_\_\_ C) \_\_\_\_\_ D) \_\_\_\_\_

Downstream Crossing Type (from above):  1.  2.  3.  4.  5.  6.  7.  8.  9.  Ford

Downstream Dimensions (ft.): A) \_\_\_\_\_ B) \_\_\_\_\_ C) \_\_\_\_\_ D) \_\_\_\_\_

Length of stream through crossing (ft.): \_\_\_\_\_



## DIMENSIONS WORKSHEET FOR MULTIPLE CULVERT CROSSINGS

Crossing ID# \_\_\_\_\_

**Note:** When inventorying multiple culverts, label left culvert 1 and go in increasing order from left to right from downstream end (outlet) looking upstream.

**Number of Culverts or Bridge Cells** \_\_\_\_\_

**Check here if all culverts or bridge cells have the same dimensions and lengths**

**Culvert or Bridge Cell 2 of** \_\_\_\_\_

**Upstream Crossing Type:**       1.    2.    3.    4.    5.    6.    7.    8.    9.    Ford

**Upstream Dimensions (ft.):**    A) \_\_\_\_\_    B) \_\_\_\_\_    C) \_\_\_\_\_    D) \_\_\_\_\_

**Downstream Crossing Type:**    1.    2.    3.    4.    5.    6.    7.    8.    9.    Ford

**Downstream Dimensions (ft.):** A) \_\_\_\_\_    B) \_\_\_\_\_    C) \_\_\_\_\_    D) \_\_\_\_\_

**Length of stream through crossing (ft.):** \_\_\_\_\_

**Culvert or Bridge Cell 3 of** \_\_\_\_\_

**Upstream Crossing Type:**       1.    2.    3.    4.    5.    6.    7.    8.    9.    Ford

**Upstream Dimensions (ft.):**    A) \_\_\_\_\_    B) \_\_\_\_\_    C) \_\_\_\_\_    D) \_\_\_\_\_

**Downstream Crossing Type:**    1.    2.    3.    4.    5.    6.    7.    8.    9.    Ford

**Downstream Dimensions (ft.):** A) \_\_\_\_\_    B) \_\_\_\_\_    C) \_\_\_\_\_    D) \_\_\_\_\_

**Length of stream through crossing (ft.):** \_\_\_\_\_

**Culvert or Bridge Cell 4 of** \_\_\_\_\_

**Upstream Crossing Type:**       1.    2.    3.    4.    5.    6.    7.    8.    9.    Ford

**Upstream Dimensions (ft.):**    A) \_\_\_\_\_    B) \_\_\_\_\_    C) \_\_\_\_\_    D) \_\_\_\_\_

**Downstream Crossing Type:**    1.    2.    3.    4.    5.    6.    7.    8.    9.    Ford

**Downstream Dimensions (ft.):** A) \_\_\_\_\_    B) \_\_\_\_\_    C) \_\_\_\_\_    D) \_\_\_\_\_

**Length of stream through crossing (ft.):** \_\_\_\_\_

**Culvert or Bridge Cell 5 of** \_\_\_\_\_

**Upstream Crossing Type:**       1.    2.    3.    4.    5.    6.    7.    8.    9.    Ford

**Upstream Dimensions (ft.):**    A) \_\_\_\_\_    B) \_\_\_\_\_    C) \_\_\_\_\_    D) \_\_\_\_\_

**Downstream Crossing Type:**    1.    2.    3.    4.    5.    6.    7.    8.    9.    Ford

**Downstream Dimensions (ft.):** A) \_\_\_\_\_    B) \_\_\_\_\_    C) \_\_\_\_\_    D) \_\_\_\_\_

**Length of stream through crossing (ft.):** \_\_\_\_\_

[Intentionally Left Blank]

## **Appendix C**

### **US Army Corps of Engineers Massachusetts General Permit**



**DEPARTMENT OF THE ARMY  
GENERAL PERMIT  
COMMONWEALTH OF MASSACHUSETTS**

The New England District of the U.S. Army Corps of Engineers (Corps) hereby issues this General Permit (GP) for activities in waters of the United States (U.S.) that have minimal individual and cumulative adverse effects on the aquatic environment within the Commonwealth of Massachusetts.

**I. GENERAL CRITERIA:**

In order for activities to qualify for this GP, they must meet the GP's terms and eligibility criteria (Pages 1 - 4), general conditions (GC) (Pages 5 - 14), and Appendix A - Definition of Categories, qualify for authorization under this GP in either Category 1 or Category 2.

Under this GP, projects may qualify for the following:

- Category 1: No application required. (Submittal of the Category 1 Form at Appendix C is required.).
- Category 2: Application required.

If you determine that your project is eligible for Category 1 no application to the Corps is required. However, you must submit the Category 1 Form (Appendix C) to the Corps.

If your project is ineligible for Category 1, it may qualify for Category 2 or an Individual Permit and you must submit an application (see Page 3). The thresholds for categories 1 and 2 are defined in Appendix A. This GP does not affect the Corps Individual Permit review process or activities exempt from Corps regulation.

**II. ACTIVITIES COVERED:**

- Work and structures that are located in, under or over any navigable water of the United States (U.S.)<sup>1</sup>; that affect the course, location, condition, or capacity of such waters; or the excavating from or depositing of material in such waters. (Regulated by the Corps under Section 10 of the Rivers and Harbors Act of 1899);
- The discharge of dredged or fill material into waters of the U.S.<sup>1</sup>, which is regulated by the Corps under Section 404 of the Clean Water Act (CWA).<sup>2</sup>
- The transportation of dredged material for the purpose of disposal in the ocean (regulated by the Corps under Section 103 of the Marine Protection, Research and Sanctuaries Act).

---

<sup>1</sup> Defined at 33 CFR 328

<sup>2</sup> When there is a regulated discharge of dredged or fill material into waters of the U.S., the Corps will also consider secondary impacts, which are defined at Appendix A, Endnote/Definition 2.

### III. APPROVAL PROCESS

#### 1. State and Local Approvals

Applicants are responsible for applying for and obtaining any of the required State or local approvals (see GC 1, Page 5). Federal and state jurisdictions may differ in some instances. State permits may be required for specific projects regardless of the general permit category.

In order for authorizations under this GP to be valid, when any of the following state approvals or statutorily-required reviews is also required, the approvals must be obtained prior to the commencement of work in Corps jurisdiction.

- **Final Order of Conditions** under the Massachusetts Wetlands Protection Act (WPA) (MGL c. 131 Section 40) must be obtained for activities subject to jurisdiction as defined in 310 CMR 10.02.
- **Waterways license** or permit under MGL c. 91, from the Massachusetts Department of Environmental Protection (MassDEP) must be obtained for activities subject to its jurisdiction, defined in 310 CMR 9.05.
- **Water Quality Certification (WQC)** is required for work in Corps jurisdiction involving a discharge of dredged or fill materials to waters of the U.S., including wetlands. Some projects require an individual WQC issued by the MassDEP under Section 401 of the Clean Water Act and 314 CMR 9.00, before work can proceed (see Appendix B for 401 WQC requirements).
- **Coastal Zone Management (CZM):** Any project that qualifies for Category 1 of this GP has been determined to be consistent with the Massachusetts CZM plan and does not require any additional CZM review. For Category 2 work in or affecting the coastal zone, the Corps will coordinate review with the Office of CZM and then notify applicants if an Individual CZM concurrence is required.

#### 2. Corps Authorizations

The two GP review categories are listed below.

##### a. CATEGORY 1 (No application)

##### Eligibility Criteria

Activities in Massachusetts that:

- are subject to Corps jurisdiction (see GC 2, Page 5),
- meet the terms of this GP (Pages 1 - 4),
- meet all GCs of this GP (Pages 5 – 14), and
- meet the definition of Category 1 in Appendix A - Definition of Categories,

may proceed without application to the Corps provided the Category 1 Form (Appendix C) is submitted to the Corps before starting the work authorized by this GP.

Project proponents seeking Category 1 authorizations must comply with this GP's general conditions (starting on Page 5) and other federal laws such as the National Historic Preservation Act, the Endangered Species Act (ESA), and the Wild and Scenic Rivers Act. Therefore, consultation with the Corps and/or outside experts such as the State Historical Preservation Officer (SHPO)/ Massachusetts Historical Commission (MHC), the Massachusetts Board of Underwater Archaeological Resources (BUAR) and the four Native American tribes is required to ensure compliance with General Condition 7 (e.g., when there is a high likelihood of the presence of resources of concern). See Appendix E for contact information and geographic areas of concern.

Work that is not subject to the Commonwealth's Wetland Protection Act but is subject to Corps jurisdiction, is eligible for Corps Category 1 authorization under this GP. Although an Order of Conditions is not required if the work is not subject to the WPA, this GP's review thresholds and requirements concerning WQC and CZM consistency apply. Such projects could include activities that are exempt from the WPA or activities in federal wetlands that are not included in the WPA.

## **b. CATEGORY 2 (Reporting – Requiring Review)**

### **Eligibility Criteria**

Activities in Massachusetts that:

- are subject to Corps jurisdiction, (see GC 2, Page 5),
- meet the terms of this GP (Pages 1 - 4),
- meet all GCs of this GP (Pages 5 – 14), and
- meet the definition of Category 2 in Appendix A - Definition of Categories

require written approval from the Corps. The Corps will coordinate review of all Category 2 activities with federal and state agencies, as appropriate, to ensure that the GP results in no more than a minimal impact to the aquatic environment. To be eligible and subsequently authorized, an activity must result in no more than minimal impacts to the aquatic environment as determined by the Corps in coordination with the interagency review team and the criteria listed above. This may require project modifications involving avoidance, minimization, or compensatory mitigation for unavoidable impacts to ensure the net effects of a project are minimal.

## **3. Applying for a Permit**

All applicants for Category 2 projects must:

- a. Apply as appropriate to the:
  - i. MassDEP or conservation commission for authorization under Section 401 or Chapter 91.
  - ii. Corps (and MassDEP or conservation commission as appropriate) for emergency situations. Proponents are encouraged to call the Corps (see Appendix E) promptly.
  - iii. Corps for projects not requiring MassDEP review using the Corps application form<sup>1</sup>.

For projects requiring both MassDEP and Corps review, the Corps will obtain copies of applications from the DEP regional offices at our interagency meetings. Attaching the Information Required Checklist (Appendix D) with the required information to all applications will help ensure the application is complete. Applicants have the option of sending duplicate copies of applications directly to the Corps.

b. Submit the SHPO/MHC's "Project Notification Form" (follow "Guidance for Completing MHC's Project Notification Form")<sup>1</sup>, a USGS locus map with the project boundaries clearly located, and scaled existing and proposed project plans to the SHPO/MHC, BUAR, and the four Native American tribes when applicable (see Appendix E, pages 1 and 2 for contact information and geographic areas of interest) to be reviewed for the presence of historic, archaeological, or tribal resources in the permit area that the proposed work may affect. All applications to the Corps or DEP shall confirm this has been done, when applicable, by submitting a copy of the applicant's cover letter to the SHPO/MHC, BUAR and the tribes, or a copy of their response letters.

---

<sup>1</sup> See Appendix F for form information.

## 4. Review Procedures

The Corps will coordinate review of all Category 2 activities with federal and state agencies, as appropriate, to ensure that the work will result in no more than a minimal impact to the aquatic environment. Applicants are responsible for applying for the appropriate state and local approvals listed on Page 2.

**Massachusetts Office of Coastal Zone Management (CZM) Screening Procedures:** The CZM has issued consistency for projects meeting Category 1 of the GP and no further coordination with CZM is required for those projects. The Corps will coordinate Category 2 projects that involve work in or affecting the coastal zone with CZM. The CZM will make a determination within 10 business days of coordination that (1) CZM consistency may be waived; (2) CZM consistency may be waived provided CZM and the Corps agree to special conditions in the Corps authorization to protect the land or water uses or natural resources of the coastal zone; or (3) an individual CZM consistency concurrence will be required for the project. If CZM waives/issues consistency [(1) or (2) above], the Corps will attempt to include that determination in the Corps authorization letter. If CZM requires an individual CZM consistency concurrence [(3) above], the Corps may issue a conditional letter, which will notify the applicant that the federal authorization is not valid until CZM consistency concurrence is issued or waived by CZM.

**Emergency Procedures:** 33 CFR 325.2(e)4 states that an “emergency” is a situation which would result in an unacceptable hazard to life, a significant loss of property, or an immediate, unforeseen, and significant economic hardship if corrective action requiring a permit is not undertaken within a time period less than the normal time needed to process the application under standard procedures.” The Corps will work with all applicable agencies to expedite authorization in emergency situations.

**Individual Permit Procedures:** Proponents of work that is defined in the Individual Permit category of Appendix A - Definition of Categories, or that does not meet the terms and general conditions of this GP, should submit an application and the appropriate application materials (including the Corps application form) to the Corps (see 33 CFR 325.1) at the earliest possible date in order to expedite the Individual Permit review process. General information and application forms can be obtained at our website or by calling us (see Appendix E). Individual WQC and CZM consistency concurrence are required when applicable from the Commonwealth of Massachusetts before Corps permit issuance. The Corps encourages applicants to concurrently apply for a Corps Individual Permit and state permits.

## 5. Approval Process

Applicants for Category 2 activities may not proceed with work in Corps jurisdiction until written authorization is received from the Corps. Applicants are responsible for obtaining all applicable approvals listed on Page 2 from the appropriate state and local agencies before commencing work in Corps jurisdiction.



#### **IV. GP GENERAL CONDITIONS:**

The following general conditions apply to all Category 1 and Category 2 activities authorized under this GP unless otherwise specified.

**1. Other Permits.** Authorization under this GP does not obviate the need to obtain other federal, state, or local authorizations required by law.

**2. Federal Jurisdictional Boundaries.** Applicability of this GP shall be evaluated with reference to federal jurisdictional boundaries. Applicants are responsible for ensuring that the boundaries used satisfy the federal criteria defined at 33 CFR 328-329. Wetland boundaries shall be delineated in accordance with the January 1987 Corps of Engineers Wetlands Delineation Manual and applicable regional supplements. See Appendix F.

#### **3. Minimal Direct, Secondary and Cumulative Impacts.**

(a) Projects authorized by this GP shall have no more than minimal direct, secondary and cumulative adverse environmental impacts. Applicants should provide information on secondary and cumulative impacts (see Appendix D). Mitigation may be required to offset unavoidable impacts (see GC 15) and to ensure that they are no more than minimal.

(b) Secondary impacts to waterway and/or wetland areas, (e.g., areas drained, flooded, cleared, excavated or fragmented) shall be added to the total fill area when determining whether the project qualifies for Category 1 or 2. Direct, secondary and cumulative impacts are defined at Appendix A, Endnote 2.

- Unless specifically authorized, no work shall drain a water of the U.S. by providing a conduit for water on or below the surface.
- Site clearing, grading and construction activities in the upland habitat surrounding vernal pools (“vernal pool management areas”) are secondary impacts. See GC 15.

**4. Discretionary Authority.** Notwithstanding compliance with the terms and conditions of this permit, the Corps retains discretionary authority to require an Individual Permit review based on concerns for the aquatic environment or for any other factor of the public interest [33 CFR 320.4(a)]. This authority is invoked on a case-by-case basis whenever the Corps determines that the potential consequences of the proposal warrant Individual Permit review based on the concerns stated above. This authority may be invoked for projects with cumulative environmental impacts that are more than minimal or if there is a special resource or concern associated with a particular project that is not already covered by the remaining conditions of the GP that warrants greater review. Whenever the Corps notifies an applicant that an Individual Permit is required, the project is not authorized under this GP and no work may be conducted until an Individual Permit is obtained or until the Corps notifies the applicant that further review has demonstrated that the work may proceed under this GP.

#### **5. Single and Complete Projects.**

(a) This GP shall not be used to piecemeal work and shall be applied to single and complete projects<sup>1</sup>. When determining the review category in Appendix A (Category 1, 2) for a single and complete project, proponents must include any permanent historic fill placed since August 1993 that is associated with that project and all currently proposed temporary and permanent impact areas.

(b) A single and complete project must have independent utility<sup>1</sup>.

---

<sup>1</sup> Single and Complete Project and Independent Utility are defined at Appendix F.

(c) Unless the Corps determines the activity has independent utility:

i. This GP shall not be used for any activity that is part of an overall project for which an Individual Permit is required,

ii. All components of a single project and/or all planned phases of a multi-phased project shall be treated together as constituting one single and complete project.

(d) For linear projects, such as power lines or pipelines with multiple crossings, a “single and complete project” is all crossings of a single water of the U.S. (i.e., single waterbody) at a specific location. For linear projects crossing a single waterbody several times at separate and distant locations, each crossing is considered a single and complete project. However, individual channels in a braided stream or river, or individual arms of a large, irregularly-shaped wetland or lake, etc., are not separate waterbodies, and crossings of such features cannot be considered separately. If any crossing requires a Category 2 activity, then the entire linear project shall be reviewed as one project under Category 2.

**6. Permit On-Site.** For Category 2 projects, the permittee shall ensure that a copy of this GP and the accompanying authorization letter are at the work site (and the project office) authorized by this GP whenever work is being performed, and that all personnel with operation control of the site ensure that all appropriate personnel performing work are fully aware of its terms and conditions. The entire permit authorization shall be made a part of any and all contracts and sub-contracts for work that affects areas of Corps jurisdiction at the site of the work authorized by this GP. This shall be achieved by including the entire permit authorization in the specifications for work. The term “entire permit authorization” means this GP and the authorization letter (including its drawings, plans, appendices and other attachments) and also includes permit modifications. If the authorization letter is issued after the construction specifications, but before receipt of bids or quotes, the entire permit authorization shall be included as an addendum to the specifications. If the authorization letter is issued after receipt of bids or quotes, the entire permit authorization shall be included in the contract or sub-contract. Although the permittee may assign various aspects of the work to different contractors or sub-contractors, all contractors and sub-contractors shall be obligated by contract to comply with all environmental protection provisions contained within the entire GP authorization, and no contract or sub-contract shall require or allow unauthorized work in areas of Corps jurisdiction.

**7. Historic Properties.** Any activity authorized by this GP shall comply with Section 106 of the National Historic Preservation Act. Information on the location and existence of historic resources can be obtained from the MHC/SHPO, BUAR, the National Register of Historic Places, and the four Native American tribes listed in Appendix E, which contains contact information and geographic areas of interest for each tribe and the BUAR. Project proponents shall apply to the Corps or DEP (as required on Page 3) for all projects that would otherwise qualify for Category 1 if there is the potential for an effect on a historic property within the permit area or any known historic property that may occur outside the permit area. Historic properties include those that are eligible for inclusion, but not necessarily listed on the National Register. If the permittee, during construction of work authorized herein, encounters a previously unidentified archaeological or other cultural resource within the area subject to Corps jurisdiction that might be eligible for listing in the National Register of Historic Places, he/she shall stop work and immediately notify the Corps (see Appendix E for contact information).

**8. National Lands.** Any of the following work is not eligible as a Category 1 project:

(a) Activities that impinge upon the value of any National Wildlife Refuge, National Forest, National Marine Sanctuary (e.g., Stellwagen Bank) or any area administered by the National Park Service (e.g., Cape Cod National Seashore), U.S. Fish and Wildlife Service (USFWS) or U.S. Forest Service.

(b) Work on Corps properties and Corps-controlled easements (Appendix A, Endnote 8).

(c) Any proposed temporary or permanent modification or use of a federal project (including but not limited to a levee, dike, floodwall, channel, sea wall, bulkhead, jetty, wharf, pier, or other work built by the United States), which would obstruct or impair the usefulness of the federal project in any manner, and/or would involve changes to the authorized federal project's scope, purpose, and/or functioning that go beyond minor modifications required for normal operation and maintenance is not eligible for Category 1 and requires review and approval by the Corps pursuant to 33 USC 408.

**9. Wild and Scenic Rivers.** Any activity that occurs in the designated main stem of, within 0.25 miles up or downstream of the designated main stem of, or in tributaries within 0.25 miles of the designated main stem of a National Wild and Scenic River, or that has the potential to alter flows within a river within the National Wild and Scenic River System is not eligible for Category 1, regardless of the size of the impacts. This condition applies to both designated Wild and Scenic Rivers and rivers officially designated by Congress as study rivers for possible inclusion while such rivers are in official study status. See Appendix G for a list of rivers and procedures.

**10. Federal Endangered Species.**

(a) No activity may be authorized under this GP (Category 1 or 2) which would:

- i. Be "likely to adversely affect" a threatened or endangered species, a proposed species, designated or proposed critical habitat (all herein referred to as "listed species or habitat") as identified under the federal Endangered Species Act (ESA),
- ii. Result in a "take" of any federally-listed threatened or endangered species of fish or wildlife, or
- iii. Result in any other violation of Section 9 of the ESA protecting threatened or endangered species of plants.

(b) No activity may be authorized under Category 1 if a listed species or critical habitat is present in the action area. Project proponents must check the USFWS and National Marine Fisheries Service (NMFS) websites provided at Appendix F.

(c) Proponents must submit an application if any of the activities in (a) or (b) may occur and provide information on federally-listed species or habitat (see Appendix F) to allow the Corps to conduct any required consultation under Section 7 of the ESA.

**11. Essential Fish Habitat.** Any work in streams in the Connecticut and Merrimack River watersheds that are stocked with Atlantic salmon (see Appendix H) may be authorized under Category 1 of this GP provided the work<sup>1</sup> will NOT be conducted during the time of year restrictions stated in the Massachusetts Division of Marine Fisheries (MA DMF) document specified in GC 24(b) and Appendix F. This is to protect upstream adult migration, downstream smolt emigration and fall migration. Category 2 authorization letters from the Corps may require permittees to follow any NMFS conservation recommendations.

**12. Federal Navigation Project.** Any structure or work that extends closer to the horizontal limits of any Corps Federal Navigation Project (see Appendix I) than a distance of three times the project's authorized depth shall be subject to removal at the owner's expense prior to any future Corps dredging or the performance of periodic hydrographic surveys.

**13. Navigation.**

(a) There shall be no unreasonable interference with navigation by the existence or use of the activity authorized herein, and no attempt shall be made by the permittee to prevent the full and free use by the

---

<sup>1</sup> Exploratory drilling and borings for bridges are not subject to time of year restrictions.

public of all navigable waters at or adjacent to the activity authorized herein.

(b) The permittee understands and agrees that, if future U.S. operations require the removal, relocation, or other alteration of the structure or work herein authorized, or if, in the opinion of the Secretary of the Army or his authorized representative, said structure or work shall cause unreasonable obstruction to the free navigation of the navigable waters, the permittee will be required, upon due notice from the Corps, to remove, relocate, or alter the structural work or obstructions caused thereby, without expense to the U.S. No claim shall be made against the U.S. on account of any such removal or alteration.

**14. Federal Liability.** In issuing this permit, the Federal Government does not assume any liability for the following: (a) damages to the permitted project or uses thereof as a result of other permitted or unpermitted activities or from natural causes; (b) damages to the permitted project or uses thereof as a result of current or future activities undertaken by or on behalf of the U.S. in the public interest; (c) damages to persons, property, or to other permitted or unpermitted activities or structures caused by the activity authorized by this permit; (d) design or construction deficiencies associated with the permitted work; (e) damage claims associated with any future modification, suspension, or revocation of this permit.

**15. Avoidance, Minimization and Compensatory Mitigation.**

(a) Discharges of dredged or fill material into waters of the U.S., including wetlands, shall be avoided and minimized to the maximum extent practicable. Compensatory mitigation of unavoidable direct and indirect impacts may be required on a case-by-case basis (see Appendix F).

(b) For authorizations under this GP, the project proponent must minimize upland impacts in the surrounding “vernal pool management areas” for all VPs on, and known VPs surrounding, the project site, to the greatest extent practicable. See GC 3, page 1 of Appendix A for thresholds, Endnote 5 of Appendix A for definitions, and Appendix F for impact minimization.

**16. Heavy Equipment in Wetlands.** Operating heavy equipment other than fixed equipment (drill rigs, fixed cranes, etc.) within wetlands shall be minimized, and such equipment shall not be stored, maintained or repaired in wetlands, to the maximum extent practicable. Where construction requires heavy equipment operation in wetlands, the equipment shall either have low ground pressure (typically <3 psi), or it shall be placed on swamp/construction/timber mats (herein referred to as “construction mats” and defined at Appendix A, Endnote 3) that are adequate to support the equipment in such a way as to minimize disturbance of wetland soil and vegetation. Construction mats are to be placed in the wetland from the upland or from equipment positioned on swamp mats if working within a wetland. Dragging construction mats into position is prohibited. Other support structures that are capable of safely supporting equipment may be used with written Corps authorization. Similarly, the permittee may request written authorization from the Corps to waive use of mats during frozen or dry conditions (see GC 17 below). An adequate supply of spill containment equipment shall be maintained on site.

**17. Temporary Fill.**

Temporary fill that qualifies for Cat 1 (e.g., less than 5,000 square feet of combined temporary and permanent fill associated with the single and complete project), or is authorized in writing under Cat 2, shall adhere to the following:

(a) All temporary fill shall be stabilized to prevent its eroding into portions of waters of the U.S., including wetlands, where it is not authorized.

(b) Unconfined temporary fill authorized for discharge into waters of the U.S., including wetlands, shall consist of material that minimizes impacts to water quality (e.g. sandbags, clean gravel and/or stone).

(c) Temporary fill authorized for discharge into wetlands should be placed on geotextile fabric or other material (e.g., straw) laid on the pre-construction wetland grade where practicable to minimize impacts.

- (d) Temporary fill shall be removed as soon as it is no longer needed, disposed of at an upland site, and suitably contained to prevent its subsequent erosion into waters of the U.S., including wetlands. To qualify for Category 1, temporary fill placed during the:
- i. growing season must be removed before the beginning of the next growing season.
  - ii. non-growing season may remain throughout the following growing season, but must be removed before the beginning of the next growing season.
- (e) Waters of the U.S., including wetlands, where temporary fill was discharged shall be restored (see GC 18).
- (f) Appropriate measures must be taken to maintain normal downstream flows and minimize flooding to the maximum extent practicable, when temporary structures, work, and discharges, including cofferdams, are necessary for construction activities, access fills, or dewatering of construction sites. Temporary fills must be placed in a manner that will not be eroded by expected high flows (GC 19-21).
- (g) Construction mats and corduroy roads (see GC 16) are considered as temporary fill when they are removed immediately upon work completion. The areas must be restored (see GC 18).

### **18. Work Site Restoration.**

- (a) Wetland areas where permanent disturbance is not authorized shall be restored to their original condition and elevation, which under no circumstances shall be higher than the pre-construction elevation. Original condition means careful protection and/or removal of existing soil and vegetation, and replacement back to the original location such that the original soil layering and vegetation schemes are approximately the same, unless otherwise authorized.
- (b) Upon completion of construction, all disturbed wetland areas (the disturbance of these areas must be authorized) shall be properly stabilized. Any seed mix shall contain only plant species native to New England and shall not contain any species listed in the “Invasive and Other Unacceptable Plant Species” Appendix in the “New England District Compensatory Mitigation Guidance” (see Appendix F). This list may be updated periodically.
- (c) In areas of authorized temporary disturbance, if trees are cut they shall be cut at ground level and not uprooted in order to prevent disruption to the wetland soil structure and to allow stump sprouts to revegetate the work area, unless otherwise authorized.

### **19. Sedimentation and Erosion Control.**

- (a) Adequate sedimentation and erosion control management measures, practices and devices, such as phased construction, vegetated filter strips, geotextile silt fences, hay bales or other devices, shall be installed and properly maintained to reduce erosion and retain sediment on-site during and after construction. They shall be capable of preventing erosion, of collecting sediment, suspended and floating materials, and of filtering fine sediment.
- (b) These temporary devices shall be removed upon completion of work and the disturbed areas shall be stabilized. The sediment collected by these devices shall be removed and placed at an upland location, in a manner that will prevent its later erosion into a waterway or wetland.
- (c) All exposed soil and other fills shall be permanently stabilized at the earliest practicable date (GC 18).

### **20. Bank Stabilization.**

- (a) Projects involving construction or reconstruction/maintenance of bank stabilization structures within Corps jurisdiction must be designed to minimize environmental effects, effects to neighboring properties, scour, etc. to the maximum extent practicable.
- (b) Project proponents must stabilize the bank considering this sequential minimization process: avoidance of aquatic resource impacts, diversion of overland flow, vegetative stabilization, stone-sloped surfaces, and walls/bulkheads. Vertical walls/bulkheads shall only be used in situations where reflected wave energy can be tolerated. Refer to Appendix F.

(c) Inland Water bank stabilization activities necessary for erosion prevention must meet all of the following criteria to qualify for Category 1: (i) No material is placed in excess of the minimum needed for erosion protection; (ii) The activity is no more than 100 feet in length along the bank; (iii) The activity will not exceed an average of one cubic yard per running foot placed along the bank below the plane of the ordinary high water mark; (iv) No structures angled steeper than 3H:1V and only rough-faced stone or fiber roll revetments allowed. (v) The activity does not involve discharges of dredged or fill material into special aquatic sites; (vi) No material is of the type, or is placed in any location, or in any manner, to impair surface water flow into or out of any water of the United States; (vii) No material is placed in a manner that will be eroded by normal or expected high flows (properly anchored trees and treetops may be used in low energy areas); and, (viii) The activity is not a stream channelization activity.

## **21. Stream Crossings and Work.**

(a) All temporary and permanent crossings<sup>1</sup> of rivers, streams, brooks, etc. (hereon referred to as “streams”) shall be suitably culverted, bridged, or otherwise designed to i) withstand and prevent the restriction of high flows, and ii) not obstruct the movement of or not substantially disrupt the necessary life-cycle movements of those species of aquatic life indigenous to the waterbody, including those species that normally migrate through the area, beyond the actual duration of construction unless the activity’s primary purpose is to impound water.

(b) Any work that temporarily or permanently impacts upstream or downstream flood conditions or permanently impacts wetlands must be reviewed under Cat. 2. The “Massachusetts Dam Removal and the Wetland Regulations” may be used as a reference (see Appendix F).

[Note: (c)-(l) below only apply to Inland Waters and Wetlands (see Appendix A, Page 1 for definition).]

(c) For new stream crossings to qualify for Category 1:

i. These shall be designed and constructed<sup>2</sup> to conform to the General Standards contained in the version of the “[Massachusetts River and Stream Crossing Standards](#)” on our website (see Appendix F).

ii. These shall be at least 5-feet wide at ground level to ensure that General Standard 3 is met for small streams.

iii. Spans<sup>3</sup> are required to avoid or cause minimal disruption to the streambed. Footings and abutments shall be landward of 1.2 times bankfull width (see General Standard 3 in (c) above). To the greatest extent practicable, work in the stream shall be minimized, and design and construction shall allow the streambed’s natural structure and integrity to remain intact. Any fill or excavation of the streambed below bankfull width other than footings, support pilings, and work specified in 21(h), 21(i), 21(l)ii and 21(l)iii, requires Category 2 review and, unless demonstrated otherwise, stream simulation as necessary to restore or establish substrate and banks in the span structure and work area to match the characteristics of the substrate and banks in the natural stream channel.<sup>2</sup>

(d) For replacement stream crossings:

i. These should be designed and constructed<sup>2</sup> to conform to the General Standards contained in the version of the “Massachusetts River and Stream Crossing Standards” on our website (see Appendix F). This is recommended to ensure compliance with GC 21(a) and GC 21(b) above.

ii. Compliance with General Standards 2 and 4 is required to qualify for Category 1.

iii. Replacement crossings on the following high-quality stream segments are not eligible for Category 1: NHESP Living Water Cores, NHESP BioMap cores, ACECs, Anadromous Fish Runs, and Cold Water Fisheries. These are shown at:

[www.streamcontinuity.org/assessing\\_crossing\\_structures/prioritizing\\_streams.htm](http://www.streamcontinuity.org/assessing_crossing_structures/prioritizing_streams.htm)

<sup>1</sup> This GP does not apply to constructed drainage systems designed primarily for the conveyance of storm water or irrigation.

<sup>2</sup> See Appendix F for design and construction methodology.

<sup>3</sup> For purposes of this GP, spans are bridges, 3-sided box culverts, open-bottom culverts or arches that span the stream with footings landward of bankfull width.

- (e) Culvert extensions do not qualify for Category 1 and must be reviewed by the Corps.
- (f) For new stream crossings not eligible for Category 1, and for replacement crossings, applicants should use the least intrusive and environmentally damaging method to construct new and replacement stream crossings following this sequential minimization process: 1) Spans with no stream impacts, 2) Spans with stream impacts, and 3) Embedded culverts with stream simulation or low-slope design.
- (g) The permittee shall maintain the work authorized herein in good condition and in conformance with the terms and general conditions of this permit to facilitate aquatic life passage as stated in GC 21a. Culverts that develop “hanging” inlets or outlets, result in bed washout, or a stream that doesn’t match the characteristics of the substrate in the natural stream channel such as mobility, slope, stability, confinement will require maintenance or repair to comply with this GC.
- (h) Paragraphs (b) - (g) above do not apply to:
- i. Temporary spans<sup>3</sup>. Temporary spans shall be removed within 180 days.
  - ii. Temporary stream crossings that aren’t spans (typically culverts). To qualify for Category 1, these must be designed in accordance with 1-6 below. Category 2 projects should follow 2-6 below:
    1. Installed outside of the time of year (TOY) restrictions specified in GC 21(m) below and must be removed before the beginning of the TOY restriction of that same season. Those that will remain into the TOY restriction will require Category 2 review.
    2. Placed on geotextile fabric or other material where practicable to ensure restoration to the original grade. Soil may not be used to construct or stabilize these structures and rock must be large enough to allow for easy removal without disrupting the streambed.
    3. Designed and maintained to withstand and pass high flows. Water height should be no higher than the top of the culvert’s inlet. A minimum culvert diameter of two feet is required to pass debris. Culverts must be aligned to prevent bank erosion or streambed scour.
    4. Equipped with energy dissipating devices installed downstream if necessary to prevent scour.
    5. Designed and maintained to prevent soil from entering the waterbody.
    6. Removed upon the completion of work. Impacts to the streambed or banks requires restoration to their original condition using stream simulation methods.<sup>2</sup>
- (i) Temporary stream crossings (see h above) or cofferdams shall be used for equipment access across streams (see Appendix F). Note: Areas of fill and/or cofferdams must be included in total waterway/wetlands impacts to determine the review category in Appendix A.
- (j) Maintenance and replacements of stream crossings. An existing stream crossing must be authorized and in compliance with all conditions of its authorization(s) to qualify for maintenance not subject to regulation. See Appendix A, Endnote 15.
- (k) Projects using slip lining (retrofitting an existing culvert by inserting a smaller diameter pipe), plastic pipes and High Density Polyethylene (HDPE) pipes do not qualify for Category 1, either as new work or maintenance activities.
- (l) For Category 1 work: i) No open trench excavation in flowing waters. ii) Management techniques such as temporary flume pipes, culverts, cofferdams, etc. must be used to maintain normal flows within the stream boundary’s confines. iii) Water diversions may be used immediately up and downstream of the work footprint. See Appendix A, Endnote 4.
- (m) For projects that otherwise meet the terms of Category 1, in-stream construction work shall not be conducted during the time of year (TOY) restrictions specified in the MA DMF document referenced in GC 24. For streams not indicated in this document, work may not be conducted from October 1 to June 30. Projects proposed during these TOY restrictions are ineligible for Category 1, regardless of the waterway and wetland fill and/or impact area.

## **22. Wetland Crossings.**

- (a) All temporary and permanent crossings of wetlands shall be suitably culverted, bridged, or otherwise designed to: i) Withstand and prevent the restriction of high flows, ii) Not obstruct the movement of or

not substantially disrupt the necessary life-cycle movements of those species of aquatic life indigenous to the wetland, including those species that normally migrate through the area, beyond the actual duration of construction unless the activity's primary purpose is to impound water.

(b) To qualify for Category 1, new and replacement wetland crossings that are permanent shall be culverted, spanned or bridged in such a manner as to preserve hydraulic and ecological connectivity, at its present level, between the wetlands on either side of the road. To meet this requirement, we recommend that culverts, spans or bridges be placed at least every 50 feet with an opening at least 2 feet high and 3 feet wide at ground level. Closed bottom culverts shall be embedded at least 6 inches with a natural bottom. In addition, see Appendix F for MassDEP's standards.

(c) In the case of non-compliance, the permittee shall take necessary measures to correct wetland damage due to lack of hydraulic connectivity.

(d) Any work that permanently impacts flooding, wetlands on either side of the wetland crossing, or wetland drainage from the upgradient side of the wetland crossing does not qualify for Category 1.

### **23. Discharge of Pollutants.**

(a) All activities involving any discharge of pollutants into waters of the U.S., including wetlands, authorized under this GP shall be consistent with MassDEP's Surface Water Quality Standards and Surface Water Discharge Permit Program Regulations (314 CMR 3.00 and 4.00) and the Wetlands Protection Act (310 CMR 10.00), including Stormwater Management Standards, applicable water quality standards, effluent limitations, standards of performance, prohibitions, and pretreatment standards and management practices established pursuant to the CWA (33 USC 1251), and other applicable state and local laws. If applicable water quality standards, limitations, etc. are revised or modified during the term of this GP, the authorized work shall be modified to conform with these standards within six months of the effective date of such revision or modification, or within a longer period of time deemed reasonable by the Corps in consultation with EPA. Issuance of the WQC confirms that that State water quality standards are met.

(b) All projects authorized by this GP shall be designed, constructed and operated to minimize or eliminate the discharge of pollutants.

(c) All activities involving any discharge of pollutants into waters of the U.S., including wetlands, authorized under this GP must comply with Section 402 [33 U.S.C. 1342] of the Clean Water Act (CWA) and the requirements of the National Pollutant Discharge Elimination System (40 CFR 122).

### **24. Spawning, Breeding and Migratory Areas.**

(a) Activities and impacts such as excavations, discharges of dredged or fill material, and/or suspended sediment producing activities, in fish migratory areas, fish and shellfish spawning or nursery areas, or amphibian and migratory bird breeding areas, during spawning or breeding seasons shall be avoided and minimized to the maximum extent practicable.

(b) To qualify for Category 1, inland and navigable water (e.g., ocean waters, rivers, streams, brooks, embayments, etc.) construction work may not be conducted during the time-of-year restrictions for any *present* species specified in the MA DMF document provided at Appendix F. The TOY restriction for any inland stream not specified in the MA DMF document is October 1 to June 30 (see GC 21(m)).

**25. Storage of Seasonal Structures.** Coastal structures, such as pier sections and floats, that are removed from the waterway for a portion of the year (often referred to as seasonal structures) shall be stored in an upland location, located above mean high water (MHW) and not in tidal wetlands. These seasonal structures may be stored on the fixed, pile-supported portion of the structure that is seaward of MHW. This is intended to prevent structures from being stored on the marsh substrate and the substrate seaward of MHW.



**26. Environmental Functions and Values.** The permittee shall make every reasonable effort to carry out the construction or operation of the work authorized herein in a manner that maintains as much as practicable, and minimizes any adverse impacts on, existing fish, wildlife, and natural environmental functions and values.

**27. Invasive Species.**

(a) The introduction, spread, or the increased risk of invasion of invasive plant or animal species on the project site, into new or disturbed areas, or areas adjacent to the project site caused by the site work is prohibited. See Appendix F.

(b) Unless otherwise directed by the Corps, all applications for Category 2 inland projects proposing fill in Corps jurisdiction shall include an Invasive Species Control Plan (ISCP). See Appendix F.

**28. Inspections.** The permittee shall allow the Corps to make periodic inspections at any time deemed necessary in order to ensure that the work is being or has been performed in accordance with the terms and conditions of this permit. The Corps may also require post-construction engineering drawings for completed work or post-dredging survey drawings for any dredging work. To facilitate these inspections, the permittee shall complete and return to the Corps:

- For Category 1 projects, the Category 1 Form (Appendix C).
- For Category 2 projects, the 1) Work-Start Notification Form and 2) Compliance Certification Form. Both are provided with each Category 2 authorization letter.

**29. Maintenance.** (a) The permittee shall maintain the work authorized herein in good condition and in conformance with the terms and General Conditions of this permit. (b) This does not include maintenance of dredging projects. Maintenance dredging is subject to the review thresholds in Appendix A and/or any special conditions included in a written Corps authorization. Maintenance dredging includes only those areas and depths previously authorized by the Corps and dredged. (c) For inland mosquito ditching and maintenance information, see [www.nae.usace.army.mil](http://www.nae.usace.army.mil), “Regulatory/Permitting,” and then “Useful Links and Documents.”

**30. Property Rights.** This GP does not convey any property rights, either in real estate or material, or any exclusive privileges, nor does it authorize any injury to property or invasion of rights or any infringement of federal, state or local laws or regulations.

**31. Modification, Suspension, and Revocation.** This GP or any work authorized under Category 1 or 2 may be either modified, suspended, or revoked in whole or in part pursuant to the policies and procedures of 33 CFR 325.7. Any such action shall not be the basis for any claim for damages against the United States.

**32. Restoration Directive.** The permittee, upon receipt of a notice of revocation of authorization under this GP, shall restore the wetland or waterway to its former conditions, without expense to the United States and as directed by the Secretary of the Army or his authorized representative. If the permittee fails to comply with such a directive, the Secretary or his designee may restore the wetland or waterway to its former condition, by contract or otherwise, and recover the cost from the permittee.

**33. Special Conditions.** The Corps may independently, or at the request of the federal resource agencies, impose other special conditions on a project authorized pursuant to this GP that are determined necessary to minimize adverse navigational and/or environmental effects or based on any other factor of the public interest. Failure to comply with all conditions of the authorization, including special

conditions, constitutes a permit violation and may subject the permittee to criminal, civil or administrative penalties, and/or restoration.

**34. False or Incomplete Information.** If the Corps makes a determination regarding the eligibility of a project under this GP and subsequently discovers that it has relied on false, incomplete, or inaccurate information provided by the permittee, the GP authorization shall not be valid and the U.S. Government may institute appropriate legal proceedings.

**35. Abandonment.** If the permittee decides to abandon the activity authorized under this GP, unless such abandonment is merely the transfer of property to a third party, he/she may be required to restore the area to the satisfaction of the Corps.

**36. Enforcement Cases.** This GP does not apply to any existing or proposed activity in Corps jurisdiction associated with an on-going Corps or EPA enforcement action, until such time as the enforcement action is resolved or the Corps and/or EPA as appropriate determines that the activity may proceed independently without compromising the enforcement action.

**37. Transfer of GP Verifications.** If the permittee sells the property associated with a GP verification, the permittee may transfer the GP verification to the new owner by submitting a letter to the Corps (see Appendix E for address) to validate the transfer. A copy of the GP verification must be attached to the letter and the letter must contain the following statement and signature: "When the structures or work authorized by this GP are still in existence at the time the property is transferred, the terms and conditions of this GP, including any special conditions, will continue to be binding on the new owner(s) of the property. To validate the transfer of this GP and the associated liabilities associated with compliance with its terms and conditions, have the transferee sign and date below."

**38. Duration of Authorization.** This GP expires on January 20, 2015. Activities authorized under this GP that have commenced (i.e., are under construction) or are under contract to commence before this GP expires will have until January 20, 2016 to complete the activity under the terms and conditions of the current GP.

**39. Previously Authorized Activities.**

(a) Projects that have received written authorization from the Corps and that were completed under the previous PGPs, nationwide permits, regional general permits or letters of permission, shall remain authorized as specified in each authorization letter.

(b) Activities authorized pursuant to 33 CFR 330.3 ("Activities occurring before certain dates") are not affected by this GP.

for J.M. Carthy 1/21/10  
DISTRICT ENGINEER DATE

## APPENDIX A: DEFINITION OF CATEGORIES

<p><b>I. INLAND WATERS AND WETLANDS</b></p>	<p><b>Inland Waters and Wetlands:</b> Waters that are regulated under Section 404 of the Clean Water Act, including rivers, streams, lakes, ponds and wetlands, excluding Section 10 Navigable Waters of the U.S. The jurisdictional limits are the ordinary high water (OHW) mark in the absence of adjacent wetlands, beyond the OHW mark to the limit of adjacent wetlands when adjacent wetlands are present, and the wetland limit when only wetlands are present. For the purposes of this GP, fill placed in the area between the mean high water (MHW) and the high tide line (HTL), and in the bordering and contiguous<sup>1</sup> wetlands to tidal waters are reviewed in the Navigable Waters section (see Appendix A, Page 4).</p> <p>Projects not meeting Category 1 require an application for review as a Category 2 or Individual Permit project.</p> <p>All Category 1 and 2 projects must comply with all of this GP's applicable terms (Pages 1 – 4) and general conditions (Pages 5 – 14).</p>
<p><b>CATEGORY 1</b></p> <p>(a) NEW FILL/ EXCAVATION DISCHARGES (You must reference (b) – (e) below for other thresholds that may be relevant to your project.)</p>	<p><b>CATEGORY 2</b></p> <p>5,000 SF to 1 acre inland waterway and/or wetland fill and associated secondary impacts (e.g., areas drained, flooded, fragmented, mechanically cleared or excavated). Fill area includes all temporary and permanent fill, and regulated discharges associated with excavation. Construction mats and corduroy roads<sup>3</sup> are considered as fill. (See GC 17.)</p> <p>Specific activities with impacts <math>\geq 5,000</math> SF required to affect the containment, stabilization, or removal of hazardous or toxic waste materials performed, ordered, or sponsored by a government agency or Licensed Site Professional with established legal or regulatory authority. Wetlands must typically be restored in place at the same elevation to qualify.</p> <p>The discharge of accumulated bottom sediment from or through a dam into downstream waters.</p> <p>Temporary structures, work, and discharges <math>\geq 5000</math> SF necessary for construction activities or access fills or dewatering of construction sites, provided that the associated primary activity is authorized by the Corps or not subject to Corps regulation. GCs 16-19 are particularly relevant.</p>
<p>(a) NEW FILL/ EXCAVATION DISCHARGES (You must reference (b) – (e) below for other thresholds that may be relevant to your project.)</p>	<p><b>CATEGORY 1</b></p> <p>1. &lt;5,000 SF inland waterway and/or wetland fill and associated secondary impacts<sup>2</sup> (e.g., areas drained, flooded, fragmented, mechanically cleared or excavated). Fill area includes all temporary and permanent fill, and regulated discharges associated with excavation. Construction mats and corduroy roads<sup>3</sup> are considered as fill. (See General Condition (GC) 17.)</p> <p><u>Provided:</u></p> <ul style="list-style-type: none"> <li>● In-water work limited to the TOY windows specified in GC 24.</li> <li>● Historic fill + proposed impact area &lt;5000 SF, and subdivision fill complies with GC 5, Single and Complete Projects.</li> <li>● No work in SAS<sup>6</sup> other than wetlands.</li> </ul> <p>2. Construction mats<sup>3</sup> necessary to conduct activities that are authorized or not subject to regulation (see Endnote 15). Authorized construction mats must be in place for &lt;3 months, removed immediately upon work completion, and the wetlands must be restored (see GC 18).</p> <p>3. The following work is excluded from Cat 1 for all vernal pools (VPs) on, or known VPs surrounding, the project site (see GCs 3&amp;15):</p> <ol style="list-style-type: none"> <li>a. Any work within a VP depression<sup>5</sup>.</li> <li>b. Any work, including roads and driveways, in the VP envelope<sup>5</sup>.</li> <li>c. Any work that individually or cumulatively impacts &gt;25% of the VP critical terrestrial habitat<sup>7</sup>.</li> </ol> <p>* See Appendix D for VP delineation requirements.          * See Appendix F, 5(c) for VP mitigation documents.          * 3b and 3c don't apply to temporary impacts associated with construction mats in previously disturbed areas of existing utility project (e.g., transmission lines, gas pipelines) or linear transportation project (e.g., roads, highways, railways, trails, airport runways and taxiways) right-of-ways provided there is a Vegetation Management Plan that avoids, minimizes and mitigates impacts to aquatic resources.</p>

CATEGORY 1	CATEGORY 2
<p>(b) BANK STABILIZATION PROJECTS</p> <p>(Rivers, streams, brooks &amp; inland waterbodies such as lakes, ponds, etc.)</p>	<p>Inland bank stabilization &lt;100 FT long and &lt;1 CY of fill per linear foot below OHW.</p> <p><u>Provided:</u></p> <ul style="list-style-type: none"> <li>• Work complies with the GCs (GC 20-21 in particular), including: <ul style="list-style-type: none"> <li>○ No structures angled steeper than 3H:1V and only rough-faced stone or fiber roll revetments allowed.</li> <li>○ No open trench excavation in flowing waters. Proper management techniques and water diversions are required (see GC 21(l)).</li> </ul> </li> <li>• Work doesn't occur during the time of year (TOY) restrictions for any <i>present</i> species in streams specified in the MA DMF document referenced in GC 24. The TOY restriction for any streams not specified in the MA DMF document is October 1 to June 30 (see GC 21(m)).</li> <li>• No work in vernal pools<sup>5</sup> or SAS<sup>6</sup>.</li> </ul>
<p>(c) RIVER/STREAM/BROOK WORK &amp; CROSSINGS <i>and</i> WETLAND CROSSINGS</p>	<p>River, stream and brook work and crossings:</p> <ul style="list-style-type: none"> <li>• Must comply with the GCs (GC 21 in particular), including: <ul style="list-style-type: none"> <li>○ Conforming to General Standards (see GC 21(c)).</li> <li>○ No open trench excavation in flowing waters. Proper water diversions and management techniques are required (see GC 21(l)).</li> <li>○ No slip lining (see GC 21(k)).</li> </ul> </li> <li>• Work doesn't occur during the time of year (TOY) restrictions for any <i>present</i> species in streams specified in the MA DMF document referenced in GC 24. The TOY restriction for any streams not specified in the MA DMF document is October 1 to June 30 (see GC 21(m)).</li> <li>• No work in riffles and pools<sup>6</sup>.</li> <li>• No stream relocations.</li> </ul>
<p>(d) REPAIR, REPLACEMENT &amp; MAINTENANCE OF AUTHORIZED FILLS.</p>	<p>Wetland crossings must comply with the particularly relevant GC 22,</p> <p>Repair/maintenance of currently-serviceable, authorized fills with no expansion or change in use.</p> <ul style="list-style-type: none"> <li>• Conditions of the original authorization apply.</li> <li>• Minor deviations in fill design allowed<sup>11</sup>.</li> </ul>

Work not qualifying for Category 1.

Work not qualifying for Category 1.

Repair/maintenance of currently serviceable authorized fills, or replacement of non-serviceable authorized fills, <1 acre, including expansion or a change in use.

Replacement of non-serviceable authorized fills, including expansion or a change in use, totaling <1 acre.

	CATEGORY 1	CATEGORY 2
(e) MISC.	<p>Oil spill clean-up fill done in accordance with the Massachusetts Contingency Plan 310 CMR 40.0000 or under state emergency certification 310 CMR 10.06. SAS<sup>6</sup> must typically be restored in place at the same elevation.</p> <p>Scientific measurement devices whose purpose is to measure and record scientific data, such as staff gages, water recording devices, water quality testing and improvement devices, and similar structures. Structures may not restrict movement of aquatic organisms.</p> <p>Survey activities, such as core sampling, seismic exploratory operations, plugging of seismic shot holes and other exploratory-type bore holes, exploratory trenching, soil surveys, sampling, and historic resources surveys (but not recovery). Exploratory trenches must be restored in accordance with GC 19. The construction of temporary pads is authorized provided the discharge doesn't exceed 25 CY. This doesn't authorize permanent structures or the drilling and the discharge of excavated material from test wells for oil and gas exploration (the plugging of such wells is authorized).</p> <p>Any work not commenced nor completed that was authorized in a written letter from the Corps under the PGP in effect between December 18, 2006 and January 20, 2010. The terms and general conditions of this GP apply along with any special conditions in the written authorization.</p>	<p>Aquatic habitat restoration, establishment, and enhancement of wetlands and riparian areas and the restoration and enhancement of streams and other open waters with impacts of any area <math>\geq 5,000</math> SF, provided those activities result in net increase in overall aquatic resource functions and services.<sup>9</sup></p> <p>Projects where an EIS is required by the Corps are not eligible for Category 2.</p>

<p><b>II. NAVIGABLE WATERS</b></p>	<p><b>Navigable Waters of the U.S.:</b> Waters that are subject to the ebb and flow of the tide and federally designated navigable rivers (the Merrimack River, Connecticut River, and Charles River to the Watertown Dam in Massachusetts) (Section 10 Rivers and Harbors Act of 1899). The jurisdictional limits are the mean high water (MHW) line in tidal waters and the ordinary high water (OHW) mark in non-tidal portions of the federally designated navigable rivers. For the purposes of this GP, fill placed in the area between MHW and the high tide line (HTL), and in the bordering and contiguous wetlands<sup>1</sup> to tidal waters are also reviewed in this Navigable Waters section.</p> <p>Projects not meeting Category 1 require an application for review as a Category 2 or Individual Permit project.</p> <p>All Category 1 and 2 projects must comply with all of this GP's applicable terms (Pages 1 – 4) and general conditions (Pages 5 – 14).</p>	
	<p><b>CATEGORY 1</b></p> <p>No provisions for new or previously unauthorized fills in Category 1, other than:</p> <ul style="list-style-type: none"> <li>• Fills authorized under the MA Chapter 91 Amnesty program. (e.g., seawalls or bulkheads).</li> <li>• Discharges of dredged or fill material incidental to the construction of bridges across navigable waters of the U.S., including cofferdams, abutments, foundation seals, piers, and temporary construction and access fills provided the U.S. Coast Guard authorizes such discharges as part of the bridge permit or appropriate approval. Causeways and approach fills are not included in this category and require Category 2 or Individual Permit authorization.</li> </ul>	<p><b>CATEGORY 2</b></p> <p>&lt;1 acre waterway fill and secondary waterway impacts (e.g., areas drained, flooded, fragmented or mechanically cleared). Fill area includes all temporary and permanent waterway fills.</p> <p>Temporary fill and/or excavation &lt;1 acre in SAS<sup>6</sup>.</p> <p>No permanent fill or excavation in SAS<sup>6</sup>.</p>
<p><b>(b) REPAIR AND MAINTENANCE WORK</b></p>	<p>Repair, replacement in kind or maintenance<sup>13</sup> of:</p> <ul style="list-style-type: none"> <li>• Existing, currently serviceable, authorized fills and structures</li> <li>• Amnesty-approved fills and structures:</li> </ul> <p><u>Provided:</u></p> <ul style="list-style-type: none"> <li>• No expansion or change in use.</li> <li>• Must be rebuilt in same footprint, however minor deviations in structure design allowed<sup>13</sup></li> </ul>	<p>Repair/maintenance of currently serviceable authorized fills, or replacement of non-serviceable authorized fills, &lt;1 acre, including expansion or a change in use.<sup>13</sup></p> <p>Repair/maintenance<sup>13</sup> of currently serviceable authorized structures w/expansion where the structure (existing + expansion) qualifies for Cat 2 [see (e) below].</p> <p>Replacement of non-serviceable, authorized structures where the structure (existing + expansion, if any) qualifies for Cat 2 [see (e) below].</p>

CATEGORY 1	CATEGORY 2
<p>(c) DREDGING/ EXCAVATION AND ASSOCIATED DISPOSAL</p> <p>Maintenance dredging<sup>14</sup> for navigational purposes &lt;1,000 CY with upland disposal. Includes return water from upland contained disposal area.</p> <p><u>Provided:</u></p> <ul style="list-style-type: none"> <li>• Proper siltation controls are used.</li> <li>• No impacts to SAS<sup>6</sup>.</li> <li>• No dredging in intertidal areas.</li> <li>• No dredging in Areas of Critical Environmental Concern (ACEC's). The MA Secretary of Environmental Affairs designates ACECs and lists them: <a href="http://www.mass.gov/dem/programs/acec/">www.mass.gov/dem/programs/acec/</a>.</li> <li>• Work doesn't occur during the time of year (TOY) restrictions for any <i>present</i> species in waters specified in the MA DMF document referenced in GC 24.</li> </ul>	<p>Maintenance dredging<sup>14</sup> ≥1,000 CY, new dredging &lt;25,000 CY, or projects not meeting Category 1.</p> <p><u>Provided:</u></p> <ul style="list-style-type: none"> <li>• No impacts to SAS<sup>6</sup>.</li> <li>• Disposal includes: 1. upland; 2. beach nourishment of any area provided dredging's primary purpose is navigation or sand is from an upland source and Corps, in consultation w/federal and state agencies, determines the net adverse effects are not more than minimal; or 3. open water &amp; confined aquatic disposal, if Corps, in consultation with federal and state agencies, finds the material suitable.</li> <li>• Includes return water from upland contained disposal areas.</li> </ul>
<p>(d) MOORINGS</p> <p>Private, non-commercial, non-rental, single-boat moorings authorized under MGL Chapter 91 Section 10A.</p> <p><u>Provided:</u></p> <ul style="list-style-type: none"> <li>• Not associated with any boating facility<sup>10</sup>, including those in a Federal Anchorage<sup>11</sup>.</li> <li>• Not located within the buffer zone of the horizontal limits of a Federal Channel<sup>11</sup>.</li> <li>• No interference with navigation.</li> <li>• Not located in vegetated shallows<sup>12</sup>.</li> <li>• Not located in SAS<sup>6</sup> (excluding vegetated shallows) unless conservation/eco-friendly moorings are used, which shall prevent the chain/rope from resting or dragging on the bottom substrate at all tides, and utilize a helical anchor where practicable.</li> </ul>	<p>Moorings that don't meet the terms of Category 1 and don't require an Individual Permit.</p> <p>Moorings associated with a boating facility<sup>10</sup>.</p> <p>Moorings located such that they, and/or vessels docked or moored at them, are within the buffer zone of the horizontal limits of a Federal Channel<sup>11</sup>. (See Appendix I.)</p> <p>Moorings and/or their moored vessels within the horizontal limits of a Federal Channel<sup>11</sup> (see Appendix I) are not eligible for Category 2 and require an Individual Permit.</p> <p>Any work in the area of the Cape Cod Canal<sup>14</sup> located west of the vertical lift railroad bridge as noted in Endnote 14 and Appendix J is not eligible for Category 2 and requires an Individual Permit.</p>

CATEGORY 1	CATEGORY 2	CATEGORY 2
<p>(e) PILE-SUPPORTED STRUCTURES AND FLOATS</p>	<p>Private, bottom-anchored floats <math>\leq 400</math> SF.</p> <p>Private, pile-supported structures that aren't boating facilities<sup>10</sup> for navigational access to the waterway <math>\leq 400</math> SF with attached floats totaling <math>\leq 200</math> SF.</p> <p><u>Provided (for all of the above):</u></p> <ul style="list-style-type: none"> <li>• Floats supported at least 2.5' above the substrate during all tides.</li> <li>• Pile-supported structures &amp; floats are not positioned over vegetated shallows<sup>12</sup> and moored vessels are not positioned over SAS<sup>6</sup>.</li> <li>• No structure located within 25' of any vegetated shallows<sup>12</sup>.</li> <li>• Pile-supported structures: <ul style="list-style-type: none"> <li>○ <math>\leq 4'</math> wide and at least a 1:1 height:width ratio<sup>13</sup>,</li> <li>○ pilings spaced <math>\geq 20x</math> the diameter of the piling,</li> <li>○ cross or transverse bracing higher than MHW,</li> <li>○ planks spaced <math>\geq \frac{3}{4}</math> inch to permit light penetration (alternate spacing acceptable if in accordance with "Plank Spacing" on Page 17 of DEP's "A Guide to Permitting Small, Pile-Supported Docks and Piers."). (See Appendix F.)</li> </ul> </li> <li>• Ch. 91 license issued.</li> <li>• Not associated with a boating facility<sup>10</sup>.</li> <li>• Not located within the buffer zone of the horizontal limits of an FNP<sup>11</sup>.</li> <li>• No structure extends across <math>&gt;25\%</math> of the waterway width at MLW.</li> </ul>	<p>Private structures or floats that aren't associated with a new or previously unauthorized boating facility<sup>10</sup> and that don't meet the terms in Cat. 1.</p> <p>Modifications or expansions to existing, authorized boating facilities<sup>10</sup>.</p> <p>Pile-supported structures or floats and/or vessels docked or moored at them within the buffer zone of the horizontal limits of a Corps FNP<sup>11</sup>.</p> <p>Pile-supported structures or floats located such that they and/or vessels docked or moored at them are within the horizontal limits of a Corps FNP<sup>11</sup> are not eligible for Category 2 and require an Individual Permit.</p> <p>Any work in the area of the Cape Cod Canal<sup>14</sup> located west of the vertical lift railroad bridge as noted in Appendix J and Endnote 14 is not eligible for Category 2 and requires an Individual Permit.</p> <p>Establishment of a marina reconfiguration zone is not eligible for Category 2 and requires an Individual Permit.</p>
<p>(f) MISCELLANEOUS</p>	<p>Piers /structures licensed by Ch. 91 through the Amnesty program.</p> <p>Temporary buoys, markers, floats, and similar structures for recreational use during specific events, provided they are removed with 30 days after use is discontinued.</p> <p>The placement of aids to navigation and regulatory markers which are approved by and installed in accordance with the requirements of the U.S. Coast Guard. (See 33 CFR 66, Chapter I, C.)</p> <p>Oil spill clean-up structures and fill done in accordance with the Massachusetts Contingency Plan 310 CMR 40.0000 or under state emergency certification 310 CMR 10.06. SAS<sup>6</sup> must typically be restored in place at the same elevation.</p>	<p>Structures or work in or affecting tidal or navigable waters that are not defined under any of the previous headings listed above. Includes, but is not limited to, utility lines, aerial transmission lines, pipelines, outfalls, boat ramps, bridges, tunnels and horizontal directional drilling activities seaward of the MHW line.</p> <p>Shellfish aquaculture facilities in compliance with the Aquaculture Guidelines (see Appendix K).</p> <p>Aquatic habitat restoration, establishment, and enhancement of tidal wetlands and riparian areas provided those activities are proactive and result in net increases in aquatic resource functions and services.<sup>9</sup></p>



	CATEGORY 1	CATEGORY 2
<p>(f) MISCELLANEOUS (continued)</p>	<p>Fish and wildlife harvesting, enhancement, and attraction devices and activities such as pound nets, crab traps, crab dredging, eel pots, lobster traps, and clam and oyster digging, and small fish attraction devices such as open water fish concentrators (sea kites, etc.). This does not authorize artificial reefs or impoundments and semi-impoundments of waters of the U.S. for the culture or holding of motile species such as lobster, or the use of covered oyster trays or clam racks. No activity in SAS and no hazard to navigation.</p> <p>Test plots &lt;100 SF for the planting of wetland species native to the area. No grading, no plant growing devices and no interference with navigation.</p> <p>Temporary structures must be removed within 60 days</p> <p>Scientific measurement devices whose purpose is to measure and record scientific data, such as staff gages, tide gages, water recording devices, water quality testing and improvement devices, and similar structures. Structures may not restrict movement of aquatic organisms.</p> <p>Survey activities, such as core sampling, seismic exploratory operations, plugging of seismic shot holes, and other exploratory-type bore holes, exploratory trenching, soil surveys, sampling, and historic resources surveys (but not recovery). This does not authorize fill or work in SAS, permanent structures or the drilling and the discharge of excavated material from test wells for oil and gas exploration (the plugging of such wells is authorized).</p> <p>Any work not commenced nor completed that was authorized in a written letter from the Corps under the PGP in effect between December 18, 2006 and January 20, 2010. The terms and general conditions of this GP apply along with any special conditions in the written authorization. This does not allow continued disposal of dredged material at the Massachusetts Bay Disposal Site.</p>	<p>Specific activities with impacts of any area required to affect the containment, stabilization, or removal of hazardous or toxic waste materials that are performed, ordered, or sponsored by a government agency or Licensed Site Professional with established legal or regulatory authority. Wetlands must typically be restored in place at the same elevation to qualify.</p> <p>Projects where an EIS is required by the Corps are not eligible for Category 2.</p>

## Endnotes/Definitions

<sup>1</sup> **Bordering and Contiguous Wetlands:** A bordering wetland is immediately next to its adjacent waterbody and may lie at, or below, the ordinary highwater mark (MHW in navigable waters) of that waterbody and is directly influenced by its hydrologic regime. Contiguous wetlands extend landward from their adjacent waterbody to a point where a natural or manmade discontinuity exists. Contiguous wetlands include bordering wetlands as well as wetlands that are situated immediately above the ordinary highwater mark and above the normal hydrologic influence of their adjacent waterbody. Note, with respect to the federally designated navigable rivers, the wetlands bordering and contiguous to the tidally influenced portions of those rivers are reviewed under “II. Navigable Waters”.

## <sup>2</sup> **Direct, Secondary, and Cumulative Impacts/Effects:**

Direct Impacts: The immediate loss of aquatic ecosystem within the footprint of the fill.

Secondary Effects: These are effects on an aquatic ecosystem that are associated with a discharge of dredged or fill materials, but do not result from the actual placement of the dredged or fill material. Information about secondary effects on aquatic ecosystems shall be considered prior to the time final section 404 action is taken by permitting authorities. Some examples of secondary effects on an aquatic ecosystem are a) fluctuating water levels in all impoundment and downstream associated with the operation of a dam, b) septic tank leaching and surface runoff from residential or commercial developments on fill, and c) leachate and runoff from a sanitary landfill located in waters of the U.S. Put another way, secondary effects are those impacts outside the footprint of the fill that arise from and are associated with the discharge of dredged or fill material, including the operation of an activity or facility associated with the discharge. Examples may include habitat fragmentation; interruption of travel corridors for wildlife (for example, for amphibians that migrate to and from seasonal or vernal pools used as breeding habitat); hydrologic regime changes; and impacts from operation and maintenance activities for constructed facilities; such as noise/lighting, storm water runoff, and road kill of wetland dependent wildlife. Using the directions contained in the guidelines, we consider the circumstances of a proposed discharge and the project of which it is a part to evaluate the scope, extent, severity, and permanence of direct, secondary, and cumulative adverse effects upon the aquatic ecosystem.

Cumulative Impacts: The extent of past, present, and foreseeable developments in the area may be an important consideration in evaluating the significance of a particular project's impacts. Although the impacts associated with a particular discharge may be minor, the cumulative effect of numerous similar discharges can result in a large impact. Cumulative impacts should be estimated only to the extent that they are reasonable and practical.

<sup>3</sup> **Construction Mats:** Constructions, swamp and timber mats (herein referred to as “construction mats”) are generic terms used to describe structures that distribute equipment weight to prevent wetland damage while facilitating passage and providing work platforms for workers and equipment. They are comprised of sheets or mats made from a variety of materials in various sizes. A timber mat consists of large timbers bolted or cabled together. Corduroy roads, which are not considered to be construction mats, are cut trees and/or saplings with the crowns and branches removed, and the trunks lined up next to one another. Corduroy roads are typically installed as permanent structures. Like construction mats, they are considered as fill whether they're installed temporarily or permanently.

<sup>4</sup> **Water Diversions:** Water diversions are activities such as bypass pumping or water withdrawals. Temporary flume pipes, culverts or cofferdams where normal flows are maintained within the stream boundary's confines aren't water diversions. “Normal flows” are defined as no change in flow from pre-project conditions.

<sup>5</sup> **Vernal Pools (VP):** For the purposes of this PGP, these are 1) Certified VPs and Potential VPs as defined by the Massachusetts Natural Heritage and Endangered Species Program (NHESP), and 2) depressions that meet the Certification Criteria in NHESP's “Guidelines for the Certification of Vernal Pool Habitat” at [www.mass.gov/dfwele/dfw/nhesp/nhesp.htm](http://www.mass.gov/dfwele/dfw/nhesp/nhesp.htm) under “Vernal Pools.” The Corps may determine during a Category 2 review that a waterbody should not be regulated as a VP based on available evidence. The Corps VP management areas are the: Vernal Pool Depression, Vernal Pool Envelope (area within 100 FT of the VP Depression's edge) and Critical Terrestrial Habitat (area within 100-750 FT of the VP Depression's edge). When there is no distinct and clear topographic break at the edge of a VP Depression, the maximum observed or recorded extent of flooding represents the ecological boundary of the VP Depression.

<sup>6</sup> **Special Aquatic Sites (SAS):** Includes wetlands and saltmarsh, mudflats, riffles and pools, vegetated shallows, coral reefs, and sanctuaries and refuges which consist of areas designated under state and federal laws or local ordinances to be managed principally for the preservation and use of fish and wildlife resources.

Note: All SAS<sup>6</sup> within the project area shall be delineated on the plans for Category 2 and IP applications.

<sup>7</sup> **In-Lieu Fee or Mitigation Bank Documents:** See [www.nae.usace.army.mil/reg](http://www.nae.usace.army.mil/reg) and then “Mitigation.”

<sup>8</sup> **Corps Properties & Easements:** Contact the Corps, Real Estate Division (978) 318-8585 to initiate reviews about both Corps holdings and permit requirements.

<sup>9</sup> **Aquatic Habitat Restoration, Establishment and Enhancement:** The Corps will decide if a project qualifies and must determine in consultation with federal and state agencies that the net effects are beneficial. The Corps may refer to Nationwide Permit 27 published in the 3/12/07 Federal Register. Activities authorized here may include, but are not limited to: the removal of accumulated sediments; the installation, removal, and maintenance of small water control structures, dikes,

and berms; the installation of current deflectors; the enhancement, restoration, or establishment of riffle and pool stream structure; the placement of in-stream habitat structures; modifications of the stream bed and/or banks to restore or establish stream meanders; the backfilling of artificial channels and drainage ditches; the removal of existing drainage structures; the construction of small nesting islands in inland waters; the construction of open water areas; the construction of native shellfish species habitat over unvegetated bottom for the purpose of habitat protection or restoration in tidal waters; shellfish seeding; activities needed to reestablish vegetation, including plowing or discing for seed bed preparation and the planting of appropriate wetland species; mechanized land clearing to remove non-native invasive, exotic, or nuisance vegetation; and other related activities. Only native plant species should be planted at the site.

<sup>10</sup> **Boating Facilities:** Facilities that provide for a fee, rent, or sell mooring space, such as marinas, yacht clubs, boat clubs, boat yards, town facilities, dockminiums, etc.

<sup>11</sup> **Federal Navigation Projects (FNPs):** FNPs are comprised of Federal Channels and Federal Anchorages. See Appendix I for their location and contact the Corps for more information. “Horizontal Limits” is the outer edge of an FNP. “Buffer Zone” is equal to three times the authorized depth of that channel.

<sup>12</sup> **Vegetated Shallows:** Subtidal areas that support rooted aquatic vegetation such as eelgrass and widgeon grass (Rupiamaritima). (Doesn’t include salt marsh.)

<sup>13</sup> **Height: Width Ratio:** The height of structures shall at all points be equal to or exceed the width of the deck. For the purpose of this definition, height shall be measured from the marsh substrate to the bottom of the longitudinal support beam.

<sup>14</sup> **Cape Cod Canal:** The Individual Permit area begins approximately 1,000 feet west of the Cape Cod Canal vertical lift railroad bridge and continues westerly approximately 3,000 feet along the center line of the channel to the end of the area (NOAA Reference Chart 13236). See Appendix J.

<sup>15</sup> **Maintenance:** In accordance with 33 CFR 323.4(a)(2), any discharge of dredged or fill material that may result from any of the following activities is not prohibited by or otherwise subject to regulation under Section 404 of the CWA: “Maintenance, including emergency reconstruction of recently damaged parts, of currently serviceable structures such as dikes, dams, levees, groins, riprap, breakwaters, causeways, bridge abutments or approaches, and trans-portionation structures. Maintenance does not include any modification that changes the character, scope, or size of the original fill design.” (This could include replacement work if it meets this definition, and stream crossings typically must be an exact replica crossing in the same footprint to qualify.) Otherwise, the following work is regulated and subject to the Category 1 or 2 thresholds in Appendix A above: The repair, rehabilitation, or replacement of any previously authorized, currently serviceable structure or fill, or of any currently serviceable structure or fill authorized by 33 CFR 330.3 – “Activities occurring before certain dates,” provided that the structure or fill is not to be put to uses differing from those uses specified or contemplated for it in the original permit or the most recently authorized modification. Minor deviations in the structure’s configuration or filled area, including those due to changes in materials, construction techniques, or current construction codes or safety standards that are necessary to make the repair, rehabilitation, or replacement are authorized. Currently serviceable means useable as is or with some maintenance, but not so degraded as to essentially require reconstruction. Only structures or fills that were previously authorized and are in compliance with the terms and condition of the original authorization can be maintained as a non-regulated activity under 33 CFR 323.4(a)(2), or in accordance with the Category 1 or 2 thresholds in Appendix A. Note: The state’s maintenance provisions may differ from the Corps and may require reporting and written authorization from the state.

<sup>16</sup> **Maintenance Dredging:** This includes only those areas and depths previously authorized by the Corps and dredged.

## Appendix B: 401 Water Quality Certification

For work in Corps jurisdiction involving a discharge to waters of the U.S., including wetlands, an Individual 401 WQC must be obtained from or waived by the Massachusetts DEP before work can proceed as authorized by this GP for the following circumstances (pursuant to MGL c. 21 Sections 26 - 53 and regulations at 314 CMR 9.00). The following are excerpted from the MassDEP regulations at 314 CMR 9.04: Activities Requiring an Application, and require an Individual 401 WQC application:

- (1) *More than 5000 SF.* Any activity in an area subject to 310 CMR 10.00 which is also subject to 33 USC 1251, et seq. and will result in the loss of more than 5000 SF cumulatively of bordering and isolated vegetated wetlands and land under water.
- (2) *Outstanding Resource Waters. Dredging in, or any activity resulting in any discharge of dredged or fill material to any Outstanding Resource Water.*
- (3) *Real Estate Subdivision -* Any discharge of dredged or fill material associated with the creation of a real estate subdivision, unless there is a valid, unexpired Final Order of Conditions, followed by a Certificate of Compliance, and a recorded deed restriction providing notice to subsequent purchasers limiting the amount of fill for the single and complete project to less than 5000 square feet cumulatively of bordering and/or isolated vegetated wetlands and land under water and the discharge is not to an Outstanding Resource Water. Real estate subdivisions include divisions where approval is required and where approval is not required under the Subdivision Control Law, MGL. c. 41, §81K through 81GG. Discharges of dredged or fill material to create the real estate subdivision include but are not limited to discharges resulting from the construction of roads, drainage, sidewalks, sewer systems, buildings, septic systems, wells, and accessory structures.
- (4) *Activities Exempt under MGL. c. 131, §40.* Any activity not subject to MGL. c. 131, §40 and which is subject to 33 USC 1251, et seq. and will result in any discharge of dredged or fill material to bordering vegetated wetlands or land under water.
- (5) *Routine Maintenance.* Routine maintenance of existing channels, such as mosquito control projects or road drainage maintenance, that will result in the annual loss of more than 5000 square feet cumulatively of bordering and isolated vegetated wetland and land under water will be evaluated under the criteria of 314 CMR 9.06. A single application may be submitted and a single certification may be issued for repeated routine maintenance activities on an annual or multi-year basis not to exceed five years.
- (6) *More than 5000 sq. ft. of Isolated Vegetated Wetlands.* Any activity in an area not subject to jurisdiction of MGL. c. 131, §40 but which is subject to 33 U.S.C.1251, et seq. (i.e., isolated vegetated wetlands) which will result in the loss of more than 5000 square feet cumulatively of bordering and isolated vegetated wetlands and land under water.
- (7) *Rare and Endangered Species Habitat in Isolated Vegetated Wetlands.* Any activity resulting in the discharge of dredged or fill material to an isolated vegetated wetland that has been identified as habitat for rare and endangered species.
- (8) *Salt Marsh.* Any activity resulting in the discharge of dredged or fill material in any salt marsh.
- (9) *Individual 404 Permit.* Any activity that is subject to an Individual Permit under Section 404 of the Clean Water Act by the Corps of Engineers.
- (10) *Agricultural Limited Project.* Agricultural work, not exempt under MGL. c. 131, §40, referenced in and

performed in accordance with 310 CMR 10.53(5). Provided the activity does not result in any discharge of dredged or fill material to an Outstanding Resource Water, such work will be presumed to meet the criteria of 314 CMR 9.06 where a comparable alternatives analysis is performed or approved by the Natural Resources Conservation Service and included in the Notice of Intent.

(11) *Discretionary Authority*. Any activity where the Department invokes discretionary authority to require an application based on cumulative effects of multiphased activities, cumulative effects of dredging, or from the discharge of dredged or fill material to bordering or isolated vegetated wetlands or land under water, or other impacts that may jeopardize water quality. The Department will issue a written notice of and statement of reasons for its determination to invoke this discretionary authority not later than ten business days after its receipt of an Order of Conditions.

(12) *Dredging Greater than 100 c.y.* Any dredging or dredged material disposal of more than 100 cubic yards not meeting the requirements of 314 CMR 9.03(3).

(13) Any activity not listed in 314 CMR 9.03 or 314 CMR 9.04 is an activity requiring an application subject to the requirements of 314 CMR 9.05 and 9.06 through 9.13 as applicable..



**US Army Corps  
of Engineers**®  
New England District

**Appendix C: Category 1 Form**  
(for all Inland and Navigable Water Projects in Massachusetts)

Submit this **before** work commences to the following address. Call (978) 318-8335 with any questions.  
 Chief, Permits & Enforcement Branch (MA)  
 New England District  
 U.S. Army Corps of Engineers  
 696 Virginia Road  
 Concord, MA 01742-2751

Permittee: \_\_\_\_\_

Permittee Address: \_\_\_\_\_

City, State & Zip Code: \_\_\_\_\_

Phone(s) and Email: \_\_\_\_\_

Work Locations/Address: \_\_\_\_\_

City, State & Zip Code: \_\_\_\_\_

Latitude/Longitude coordinates: \_\_\_\_\_

Waterway name: \_\_\_\_\_

Work will be done under the following Appendix A categories (circle all that apply):

- I. Inland Waters and wetlands:      a.      b      c      d      e
- II. Navigable Waters:                      a      b      c      d      e      f

Area of wetland impact: \_\_\_\_\_ square feet (SF)

Area of waterway impact: \_\_\_\_\_ SF

Area of compensatory mitigation provided: \_\_\_\_\_ SF

Will American Recovery and Reinvestment Act (ARRA) funds be used for any of this project? \_\_\_\_\_

Contractor: \_\_\_\_\_

Contractor Address: \_\_\_\_\_

City, State & Zip Code: \_\_\_\_\_

Phone(s) and Email: \_\_\_\_\_

Proposed Work Dates: Start: \_\_\_\_\_ Finish: \_\_\_\_\_

Your signature below, as permittee, indicates that you accept and agree to comply with the terms, eligibility criteria, and conditions of Category 1 of this Massachusetts General Permit.

Permittee Signature: \_\_\_\_\_ Date: \_\_\_\_\_



**US Army Corps  
of Engineers**®  
New England District

## Appendix D: Information Required Checklist (Category 2 & Individual Projects)

All applicants for Category 2 and Individual Projects must submit this checklist with their application to the MassDEP or Corps (see Page 3) and include at least the following information. Project applications will be considered complete upon 1) the Corps receipt of the necessary information in this checklist and 2) the MassDEP site inspection. For a more comprehensive checklist, see [www.nae.usace.army.mil/reg](http://www.nae.usace.army.mil/reg), “Forms” and then “Application and Plan Guideline Checklist.” Check with our office for project-specific requirements.

Applicant: \_\_\_\_\_ Date: \_\_\_\_\_

Address: \_\_\_\_\_

City, State & Zip Code: \_\_\_\_\_

### All Projects:

- MassDEP 401 WQC or Chapter 91 application forms (see Page 3, III.3) or Corps application form as appropriate.
- Indicate that the MHC PNF was submitted to the appropriate groups listed in III.3.c on Page 3.
- Purpose of the project.
- Legible, reproducible black and white (no color) plans no larger than 11”x17” with bar scale. Provide locus map and plan views of the entire property.
- Typical cross-section views of all wetland and waterway fill areas and wetland replication areas.
- On each plan, show the following for the project when applicable:
  - Vertical datum and the NAVD 1988 equivalent with the vertical units as U.S. feet. Don’t use local datum;
  - Horizontal state plane coordinates in U.S. survey feet based on the [insert state grid system] for the [insert state] [insert zone] NAD 83.
- Show project limits with existing and proposed conditions.
- Volume, type, and source of fill material to be discharged into waters and wetlands, including the area(s) (in square feet or acres) of fill in wetlands, below the ordinary high water in inland waters and below the high tide line in coastal waters.
- Photographs of wetland/waterway to be impacted.
- Volume, type, and source of fill material to be discharged into waters and wetlands, including the area(s) (in square feet or acres) of fill in wetlands, below the ordinary high water in inland waters and below the high tide line in coastal waters.
- Provide information on secondary and cumulative effects associated with the project. See GC 3.
- Provide information on any federal or state authorized work, wetland/waterway fill, or conservation restrictions or easements associated with the project. See GC 5.
- The name(s) of federal endangered and threatened “listed species or habitat” present in the action area (see GC 10 and Appendix F).
- The Corps will review alternatives analysis submitted to the DEP for WQC review. Include any additional information compiled on alternatives. See GC 15.
- A statement describing how the mitigation requirement will be satisfied. As an alternative, the prospective permittee may submit a conceptual or detailed mitigation plan.

## **Inland Waters**

- Delineation of all waters of the United States on the project site, including special aquatic sites and vernal pools. Use federal delineation methods and include Corps wetland delineation data sheets (see GC 2, and Appendix A - Endnotes 5 and 6).
- Invasive Species Control Plan (see GC 27).

## **Stream Crossings (see the design and construction manual referenced in Appendix F).**

(1) Plans showing the following information:

- Structure location including inlet and outlet inverts located with x, y, z coordinates or equivalent and taken from the long profile.
- Extension of channel excavation and filling.
- Road locations, edges, centerline, geometric description of curvature, widths, and curve widening, p-line or x, y, z coordinates.
- Channel work identified including bank erosion control features, grade control, and channel linings.
- Estimated drainage area at the crossing location.

(2) Streambed details, with figures, which show the following:

- The distance from the top of the right bank to the top of the left bank.
- Average stream approach channel slope and percent gradient within the crossing, measured using a clinometer, hand level or other survey equipment.
- A shaped streambed in the structure, usually sloping downward toward the center to form a low-water channel.
- Approximate elevations, spacing, diameters, and locations of rocks for steps, bankline, and other channel rocks for roughness.
- Details for sediment retention structures, if any, within embedded structures.
- A visual estimate of dominant channel materials upstream, downstream, and if applicable, within the existing crossing.
- The streambed simulation materials and its extent, depth and length within the crossing.
- Pebble count upstream, downstream, and if applicable, within the existing crossing.
- Channel information for the design reference reach including bank full width, bankfull depth, entrenchment ratio, sinuosity, flood prone width, a long profile that is 7-10 bankfull widths long with grade controls, pools and gradients shown, an appropriate reference reach cross section with channel details, reference reach pebble count, including a narrative explaining why the cross section is considered representative.

(3) Existing crossing metrics on the plan, including:

- Existing riparian zone, including the extent and type of existing vegetation surrounding or in the stream bank.
- Existing crossing type and dimensions, including material, length, and dimensions.
- Existing tailwater control, including its location and materials, and pool configuration.

(4) The dewatering system as follows:

- Estimates of the maximum flow anticipated during construction, including any summer storm estimates;
- Location, height, and width of the diversion dam.
- Sump locations, including estimate of necessary flow and sump capacity.
- Backwater prevention method.
- Sediment treatment plan with methods, release point, and extent.

(5) Structural details of the crossing, including the following:

- Structural section, gauge or thickness, and material, minimum and maximum cover limits;



- Structures, drawn to scale, on elevation view showing bed material location relative to structure, and special backfill zones;
- Structural excavation quantity and total excavation estimate.
- Footing depth and width for spans (bottomless arches, open-bottom culverts, bridges, etc).

(6) Impact Analysis:

- Crossing impact assessment to wildlife and fisheries and aquatic organisms (pre- and post design) including direct and secondary impacts.
- Replacements: an analysis of current crossing compatibility, stability of upstream and downstream channel and bank, recent scour events, systems analysis on hydrology, ecological stability and sediment loading.

**Waters subject to the ebb and flow of the tide**

- On each plan show the vertical datum and the NAVD 1988 equivalent with the vertical units as U.S. feet. Don't use local datum. In coastal waters this may be mean higher high water (MHHW), mean high water (MHW), mean low water (MLW), mean low lower water (MLLW) or other tidal datum with the vertical units as U.S. feet. MLLW and MHHW are preferred. Provide the correction factor detailing how the vertical datum (e.g., MLLW) was derived using the latest National Tidal Datum Epoch for that area, typically 1983-2001.
- Show the high tide line (HTL) elevations when fill is involved
- Limits of any Federal Navigation Project in the vicinity of the project area and horizontal State Plane Coordinates in U.S. survey feet for the limits of the proposed work closest to the Federal Navigation Project;
- Delineation of all waters of the United States on the project site, including special aquatic sites and vegetated shallows (e.g., eelgrass beds). Use federal delineation methods and include Corps wetland delineation data sheets (See GC 2, and Appendix A - Endnotes 5 and 6).
- Identify and describe potential impacts to Essential Fish Habitat (see General Condition 11).

**Information typically required for dredging projects:**

- Sediment testing, including physical (e.g., grain-size analysis), chemical and biological testing. For projects proposing open water disposal, applicants are encouraged to contact the Corps as early as possible regarding sampling and testing protocols. Sampling and testing of sediments without such contact should not occur and if done, would be at the applicant's risk.
- The area in square feet and volume of material to be dredged below mean high water.
- Existing and proposed water depths.
- Type of dredging equipment to be used.
- Nature of material (e.g., silty sand).
- Any existing sediment grain size and bulk sediment chemistry data for the proposed or any nearby projects.
- Information on the location and nature of municipal or industrial discharges and occurrence of any contaminant spills in or near the project area.
- Location of the disposal site (include locus sheet).
- Identify and describe potential impacts to Essential Fish Habitat (see General Condition 11).
- Delineation of submerged aquatic vegetation (e.g., eelgrass beds).

## Appendix E: Contacts and Tribal Areas of Interest

### 1. FEDERAL

U.S. Army Corps of Engineers  
Regulatory Division  
696 Virginia Road  
Concord, Massachusetts 01742-2751  
(978) 318-8335, (800) 362-4367 (MA)  
(800) 343-4789 (ME, VT, NH, RI, CT)

#### **Federal Endangered Species and Essential Fish Habitat:**

National Marine Fisheries Service  
One Blackburn Drive  
Gloucester, Massachusetts 01930  
(978) 281-9300

**Wild and Scenic Rivers:**  
National Park Service  
15 State Street  
Boston, Massachusetts 02109  
(617) 223-5191

**Federal Endangered Species:**  
U.S. Fish and Wildlife Service  
70 Commercial Street, Suite 300  
Concord, New Hampshire 03301  
(603) 223-2541

**Bridge Permits**  
Commander (obr)  
First Coast Guard District  
One South Street - Battery Bldg  
New York, NY 10004  
(212) 668-7021

### 2. STATE OF MASSACHUSETTS

#### **Department of Environmental Protection (DEP):**

DEP Division of Wetlands and Waterways  
One Winter Street  
Boston, Massachusetts 02108  
(617) 292-5695

#### **DEP Regional Offices:**

DEP-Western Regions  
Wetlands Protection Program  
436 Dwight Street  
Springfield, Massachusetts 01103  
(413) 784-1100

DEP-Southeast Region  
Wetlands Protection Program  
20 Riverside Drive, Route 105  
Lakeville, Massachusetts 02347  
(508) 946-2800

DEP-Central Region  
Wetlands Protection Program  
627 Main Street  
Worcester, Massachusetts 01608  
(508) 792-7650

DEP-Northeast Region  
Wetlands Protection Program  
205B Lowell Street  
Wilmington, Massachusetts 01887  
(978) 694-3200

#### **Massachusetts Office of Coastal Zone Management (CZM)**

Coastal Zone Management  
251 Causeway Street, Suite 800  
Boston, Massachusetts 02114  
(617) 626-1200

#### **Massachusetts Board of Underwater Archaeological Resources (BUAR)**

251 Causeway Street, Suite 800  
Boston, Massachusetts 02114  
(617) 626-1141, (617) 626-1240 (fax)  
victor.mastone@state.ma.us

Area of concern: All Massachusetts lakes, ponds, and rivers and coastal waters

### 3. HISTORIC PROPERTIES:

State Historic Preservation Officer (SHPO)  
Massachusetts Historical Commission (MHC)  
The Massachusetts Archives Bldg.  
220 Morrissey Boulevard  
Boston, Massachusetts 02125  
(617) 727-8470  
(617) 727-5128 (fax)  
Area of concern: All of Massachusetts

Wampanoag Tribal Historic Preservation Officer  
Wampanoag Tribe of Gay Head (Aquinnah)  
20 Black Brook Road  
Aquinnah, MA 02535  
(508) 645-9265  
(508) 645-3233 (fax)  
Area of concern: All of Massachusetts

Mashpee Wampanoag Tribe  
Tribal Historic Preservation Authority  
P.O. Box 1048  
Mashpee, Massachusetts 02649  
(508) 419-6017, x601, cgreen@mwtribe.com  
Area of concern: Plymouth, Barnstable & Bristol Counties

Tribal Historic Preservation Officer  
c/o Stockbridge-Munsee Community  
P.O. Box 70  
Bowler, Wisconsin 54416  
(715) 793-3970  
Area of concern: West of Connecticut River

Narragansett Tribal Historic Preservation Officer  
P.O. Box 350  
Wyoming, Rhode Island 02898  
(401) 539-1190 (phone), (401) 862-9158 (cell), (401) 539-4217 (fax), nithpoculturalinfo@cox.net  
Area of concern: Boston and its surrounding neighborhoods; Lynn; Newton; these cities and towns in Plymouth County (Carver, Duxbury, Hingham, Kingston, Marshfield, Middleborough, Plymouth, Plympton, Scituate); these cities and towns in Norfolk County (Milton, Quincy, Braintree, Randolph, Canton, Sharon and Foxborough); and the cities and towns west of Worcester (which are those including and west of Ashburnham, Westminster, Princeton, Holden, Paxton, Leicester, Oxford and Webster).

Massachusetts Board of Underwater Archaeological Resources (BUAR) (see previous page)

### 4. ORGANIZATIONAL WEBSITES:

Army Corps of Engineers  
Environmental Protection Agency  
National Marine Fisheries Service  
U.S. Fish and Wildlife Service  
National Park Service  
Federal Emergency Management Agency  
MA Executive Office of Environmental Affairs  
MA Department of Environmental Protection  
MassDEP, Division of Wetlands  
MassDEP, Division of Waterways  
MA Division of Marine Fisheries  
MA Div. of Fisheries & Wildlife  
MA Endangered Species Program  
MA Coastal Zone Management  
MassGIS  
MA Historical Commission  
MA Board of Underwater Archaeological Resources  
Mashpee Wampanoag Tribe  
Narragansett Tribe  
Stockbridge-Munsee Tribe  
Wampanoag Tribe of Gayhead (Aquinnah)

[www.nae.usace.army.mil/reg](http://www.nae.usace.army.mil/reg)  
[www.epa.gov/owow/wetlands/](http://www.epa.gov/owow/wetlands/)  
[www.nmfs.noaa.gov](http://www.nmfs.noaa.gov)  
[www.fws.gov](http://www.fws.gov)  
[www.nps.gov/rivers/index.html](http://www.nps.gov/rivers/index.html)  
[www.fema.gov](http://www.fema.gov)  
[www.state.ma.us/envir](http://www.state.ma.us/envir)  
[www.state.ma.us/dep](http://www.state.ma.us/dep) (access the four regional offices)  
[www.state.ma.us/dep/brp/ww/rpwwhome.htm](http://www.state.ma.us/dep/brp/ww/rpwwhome.htm)  
[www.state.ma.us/dep/brp/waterway/waterway.htm](http://www.state.ma.us/dep/brp/waterway/waterway.htm)  
[www.state.ma.us/dfwele/dmf/](http://www.state.ma.us/dfwele/dmf/)  
[www.state.ma.us/dfwele/dfw/dfw\\_toc.htm](http://www.state.ma.us/dfwele/dfw/dfw_toc.htm)  
[www.state.ma.us/dfwele/dfw/nhesp/heritage.htm](http://www.state.ma.us/dfwele/dfw/nhesp/heritage.htm)  
[www.state.ma.us/czm](http://www.state.ma.us/czm)  
[www.state.ma.us/mgis/massgis.htm](http://www.state.ma.us/mgis/massgis.htm)  
[www.state.ma.us/sec/mhc](http://www.state.ma.us/sec/mhc)  
[www.mass.gov/czm/buar/index.htm](http://www.mass.gov/czm/buar/index.htm)  
[http://mashpeewampanoagtribe.com](http://http://mashpeewampanoagtribe.com)  
[www.narragansetttribe.com](http://www.narragansetttribe.com)  
[www.mohican.com](http://www.mohican.com)  
[www.wampanoagtribe.net](http://www.wampanoagtribe.net)

## Appendix F: Additional References

### 1. Applying for a Permit, Page 3.

(a) These forms are available at [www.nae.usace.army.mil/reg](http://www.nae.usace.army.mil/reg):

- For the Corps application form, go to “Forms” and then “Application for Department of the Army Permit.”
- For the SHPO/MHC PNF form and guidance, go to “Programmatic General Permits” and then “Massachusetts.”

(b) For the MassDEP’s application forms, go directly to [www.mass.gov/dep/water/approvals/wwforms.htm](http://www.mass.gov/dep/water/approvals/wwforms.htm)

### 2. GC 2: Federal Jurisdictional Boundaries.

(a) Corps Wetlands Delineation Manual, regional supplements, and Corps Wetland Delineation Data Sheets: [www.nae.usace.army.mil/reg](http://www.nae.usace.army.mil/reg) and then “Wetlands and Jurisdictional Limits.”

(b) The USFWS publishes the 1988 National List of Plant Species that Occur in Wetlands ([www.nwi.fws.gov](http://www.nwi.fws.gov)). The Natural Resources Conservation Service (NRCS) publishes the current hydric soil definition, criteria and lists: <http://soils.usda.gov/use/hydric>. For the Field Indicators for Identifying Hydric Soils in N.E., see [www.neiwpsc.org/hydricsoils.asp](http://www.neiwpsc.org/hydricsoils.asp).

### 3. GC 5:

*Single and complete project* means the total project proposed or accomplished by one owner/developer or partnership or other association of owners/developers. For example, if construction of a residential development affects several different areas of a headwater or isolated water, or several different headwaters or isolated waters, the cumulative total of all filled areas should be the basis for deciding whether or not the project will be covered by Category 1 or 2.

The *Independent utility* test is used to determine what constitutes a single and complete project in the Corps regulatory program. A project is considered to have independent utility if it would be constructed absent the construction of other projects in the project area. Portions of a multi-phase project that depend upon other phases of the project do not have independent utility. Phases of a project that would be constructed even if the other phases were not built can be considered as separate single and complete projects with independent utility.

### 4. GC 10: Threatened and Endangered Species.

(a) The following USFWS and NMFS sites must be referenced to ensure that listed species or critical habitat are not present in the action area (GC 10(b)) or to provide information on federally-listed species or habitat (GC 10(c)): [www.fws.gov/newengland/EndangeredSpec-Consultation\\_Project\\_Review.htm](http://www.fws.gov/newengland/EndangeredSpec-Consultation_Project_Review.htm) and [www.nero.noaa.gov/prot\\_res/esp/ListE&Tspec.pdf](http://www.nero.noaa.gov/prot_res/esp/ListE&Tspec.pdf).

(b) The Endangered Species Act Consultation Handbook – Procedures for Conducting Section 7 Consultations and Conferences,” defines action area as “all areas to be affected directly or indirectly by the federal action and not merely the immediate area involved in the action. [50 CFR 402.02].”

### 5. GC 15: Avoidance, Minimization and Compensatory Mitigation.

(a) See Corps website ([www.nae.usace.army.mil/reg](http://www.nae.usace.army.mil/reg)) under “Mitigation” to view the April 10, 2008 “Final Compensatory Mitigation Rule” (33 CFR 332) and related documents. The Q&A document states: “In order to reduce risk and uncertainty and help ensure that the required compensation is provided, the rule establishes a preference hierarchy for mitigation options. The most preferred option is mitigation bank credits, which are usually in place before the activity is permitted. In-lieu fee program credits are second in the preference hierarchy, because they may involve larger, more ecologically valuable compensatory mitigation projects as compared to permittee-responsible mitigation. Permittee-responsible mitigation is the third option, with three possible circumstances: (1) conducted under a watershed approach, (2) on-site and in kind, and (3) off-site/out-of-kind.

(b) In-Lieu fee may be used as compensatory mitigation to protect, benefit and improve marine fish habitat in Massachusetts. See the Massachusetts In-Lieu Fee Mitigation Program Fact Sheet at [www.nae.usace.army.mil/reg](http://www.nae.usace.army.mil/reg) and then “Mitigation.”

(c) Information on minimizing impacts within the vernal pool terrestrial habitat can be found in:

i. Best Development Practices: Conserving pool-breeding amphibians in residential and commercial development in the northeastern U.S., Calhoun and Klemens, 2002. Chapter III, Management Goals and Recommendations, pages 15 - 26, is particularly relevant. (Available for purchase at [www.maineaudubon.org/resource/index.shtml](http://www.maineaudubon.org/resource/index.shtml) and on Corps website\*.)

ii. Science and Conservation of Vernal Pools in Northeastern North America, Calhoun and deMaynadier, 2008. Chapter 12, Conservation Recommendations section, page 241, is particularly relevant. (Available for purchase via the internet. Chapter 12 is available on Corps website\*.)

\* [www.nae.usace.army.mil/reg/index.htm](http://www.nae.usace.army.mil/reg/index.htm) under “Useful Links and Documents.”

**6. GCs 18 and 27: Invasive Species.** Information on preparing an ISCP and what are considered as “invasive species,” is provided in the “New England District Compensatory Mitigation Guidance” at [www.nae.usace.army.mil/reg](http://www.nae.usace.army.mil/reg) under “Mitigation.” The June 2009 “Corps of Engineers Invasive Species Policy” is under “Invasive Species” and provides policy, goals and objectives.

**7. GC 20: Bank Stabilization.** This generally eliminates bodies of water where the reflected wave energy may interfere with or impact on harbors, marinas, or other developed shore areas. A revetment is sloped and is typically employed to absorb the direct impact of waves more effectively than a vertical seawall. It typically has a less adverse effect on the beach in front of it, abutting properties and wildlife. See the Corps Coastal Engineering Manual [EM 1110-2-1100](http://www.nae.usace.army.mil) at [www.nae.usace.army.mil](http://www.nae.usace.army.mil) under “Useful Links and Documents” for design and construction guidance.

**8. GC 21: Stream Crossings and Work.**

(a) The version of the “Massachusetts River and Stream Crossing Standards” that must be used to comply with this GP is provided on our website ([www.nae.usace.army.mil/reg](http://www.nae.usace.army.mil/reg)) under “Stream and River Continuity.”

(b) Projects should be designed and constructed to ensure long-term success using the most recent manual located at [www.nae.usace.army.mil/reg](http://www.nae.usace.army.mil/reg) under “Stream and River Continuity,” currently “Stream Simulation: An Ecological Approach to Providing Passage for Aquatic Organisms at Road-Stream Crossings, by the U.S. Forest Service.” Section 5.3.3 is of particular importance. Sections 7.5.2.3 Construction Methods and 8.2.11 Stream-Simulation Bed Material Placement both show important steps in the project construction.

(c) The Massachusetts Dam Removal and the Wetland Regulations guidance may be used to evaluate the positive and negative impacts of culvert replacement, including the loss of upstream wetlands which may be offset by the overall benefits of the river restoration. See [www.nae.usace.army.mil/reg](http://www.nae.usace.army.mil/reg) and then “Stream and River Continuity.”

(d) GC 21(i): The Skidder Bridge Fact Sheet at [www.nae.usace.army.mil/reg](http://www.nae.usace.army.mil/reg) under “Stream and River Continuity” may be a useful temporary span construction method.

**9. GC 22: Wetland Crossings.** The MassDEP’s crossing standards are at 310 CMR 10.53(3)(e).

**10. GC 24: Spawning, Breeding and Migratory Areas.** The MA DMF “Marine Fisheries Time of Year (TOY) Restrictions for Coastal Alteration Projects” document is located at [www.nae.usace.army.mil/reg](http://www.nae.usace.army.mil/reg), under “State General Permits,” and then under “Massachusetts.”

**11. GC 29: Maintenance.** River restoration projects that are designed to accommodate the natural dynamic tendencies of the fluvial system are maintained in accordance with the project’s design objectives (Category 1) or the Corps authorization letter (Category 2). These projects are generally designed to support and implement channel assessment and management practices that recognize a stream’s natural dynamic tendencies.

**12. Appendix A.** The DEP’s “A Guide to Permitting Small, Pile-Supported Docks and Piers” is located at [www.mass.gov/dep/water/resources/smaldock.pdf](http://www.mass.gov/dep/water/resources/smaldock.pdf)

## Appendix G: Wild and Scenic Rivers

The Corps will consult with the National Park Service (NPS) with regard to potential impacts of the proposed work on the resource values of the wild and scenic river. The culmination of this coordination will be a determination by the NPS and the Corps that the work: (1) may proceed as proposed; (2) may proceed with recommended conditions; or (3) could pose a direct and adverse effect on the resource values of the river and an Individual Permit is required. If preapplication consultation between the applicant and the NPS has occurred whereby NPS has made a determination that the proposed project is appropriate for authorization under this GP (with respect to Wild and Scenic River issues), this determination should be furnished to the Corps with submission of the application.

National Wild and Scenic Rivers System segments for Massachusetts as of April 2009 include:

**Sudbury/Assabet/Concord Rivers:** the Sudbury from the Danforth Street bridge in Framingham downstream to the confluence with the Assabet, the Assabet from 1,000 feet below the Damon Mill Dam downstream to the confluence with the Sudbury, and the Concord from the confluence of the Sudbury and Assabet downstream to the Route 3 bridge in Billerica.

**Westfield River:** Shaker Mill Brook from Brooker Hill Road in Becket to its headwaters. The Upper East Branch from the Windsor/Cummington town line to its confluence; Upper East Branch Tributaries including Drowned Land Brook, Center Brook and Windsor Jambs Brook. Headwater tributaries of the West Branch, including Shaker Mill Brook from Brooker Hill Road in Becket to its confluence with the West Branch; Depot Brook; Savery Brook; Watson Brook; and Center Pond Brook from Center Pond to its confluence with the West Branch. The Lower Middle Branch, East Branch, and Main Stem in the Town of Huntington (3.2 miles) and the Upper East Branch from its confluence with Sykes Brook to its confluence with the West Branch.

**Taunton River:** From the confluence of the Town River and Matfield River in Bridgewater downstream to Mt. Hope Bay at the Rte 195 bridge in Fall River.

## Appendix H: Essential Fish Habitat (EFH)

As part of the application review process, the Corps will coordinate with NMFS in accordance with the 1996 amendments to the Magnuson-Stevens Fishery and Conservation Management Act to protect and conserve the habitat of marine, estuarine and anadromous finfish, mollusks, and crustaceans. This habitat is termed “Essential Fish Habitat” (EFH), and is broadly defined to include “those waters and substrate necessary to fish for spawning, breeding, feeding, or growth to maturity.” For additional EFH information and/or locations, contact NMFS (see Appendix E), or go to [www.nmfs.noaa.gov](http://www.nmfs.noaa.gov) (50 CFR 600) or [www.nero.nmfs.gov/RO/DOC/appguide1.html](http://www.nero.nmfs.gov/RO/DOC/appguide1.html).

The following streams are stocked with Atlantic salmon (*Salmo salar*). Note that the mainstems of the Connecticut and Merrimack Rivers are navigable waters of the U.S. and any fill in them must be reviewed under Category 2. Any questions on locations should be directed to the Corps.

### **Connecticut River Watershed**

Agawam:	Westfield River
Ashfield:	Bear River, South River to Baptist Corner Road
Athol:	Millers River
Becket:	Depot Brook, Shaker Mill Brook, Walker Brook to Spark Brook, West Branch Westfield River, Yokum Brook to Rudd Pond Brook
Bernardston:	Fall River
Blandford:	Wigwam Brook
Buckland:	Deerfield River
Charlemont:	Chickley River, Cold River, Deerfield to Pelham Brook, North River, Pelham Brook
Chester:	Middle Branch Westfield River, Walker Brook, West Branch Westfield River
Chesterfield:	Child’s Brook West Branch, Dead Branch, Tower Brook, Westfield River
Colrain:	North River, East Branch North River, West Branch North River, Green River
Conway:	Bear River, Deerfield River, Poland Brook, South River
Cummington:	Bartlett Brook, Child’s Brook West Branch, Meadow Brook, North Branch Swift River to Stage Road, Swift River, Westfield Brook, Westfield River
Deerfield:	Deerfield River
Easthampton:	Manhan River to North Branch Manhan River, North Branch Manhan River
Erving:	Millers River
Florida:	Cold River
Gill:	Fall River
Goshen:	Swift River
Greenfield:	Allen Brook, Deerfield River, Fall River, Green River
Hatfield:	Mill River to West Brook, West Brook
Hawley:	Chickley River to King Brook, Mill Brook to Gorge Hill Road
Huntington:	Dead Branch to Westfield River, Little River, Middle Branch Westfield River, Pond Brook to Searle Road, Roaring Brook to Mica Mill Road, West Branch Westfield River, Westfield River
Leverett:	Sawmill River
Leyden:	Green River
Middlefield:	Factory Brook, Middle Branch Westfield River to Tuttle Brook, West Branch Westfield River
Montague:	Millers River, Sawmill River
Montgomery:	Westfield River, Roaring Brook
Northampton:	North Branch Manhan River
Orange:	Millers River
Plainfield:	Bartlett Brook to Prospect Street, Meadow Brook to Gloyd Street
Rome:	Pelham Brook to Rice Brook

Royalston: Millers River to Birch Hill Dam  
Russell: Bradley Brook, Potash Brook, Stage Brook, Westfield River  
Savoy: Cold River to Black Brook, Westfield River to Griffin Hill Road  
Shelburne: Allen Brook, Deerfield River, North River  
Shutesbury: Sawmill River  
Southampton: North Branch Manhan River  
Southwick: Munn Brook  
Washington: Depot Brook to Frost Road  
Wendell: Millers River  
Westfield: Little River to Munn Brook, Moose Meadow Brook to Mass Turnpike, Munn Brook, Westfield River  
Westhampton: Dead Branch, North Branch Manhan River to Northwest Road  
West Springfield: Westfield River  
Whately: West Brook to Haydenville Road  
Windsor: Westfield Brook to East Windsor Road, Westfield River  
Worthington: Bronson Brook, Child's Brook West Branch, Little River to Goss Hill Road, Middle Branch  
Westfield River to Tuttle Brook

**Merrimack River Watershed**

Pepperell: Nissitissit River to Nashua River, Nashua River from Nissitissit River to  
New Hampshire border



## Appendix K: Aquaculture Guidelines

NOTE: The following guidelines are excerpted from the Corps Aquaculture Letter of Permission dated September 1, 1991, with some modern clarifications.

Shellfish Aquacultural Facilities are used for bottom and/or suspended culturing and harvesting of bivalve mollusks in the inter-tidal and immediate sub-tidal area of navigable waters. Activities covered include: deployment and maintenance of buoys, rafts, trays, lines, and other equipment associated with the activity; discharge of minor quantities of fill material (i.e. as mineral growth medium) and work, including seed placement, transplanting, temporary wet storage, and harvesting. Activity must be found to have minimal impacts on navigation and the environment and must meet the following specific criteria:

1. The area authorized for this activity shall not exceed 10 acres, except where the permittee is a duly authorized municipality, for which the maximum size shall be 25 acres.
2. The area and any elevated structures within it are marked in conformance with 33 CFR 64, and the permittee has contacted the U.S. Coast Guard, *First District*, Aids to Navigation Branch (617) 223-8347, to coordinate the proper buoy markings for the activity. Buoys shall be deployed and maintained as appropriate.
3. Rafts and other floating equipment may be allowed to the extent that they cover no more than 10% of the project area, or 20,000 square feet, whichever is greater. An area shall be considered to be covered with floating equipment if normal navigation through the area is precluded. Projects which are in-place and authorized by the municipality (and MA Division of Marine Fisheries if applicable) *by 1 September 1991* which have areas containing floating equipment exceeding the aforementioned limits may be authorized if they meet the remaining criteria. All rafts shall be securely anchored to the bottom, and all "lines" shall be attached to fixed mooring points at both ends.
4. Any fill material imported to the project from off site (*this is limited to mineral growth medium used in culture trays*) shall be clean and of comparable grain size to the native substrate.
5. No activity shall occur within a distance of 25 feet from beds of eelgrass, widgeongrass, or saltmarsh, nor shall such vegetation be damaged or removed.
6. An activity shall be deemed not applicable under this GP if it can be shown that the activity, including any vehicular access, will have more than minimal negative impacts on avian resources such as, but not limited to: shore birds, wading birds, or members of the waterfowl group. This is meant to include migratory bird nesting, feeding or resting activities (see 50 CFR 10.13).
7. An activity shall be deemed not applicable under this GP if it can be shown that the activity, including any vehicular access, will have more than minimal negative impacts on existing or naturally occurring beds or population of shellfish, marine worms or other invertebrates that could be used by humans, other mammals, birds, reptiles, or predatory fish.
8. No activity nor vehicular access to an activity shall occur in such a way as to negatively impact coastal or freshwater wetlands, or any endangered or threatened species on either the federal or Massachusetts species list.
9. Aquaculture applicants do not need to notify the SHPO/MHC as stated in the application procedures on Page 3 of this document since these projects are unlikely to affect historic or archaeological resources. However the BUAR and four tribes do require notification.

[Intentionally Left Blank]

## **Appendix D**

**US Army Corps of Engineers  
Massachusetts Department of Transportation  
Comprehensive Permit for Bridges**





DEVAL L. PATRICK, GOVERNOR  
TIMOTHY P. MURRAY, LT. GOVERNOR  
JEFFREY B. MULLAN, SECRETARY & CEO  
LUIA PAIEWONSKY, ADMINISTRATOR



August 6, 2010

Robert J. DeSista  
Chief, Regulatory Division  
Department of the Army  
New England District, Corps of Engineers  
696 Virginia Road  
Concord, MA 01742

**RE: Comprehensive Permit for Bridges**

Dear Mr. DeSista:

The Massachusetts Department of Transportation Highway Division has reviewed the Comprehensive Permit for Bridges (CPB). Please find attached a signed copy of the permit. As discussed on 7/30/2010 with Karen K. Adams, Army Corps Regulatory Division, and MassDOT's Environmental Section, we accept the permit terms, on the condition that three elements be amended as follows:

- Activities involving work to Army Corps Flood Control/Protection Projects are not eligible for the CPB.
- The sole presence of a Historic District will not exclude a project from the CPB.
- Dredge/excavation activities not subject to Army Corps jurisdiction will not exclude a project from the CPB.

If you have any questions regarding this letter, please contact Henry Barbaro, Wetlands/Water Resources Supervisor, Environmental Section, MassDOT Highway Division, at (617) 973-7419.

Sincerely,

Frank Tramontozzi, P.E.  
Chief Engineer  
Highway Division  
Massachusetts Department of Transportation

Attachments: one complete, signed copy of the Comprehensive Permit for Bridges



REPLY TO  
ATTENTION OF

**DEPARTMENT OF THE ARMY**  
NEW ENGLAND DISTRICT, CORPS OF ENGINEERS  
696 VIRGINIA ROAD  
CONCORD, MASSACHUSETTS 01742-2751

July 20, 2010

Regulatory Division  
CENAE-R  
Permit Number: NAE-2008-3745

Frank Tramontozzi, P.E.  
Massachusetts Dept of Transportation  
10 Park Plaza  
Boston, MA 02116

Dear Mr Tramontozzi:

Attached are two copies of a Department of the Army permit authorizing the work described therein. Your signature is necessary to execute this permit. The authorized work cannot start until we receive a complete, signed copy of the permit. If the conditions are acceptable, please sign both copies and return one signed copy of the entire permit to "Regulatory Division" at the address above.

This permit is a limited authorization containing a specific set of conditions. Please read the permit thoroughly to familiarize yourself with those conditions, including any conditions contained on the attached state water quality certification. If a contractor does the work for you, both you and the contractor are responsible for ensuring that the work is done in compliance with the permit's terms and conditions, as any violations could result in civil or criminal penalties.

The Corps of Engineers has consulted with the National Marine Fisheries Service (NMFS) regarding the effects of your project on Essential Fish Habitat (EFH) designated under the Magnuson-Stevens Fishery Conservation and Management Act. The NMFS provided EFH conservation recommendations, which we included in the attached special conditions.

This letter contains a proffered permit for your proposed project. If you object to this decision, you may request an administrative appeal under Corps regulations at 33 CFR 331. A combined Notification of Administrative Appeal Options and Process (NAP) and Request for Appeal (RFA) form, and flow chart explaining the appeals process and your options, are attached to this letter. If you desire to appeal this determination, you must submit a completed RFA form along with any supporting or clarifying information to Michael G. Vissichelli, Administrative Appeals Review Officer, North Atlantic Division, Corps of Engineers, North Atlantic Fort Hamilton Military Community, Bldg. 301, General Lee Avenue, Brooklyn, NY 11252-6700. Contact information: (718) 765-7163 or michael.g.vissichelli@usace.army.mil.

In order for an RFA to be accepted by the Corps, the Corps must determine that it is complete, that it meets the criteria for appeal under 33 CFR 331.5, and that it has been received by the Division Office within 60 days of the date of the NAP.

You may not appeal conditions contained in the State water quality certification or the CZM consistency determination under this program as they are automatically included in the Federal permit. Also note that the Department of the Army permit process does not supersede any other agency's jurisdiction.

We continually strive to improve our customer service. In order for us to better serve you, we would appreciate your completing our Customer Service Survey located at <http://per2.nwp.usace.army.mil/survey.html>

If you have any questions regarding this correspondence, please contact Karen K. Adams at (978) 318-8828, (800) 343-4789, or use (800) 363-4367 within Massachusetts.

Sincerely,

A handwritten signature in blue ink, appearing to read "Robert J. DeSista".

Robert J. DeSista  
Chief, Regulatory Division

Attachments

---

DEPARTMENT OF THE ARMY PERMIT

Permittee Massachusetts Department of Transportation

Permit No. NAE-2008-3745

Issuing Office New England District

NOTE: The term "you" and its derivatives, as used in this permit, means the permittee or any future transferee. The term "this office" refers to the appropriate district or division office of the Corps of Engineers having jurisdiction over the permitted activity or the appropriate official of that office acting under the authority of the commanding officer.

You are authorized to perform work in accordance with the terms and conditions specified below.

**Project Description:**

The work authorized includes the placement of fill material in wetlands and waterways necessary for the replacement, reconstruction, rehabilitation and maintenance of public bridges throughout the Commonwealth of Massachusetts in accordance with the attached "Standards and Conditions for the Comprehensive Permit for Bridges" dated "6-11-2010".

**Project Location:**

Wetlands and waterways in Massachusetts

**Permit Conditions:**

**General Conditions:**

1. The time limit for completing the work authorized ends on July 31, 2015. If you find that you need more time to complete the authorized activity, submit your request for a time extension to this office for consideration at least one month before the above date is reached.
2. You must maintain the activity authorized by this permit in good condition and in conformance with the terms and conditions of this permit. You are not relieved of this requirement if you abandon the permitted activity, although you may make a good faith transfer to a third party in compliance with General Condition 4 below. Should you wish to cease to maintain the authorized activity or should you desire to abandon it without a good faith transfer, you must obtain a modification of this permit from this office, which may require restoration of the area.
3. If you discover any previously unknown historic or archeological remains while accomplishing the activity authorized by this permit, you must immediately notify this office of what you have found. We will initiate the Federal and state coordination required to determine if the remains warrant a recovery effort or if the site is eligible for listing in the National Register of Historic Places.



4. If you sell the property associated with this permit, you must obtain the signature of the new owner in the space provided and forward a copy of the permit to this office to validate the transfer of this authorization.

5. If a conditioned water quality certification has been issued for your project, you must comply with the conditions specified in the certification as special conditions to this permit. For your convenience, a copy of the certification is attached if it contains such conditions.

6. You must allow representatives from this office to inspect the authorized activity at any time deemed necessary to ensure that it is being or has been accomplished in accordance with the terms and conditions of your permit.

**Special Conditions:**

1. The permittee shall ensure that a copy of this permit is at the work site whenever work is being performed and that all personnel performing work at the site of the work authorized by this permit are fully aware of the terms and conditions of the permit. This permit, including its drawings and any appendices and other attachments, shall be made a part of any and all contracts and sub-contracts for work which affects areas of Corps of Engineers jurisdiction at the site of the work authorized by this permit. This shall be done by including the entire permit in the specifications for work.

**(Special Conditions continued on Page 4)**

**Further Information:**

1. **Congressional Authorities:** You have been authorized to undertake the activity described above pursuant to:

Section 10 of the Rivers and Harbors Act of 1899 (33 U.S.C. 403).

Section 404 of the Clean Water Act (33 U.S.C. 1344).

Section 103 of the Marine Protection, Research and Sanctuaries Act of 1972 (33 U.S.C. 1413).

2. **Limits of this authorization.**

a. This permit does not obviate the need to obtain other Federal, state, or local authorizations required by law.

b. This permit does not grant any property rights or exclusive privileges.

c. This permit does not authorize any injury to the property or rights of others.

d. This permit does not authorize interference with any existing or proposed Federal project.

3. **Limits of Federal Liability.** In issuing this permit, the Federal Government does not assume any liability for the following:

a. Damages to the permitted project or uses thereof as a result of other permitted or unpermitted activities or from natural causes.

b. Damages to the permitted project or uses thereof as a result of current or future activities undertaken by or on behalf of the United States in the public interest.

c. Damages to persons, property, or to other permitted or unpermitted activities or structures caused by the activity authorized by this permit.

d. Design or construction deficiencies associated with the permitted work.

- e. Damage claims associated with any future modification, suspension, or revocation of this permit.
4. **Reliance on Applicant's Data:** The determination of this office that issuance of this permit is not contrary to the public interest was made in reliance on the information you provided.
5. **Reevaluation of Permit Decision.** This office may reevaluate its decision on this permit at any time the circumstances warrant. Circumstances that could require a reevaluation include, but are not limited to, the following:
- a. You fail to comply with the terms and conditions of this permit.
  - b. The information provided by you in support of your permit application proves to have been false, incomplete, or inaccurate (See 4 above).
  - c. Significant new information surfaces which this office did not consider in reaching the original public interest decision.

Such a reevaluation may result in a determination that it is appropriate to use the suspension, modification, and revocation procedures contained in 33 CFR 325.7 or enforcement procedures such as those contained in 33 CFR 326.4 and 326.5. The referenced enforcement procedures provide for the issuance of an administrative order requiring you to comply with the terms and conditions of your permit and for the initiation of legal action where appropriate. You will be required to pay for any corrective measures ordered by this office, and if you fail to comply with such directive, this office may in certain situations (such as those specified in 33 CFR 209.170) accomplish the corrective measures by contract or otherwise and bill you for the cost.

6. **Extensions.** General condition 1 establishes a time limit for the completion of the activity authorized by this permit. Unless there are circumstances requiring either a prompt completion of the authorized activity or a reevaluation of the public interest decision, the Corps will normally give favorable consideration to a request for an extension of this time limit.

Your signature below, as permittee, indicates that you accept and agree to comply with the terms and conditions of this permit.

      8/6/2010  
 (PERMITTEE)      (DATE)

This permit becomes effective when the Federal official, designated to act for the Secretary of the Army, has signed below.

      7/19/10  
 (DISTRICT ENGINEER)      (DATE)

**Philip T. Feir**  
 Colonel, Corps of Engineers

When the structures or work authorized by this permit are still in existence at the time the property is transferred, the terms and conditions of this permit will continue to be binding on the new owner(s) of the property. To validate the transfer of this permit and the associated liabilities associated with compliance with its terms and conditions, have the transferee sign and date below.

\_\_\_\_\_      \_\_\_\_\_  
 (TRANSFEE)      (DATE)

(Special Conditions continued from Page 2)

If the permit is issued after the construction specifications but before receipt of bids or quotes, the entire permit shall be included as an addendum to the specifications. If the permit is issued after receipt of bids or quotes, the entire permit shall be included in the contract or sub-contract as a change order. The term "entire permit" includes permit amendments. Although the permittee may assign various aspects of the work to different contractors or sub-contractors, all contractors and sub-contractors shall be obligated by contract to comply with all environmental protection provisions of the entire permit, and no contract or sub-contract shall require or allow unauthorized work in areas of Corps jurisdiction.

2. Work shall be performed in accordance with the attached "Standards and Conditions for the Comprehensive Permit for Bridges" dated "6-11-2010".
3. The permittee shall provide to the Corps a work start notification form (Attachment 4) prior to the start of work being undertaken under this authorization.
4. The permittee shall notify the Corps immediately of any incidents of non-compliance with this permit. The proposed resolution and schedule for bringing the work into compliance should be provided as soon as available.
5. The permittee shall provide to the Corps and National Marine Fisheries Service an annual report with a list of projects completed under this permit, their location, the amount of resulting temporary and permanent wetland impact, the best management practices employed to avoid and minimize adverse effects, and the amount of compensatory mitigation successfully completed.
6. Except where stated otherwise, reports, drawings, correspondence and any other submittals required by this permit shall be marked with the words "Permit No. NAE-2008-3745" and shall be addressed to "Chief, Permits Branch (MA), Regulatory Division, U.S. Army Corps of Engineers, 696 Virginia Road, Concord, MA 01742-2751." Documents which are not marked and addressed in this manner may not reach their intended destination and do not comply with the requirements of this permit.
7. The permittee understands and agrees that, if future operations by the United States require the removal, relocation, or other alteration, of the structure or work herein authorized, or if, in the opinion of the Secretary of the Army or his authorized representative, said structure or work shall cause unreasonable obstruction to the free navigation of the navigable waters, the permittee will be required, upon due notice from the Corps of Engineers, to remove, relocate, or alter the structural work or obstructions caused thereby, without expense to the United States. No claim shall be made against the United States on account of any such removal or alteration.
8. The permittee shall not interfere with Corps of Engineers personnel or its contractors engaged in hydrographic surveys, maintenance or improvement of any Federal Navigation Project (FNP). If, in the opinion of the Corps, the permittee's structures or vessels attached to them must be moved to allow for the maintenance or improvement of the existing FNP, the permittee shall move the structures or vessels as directed by the Corps.
9. Work associated with this permit shall not affect the depth or width of the Federal Navigation Project (FNP). Following construction, any material, machinery or equipment lost, dumped, thrown into, or otherwise entering the waterway shall be removed immediately or as soon as possible. If immediate removal is impractical and the object entering the waterway is or could become an obstruction or hazard

to navigation, the object shall be marked immediately to protect navigation and the Coast Guard shall be notified immediately.

10. For projects located within the areas of concern to the Narragansett Tribe, the Massachusetts Historic Commission "Project Notification Form" and a locus map with the project boundaries clearly located shall be submitted to the Tribal Historic Preservation Office of the Narragansett Tribe early in the project review to request their input on the scoping of any archeological investigations and review for the presence of historic, archaeological, or tribal resources in the permit area that the proposed work may affect. The areas of concern to the Narragansett Tribe are the town clusters of:

- 1) Westborough, Hopkinton, Milford, Franklin, Hopedale, Mendon, Holliston, Blackstone, Millville, Uxbridge, Upton, Grafton, Millbury.
- 2) North Attleborough, Attleboro, Seekonk, Dighton, Taunton, Berkley, Lakeville, Freetown, Fall River, Mattapoissett.
- 3) Harvard, Stow, Ayer, Acton, Concord, Carlisle, Boxborough, Littleton, Maynard.
- 4) Salisbury, Merrimac, Amesbury, Newburyport, West Newbury, Haverhill, Newbury, Groveland, Dracut, Lowell, Rowley, Ipswich.
- 5) the regional valley corridors of the navigable waters of the Commonwealth and their tributaries including the Connecticut River, Millers River, Deerfield, Green River, North River, Hoosic River, Housatonic River, Westfield River, Merrimac River, the Blackstone River, Concord River, Sudbury River, Assabet River, Taunton River, Nemasket River, Quabbin Reservoir, Wachusett Reservoir, Assawomsett Pond, Watuppa Pond.
- 6) Areas west of Worcester including, and west of, Ashburnham and Westminster. Princeton, Holden, Paxton, Leicester, Oxford and Webster.
- 7) Boston including its neighborhoods, and Lynn and Newton.
- 8) the towns of Carver, Duxbury, Hingham, Kingston, Marshfield, Middleborough, Plymouth, Plympton, Scituate, Milton, Quincy, Braintree, Randolph, Canton, Sharon and Foxborough.

## **Standards and Conditions for the Comprehensive Permit for Bridges**

### *Project Eligibility*

Certain projects, depending on federal requirements or the environmental sensitivity of the area, will not be eligible for authorization under this permit. Projects not eligible include:

- More than 5,000 square feet of impact to vegetated wetlands or waters,
- Bridges crossing a Federally-designated Wild and Scenic River;
- Projects involving work on Corps properties and Corps-controlled flood easements such as the Charles River Natural Valley Storage Area;
- Proposed bridge replacements where the low chord will intersect the 10-year flood elevation;
- Bridges that have been identified by the Massachusetts Office of Coastal Zone Management as potentially causing restrictions to tidal flows.
- Projects which may affect any federally listed endangered species or their habitat.
- Any project located in an historic district or where there may be an effect to any National Register eligible property unless impacts have been addressed pursuant to the Programmatic Agreement (PA) between Federal Highway Administration and the State Historic Preservation Officer or any subsequent Corps of Engineers PA to satisfy the requirements of Section 106 of the National Historic Preservation Act.
- For a bridge span or arch:
  - The proposed open span waterway width at ground level is less than the existing structure's span. However, this qualification does not apply if the new span width is at least 1.2 times the geomorphic bank full width of the stream.
  - The proposed bridge span or arch span constricts flow over a bedrock dominated streambed, resulting in impassable stream flow velocities.
  - There is a dam or other structural element (other than a bridge abutment or pier) that obstructs the channel within the footprint of the proposed bridge span or arch span.
  - A proposed "bridge" that consists of a culvert that is rated as a moderate or severe barrier to aquatic organism passage. A moderate or severe barrier is a structure with a Crossing Rating of less than 3, based on an evaluation using the "MassDOT Stream Crossing Structures Rating Chart" in Attachment 3.

These projects will be reviewed through the existing Massachusetts General Permit or Standard (Individual) Permit process. All bridge projects will continue to be reviewed pursuant to the Section 401 Water Quality Certification program, administered by the Massachusetts Department of Environmental Protection (MA DEP), which is the counterpart of the USACE Section 404 permit process. These bridge projects will adhere to the General Conditions (as amended) found in the Attachment 1 MA DEP Water Quality Certification Standard Form (WQC-SF) for MassDOT Bridge Replacement and Rehabilitation Projects.

### *Wildlife Considerations*

Bridge projects within Massachusetts Priority Habitat of Rare Species or Estimated Habitat of Rare Wildlife, as determined by mapping compiled by the Massachusetts Division of Fisheries and Wildlife Natural Heritage and Endangered Species Program (MNHESP), are eligible provided that the project has been reviewed and received a determination of no adverse effect from the MNHESP. MassDOT will coordinate and obtain written concurrence from National Marine Fisheries Service prior to any blasting within Essential Fish Habitat.

### *Considerations for a Bridge's Hydraulic Opening*

The waterway openings of all bridges eligible for authorization under this permit will be designed to provide a degree of flood conveyance that conforms to applicable floodplain development performance standards of the National Flood Insurance Program (NFIP) (see 44 CFR 60.3). This design approach assures that all bridge replacement projects authorized by this permit comply with Executive Order 11988 (EO 11988), Floodplain Management. If the hydraulic study performed for a bridge in either SFHA Zone A, AE or AE w/floodway indicates that the implementation of the replacement bridge opening will result in an altered base flood elevation profile near the bridge location, and no practical remediation to the project's expected base flood elevation profile alteration impact can be achieved the project will not be eligible for this authorization. Additionally, if the low chord elevation of a proposed bridge is less than the crossed waterway's upstream 10-year flood elevation, it will not be eligible for this authorization.

### *Water Control Measures for Bridge Projects*

Repair work on bridge abutments and piers typically must be done in the dry. The work area must be suitably contained to minimize impacts to waterways. This is accomplished by creating a dry work area through the use of an appropriate type of water control measures, as described in Table 1 below and as depicted on the accompanying Figures 1-8 in Attachment 2. By isolating the work area, these water control methods alleviate pollution during construction operations, thereby protecting the interests of the Section 404 regulations.

Construction techniques and water control measures that can be used to minimize impacts to waters and EFH habitat include use of cofferdams to isolate the work areas, flume pipes, dewatering measures to remove turbidity from water before run back, and equipment and cofferdam removal techniques to minimize filling or generation of turbidity. Turbidity curtains or booms may also be used to help contain any fugitive turbidity. Care must be used in the deployment of curtains as curtains will not be deployed across flowing water.

Authorized water control methods include:

- Sandbag Cofferdam (Figure 1);
- Section Concrete or Jersey Barrier Cofferdam (Figure 2);
- Steel, Wood or Vinyl Sheeting Cofferdam (Figure 3);
- Coated Fabric and Steel Frame Cofferdam, e.g., Portadam (Figure 4); and
- Flume Pipe (Figure 5)
- Depending on the characteristics of the project work site, or the preferences of the contractor, other water control methods may be used. MassDOT will coordinate and obtain written concurrence from National Marine Fisheries Service (NMFS) prior to use of any other type of water control measure within Essential Fish Habitat.

Dewatering (pump out) of the work area is authorized to an established upland sedimentation basin, or other approved sediment removal device, in order to perform the required bridge work under dry conditions. Any required long-term scour protection, e.g., placement of riprap around an abutment or pier (Figure 2), will occur prior to cofferdam removal. Two dewatering/sediment control methods include:

- Hay/Straw Bale Barrier enclosure (Figure 6); and
- Filter Bag (Figure 7).

During removal of the cofferdam or other approved water control measure, if sufficient water depth exists, a turbidity curtain/boom (Figure 8) will be placed outside the cofferdam and used to minimize sedimentation entering the stream flow during cofferdam removal. Cofferdam removal is performed downstream-to- upstream in a manner that minimizes introduction of sediment to the waterway.

Table 1 – Water Control Measures

Water Control Measure	Conditions for Use
Flume/Diversion Pipe (Where entire water column must be isolated and protected)	Will need some form of diversion or dam to direct flows through the pipe. Flume pipe must be installed level with stream bed to prevent blocking fish movement. Stream bed must be stabilized at outlet.
Cofferdam Options (Where entire or partial channel must be isolated and de-watered) Sand bags with polyethylene plastic sheeting Sheet pile (steel, wood or vinyl) Coated fabric and steel frame, e.g., Portadam Water tube Sectional concrete barrier (e.g., Jersey Barrier) with polyethylene plastic sheeting and sand bags at joints and to secure plastic sheeting,	To the greatest extent practicable, all in-stream work, i.e., installation and removal of cofferdams, should be conducted during low flow periods throughout the year. Times of year when stream flow is high due to extended rain and/or melt water events should be avoided. Must stabilize work area prior to cofferdam removal compatible with streambed characteristics (crushed stone, biodegradable erosion control matting). Remove cofferdam downstream to upstream.

Unacceptable water control measures:

- Turbidity curtains across flow
- Earthen embankments
- Diversion channels
- Bypass pumping

To ensure that the work will not adversely impact fish passage no more than 50% of the channel can be blocked during construction. Projects are not eligible if more than 50% will be blocked.

*Construction Timing*

Timing of the construction activities may have an impact on aquatic resources and Essential Fish Habitat (EFH). To the extent possible, in-water construction will be timed to avoid high flow conditions and sensitive fish migration or breeding periods. If cofferdams are used, once installed, work may proceed without consideration of flow conditions, fish migration or breeding concerns since the work area will be isolated from the waterway or water body. Removal of any in-water features will also be timed to the extent possible to avoid high flow or biologically active time periods. However, removal of equipment or cofferdams may proceed at any time, provided adequate safeguards are used to avoid excessive impact to the waterway or water body. Removal of in-stream construction features in a timely manner will reduce the duration of any temporary impacts and allow the project area to recover more quickly. No sediment producing in water work will occur in EFH in the Connecticut River watershed between April 1-July 15 to protect downstream migration of Atlantic salmon smolts; as well as September 1 - October 31 to protect upstream migration of adult salmon unless MassDOT coordinates with and obtains written concurrence from NMFS. For any work within coastal zone rivers, and the Merrimack and Connecticut Rivers, MassDOT will coordinate with Massachusetts Division of Marine Fisheries (and reference the DMF Time of Year report <http://www.nae.usace.army.mil/reg/index.htm>) to obtain any applicable time of year restrictions and concurrence on other construction mitigation techniques for all work in waterways. MassDOT will seek similar coordination with the Massachusetts Division of Fisheries and Wildlife for any river work in other areas.

*Construction Sequence*

Temporary and permanent impacts from bridge projects can be minimized by construction sequencing. Construction activities will be sequenced to avoid work within the entire waterway or along the entire crossing at the same time. Multiple-span bridges will be repaired while keeping one or more spans fully open to allow unimpeded flow and movement of fish. As construction progresses, work will move to other spans or piers and flow will be restored to the completed portions of the bridge. In this way, flow and migration pathways will be maintained throughout the construction period.



Another feature of construction sequencing will be to avoid in-water work to the extent possible during high flow conditions. Construction activities on approach roadways, the bridge deck or other non-wetland areas will be scheduled to the extent possible during high flows or sensitive migratory and breeding periods.

### *Wetland Replacement and Restoration*

Bridge repair and reconstruction, in particular abutment and approach roadway work, may result in a permanent loss of wetland habitat and flood storage. Any permanent impact to vegetative wetlands and/or flood storage must be mitigated by replacement in kind at a 1:1 ratio. Any project that includes a permanent impact to vegetated wetland habitat will include measures to replace the lost wetland area. Generally, a nearby upland area adjacent to existing wetlands will be excavated, graded, and planted to replace the lost functions. Temporary impacts to vegetated wetlands from wall construction, grading, or necessary access will be restored to preconstruction conditions. Removal of any temporary fill, regrading to restore preconstruction contours, and replanting with native wetland species will be conducted to ensure no long term loss of habitat. All construction work areas will be restored and stabilized to prevent erosion to the adjacent wetland resources.

---

### *Riprap Gradation*

Stone riprap placed for scour protection shall at a minimum conform to the Specifications set forth in Standard Specifications for Highways and Bridges, Massachusetts Highway Department, 1988. Section M2.02.2. Heavier stone riprap may be used as needed to minimize displacement and damage due to vandalism, foot traffic, and ice and water movement.

The post-construction elevation of any scour protection shall be the same as, or slightly lower than, the pre-construction natural, river bed profile. The river bed, therefore, may have to be excavated so that the elevation of the top of the stone placed for scour protection is not higher than the adjacent river bed profile. In addition, the post-construction river bed elevation shall match upstream and downstream river bed elevations. Artificially high sediment deposits may exist under a bridge due to road drainage, run-off, and/or the effects of the bridge abutments and piers on stream flow. Artificially high stream deposits may need to be removed to restore channel capacity and should not be armored in place or at these higher elevations. The water quality certification limits dredging to 100 cubic yards.

### *Removal of abandoned In-River piers*

Existing pier structures within the waterway which will no longer serve a purpose will be removed to a depth of at least 24-inches below the natural streambed, the top of the footing, or to bedrock whichever is shallower. Waterways with artificially high sediment deposits which may erode after removal of the piers and/or footings should be removed to a lower elevation to avoid resuspension and dispersal in the future.

### *Recreational Navigation*

MassDOT and its contractors will ensure there is no unreasonable interference with navigation during and after construction and will provide the necessary public notice, including signage upstream and downstream, to ensure boating safety. If the waterway will be impassable for any time during construction, local public safety officials will be notified in advance of the start of work.

### *Construction Debris Containment*

All work shall be conducted in a manner that prevents any debris, lumber or construction materials and/or equipment from falling into the waterway. Any material or equipment that does fall into the waterway shall be removed. Parts of the former bridge that no longer serve a purpose will be removed. Except for the work authorized by this permit, nothing shall be in the waterway post-construction that was not there pre-construction. No later than 30 days after the completion of construction, a written certification by a registered professional engineer shall be obtained to verify and document that this has been completed. In addition, the permittee shall remove any pre-existing debris and solid waste from the waterway and embankment within the contract limits of the project.

### *Compliance Assurance*

Prior to the commencement of work authorized by this permit, MassDOT environmental personnel shall conduct a pre-construction meeting with the MassDOT contractor to ensure that the contractor has a copy of the permit and compliance verification form on site and is aware of the applicable standards and conditions.

Attachment 1  
DEP Water Quality Certificate Standard Form (WQC-SF)  
General Conditions

General Conditions:

1. There is no less damaging practicable alternative available and capable of being done after taking into consideration costs, existing technology, and logistics in light of overall project purposes.
2. The project authorized by this permit shall result in the loss of less than 5,000 square feet of vegetated wetlands or waters. Project dredging shall involve less than 100 cubic yards.
3. The project shall not result in the permanent impoundment of waters in a waterway or vegetated wetland
4. All vegetated wetlands which are impacted shall be replaced and/or restored at a 1:1 ratio.
5. No activity is authorized under this permit which affects greater than 1,000 sf of wetland resources within an Area of Critical Environmental Concern, an Outstanding Resource Water (ORW) or a barrier beach. No activity is authorized under this WQC-SF permit which results in salt marsh impacts. Projects with mapped habitat for rare species are eligible for a WQC-Standard Form, as long as the project has been reviewed and has received clearance from the MA DFW.
6. Temporary fill in waters and wetlands authorized by this permit (e.g. access roads) shall be properly stabilized, as per project plans, during use to prevent erosion. Temporary fill in wetlands shall be placed on geotextile fabric laid on existing wetlands grade. Temporary fills shall be disposed of at an upland site, suitably contained to prevent erosion and transport to a waterway or wetland. Temporary fill areas shall be restored to their original contours and seeded with native herbaceous vegetation.
7. Where work in wetlands and waterways is unavoidable particularly due to bridge abutment replacement and stabilization, turbidity shall be controlled as described on the attached plans. Temporary cofferdams constructed of steel sheeting, jersey barriers, sandbags or other suitable material shall be utilized to create a dry environment within the waterway for construction to occur. If cofferdams are proposed for use, documentation shall be provided which demonstrates the suitability of the proposed cofferdams design for the particular site conditions (e.g. stream bed, surficial geology, and hydrology) of the stream crossing. Sediment laden water will be pumped to an enclosure comprised of filter fabric, haybales or a combination of both which shall be used to filter the water prior to its return to the water course. Sedimentation enclosures shall be located in upland areas and shall be properly sized in order to provide adequate filtration of sediments so as not to impair the water quality of the receiving waters.
8. Construction equipment shall be kept out of wetlands and waterways except as described in this application

9. To prevent erosion and sedimentation from disturbed areas from entering the wetlands and waterways, the following erosion and sedimentation control measures will be taken:

Construction shall be scheduled so that areas shall be denuded or disturbed for only the duration necessary for the specific phase of construction. Siltation devices shall be used during all phases of construction to reduce flow velocity and intercept the sediment before it leaves the construction area. Siltation devices shall also be installed at the bottoms of disturbed embankments, at temporary slope drain outlets, as filter cores for check dams, around storm drain inlets and in front of the silt fences as applicable to the individual project site.

Siltation devices shall be installed before the commencement of any site work. These devices shall be inspected regularly and entrapped silt shall be removed and disposed of in an upland location greater than 100 ft. from wetland resource areas where feasible. Haybales and silt fences shall be maintained or replaced when clogged with sediment or deteriorated.

During all phases of construction, all disturbed or exposed areas shall be stabilized immediately after the grading operation is completed. In order to stabilize exposed areas, temporary or permanent vegetation or similar erosion control material shall be applied. Some combination of the following measures shall be utilized to provide sufficient sediment/erosion controls for all exposed areas:

fertilization to application amounts as recommended by the manufacturer;  
mulch or binder (including straw, bituminous, and/or jute mesh);  
topsoil, loam or plantable soil (4-inch minimum thickness);  
sod at critical locations (embankment grade break, ditch bottoms, and other susceptible areas); and  
other special vegetative applications as necessary

Temporary stabilization is practical when the final grading operation cannot be immediately completed and the area will be exposed for a considerable length of time (e.g. more than one month). Haybales and silt fence will be removed upon completion of project work, and entrapped silt shall be removed and disposed of in an upland location greater than 100 ft from wetland resource areas where feasible.

10. Waterway Crossings:

All temporary and permanent crossings of waterbodies shall be culverted, bridged, or otherwise designed to withstand and to prevent the restriction of high flows, and so as not to obstruct the movement of aquatic life indigenous to the waterbody.

Open trench excavation is not allowed in flowing waters. Check if project complies with this condition.

Bridge, culverts, or cofferdams shall be used for equipment access across streams (note: areas of fill and/or cofferdams must be included in total waterway/wetlands impacts to determine applicability of this general permit).

The period of work in waterways shall be determined by DMF/DFW in order to protect existing species and to ensure protection during annual spawning

periods. MHD has consulted with DMF/DFW in order to confirm species and spawning period and obtain recommendations as to the optimal timing for conducting the work.

11. DEP shall be permitted to make periodic inspections at any time deemed necessary in order to ensure that work is being performed in accordance with the terms and conditions of this permit. DEP may require construction engineering drawings for completed work which will be so indicated on the Water Quality Certificate
12. If DEP makes a determination regarding the eligibility of a project under this permit, and subsequently discovers that it has relied on false, incomplete or inaccurate information provided by the permittee, the permit shall not be valid.
13. If the permittee anticipates it will fail to complete the activity authorized under this permit within the permit term, the permittee shall request an extension from the Department. The request for an extension shall be made to DEP at least 30 days prior to the expiration of this Certification. If an extension is not granted, work will cease and the area shall be stabilized to prevent adverse impacts.
14. This permit does not apply to any existing or proposed activity in DEP jurisdiction associated with on-going DEP enforcement action (e.g. hazardous waste sites), until such time as the enforcement action is resolved or the DEP determines that the activity may proceed independently without compromising enforcement action.

---

The DEP may insert additional special conditions, as needed.

## Attachment 2

- Figure 1 Sandbag Cofferdam
  - Figure 2 Jersey Barrier Cofferdam
  - Figure 3 Steel Sheeting Cofferdam
  - Figure 4 Coated Fabric Steel Frame Cofferdam
  - Figure 5 Flume Pipe
  - Figure 6 Hay/Straw Bale Dewatering Basin  
Jersey Barrier Dewatering Basin
  - Figure 7 Filter Bag
  - Figure 8 Turbidity Curtain
-

**Figure 1**

## Sandbag Cofferdam

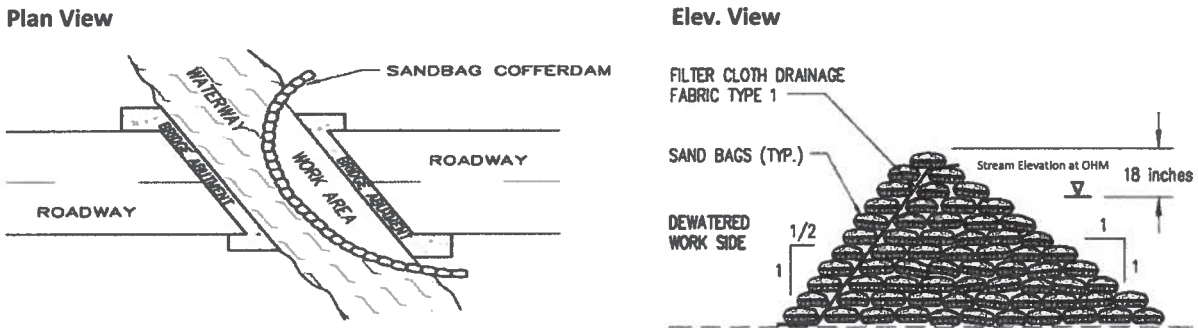

### Purpose

Sandbags can be manually stacked to form a temporary impervious cofferdam when encapsulated with an impervious poly-fabric liner. The sandbags can be filter bags filled with sand. This type of sandbag cofferdam can be used to impound or divert a waterway and is easily removed.

### Conditions Where Applicable

- Used when the waterway has a low flow rate.
- Used when the height of the sandbag cofferdam is less than 5 feet (stream height at ordinary high water is less than 3 feet - 6 inches).
- Used when heavy equipment is unavailable, unnecessary, or undesirable.

### Conditions Where NOT Applicable

- Concrete is not allowed in sand mixture.

### Construction

**Step 1-** Remove large rocks and branches from the area where the sand bags will be placed.

**Step 2 -** Lay out the poly-fabric liner with the center of the liner located over the center of the sandbag cofferdam.

**Step 3-** Place the sandbags to necessary height. The width of the cofferdam should be suitable to support the height of the cofferdam. Each row should be offset so the joints are staggered. The sandbags should be packed tightly together.

**Step 4-** Wrap the sandbag cofferdam in the poly-fabric liner and secure with a final layer of sandbags.

**Removal Methodology**

Sandbag cofferdam should be removed from the downstream end to the upstream end to prevent unnecessary sediment from entering the waterway.

**Maintenance**

Inspect the sandbags daily for water leaks and signs of instability and implement repair procedures accordingly.

**Typical Problems**

- Improperly placed sandbags cause leaks.
  - Height of sandbag cofferdam is insufficient.
-



**Figure 2**

**Jersey Barrier Cofferdam**

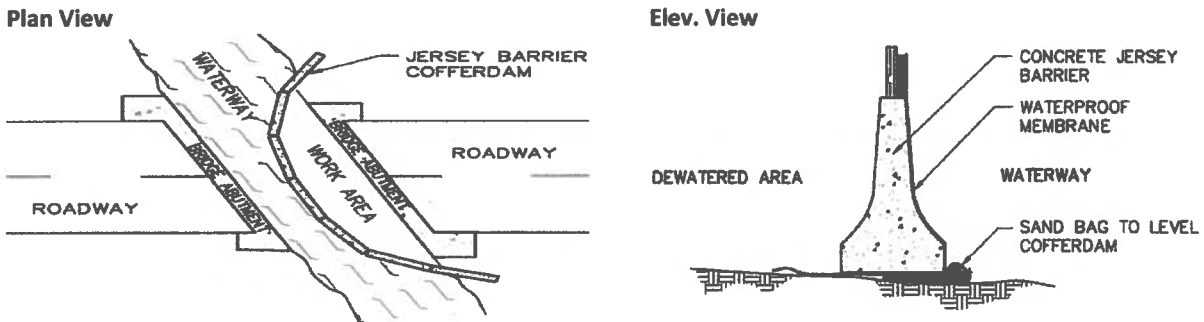

**Purpose**

A Jersey Barrier Cofferdam should be used for dewatering of shallow waterways with coarse substrates. Dewatering consists of placing barriers in only a portion of the waterway and allowing the main flow of the waterway to go around the cofferdam.

**Conditions Where Applicable**

The waterway being dewatered is less than 2 feet deep.

**Construction**

- Step 1-** The area that will act as the base of the cofferdam should be leveled with sand bags to prevent seepage.
- Step 2-** The barriers should be set up as closely packed as possible.
- Step 3-** A continuous or overlapping waterproof membrane should line the cofferdam on the in stream side and should continue under the cofferdam and extend beyond the dewatered side to prevent silt-laden water from seeping into the waterway.

**Removal Methodology**

Jersey barrier cofferdam should be removed from the downstream end to the upstream end to prevent unnecessary sediment from entering the waterway.

**Maintenance**

Inspect jersey barriers daily for water leaks and signs of instability and implement repair procedures accordingly.

**Typical Problems**

- Jersey barriers are not placed level or the height is insufficient
  - Improperly placed jersey barriers cause water leaks
-

**Figure 3**

### **Steel Sheet Pile Cofferdam**

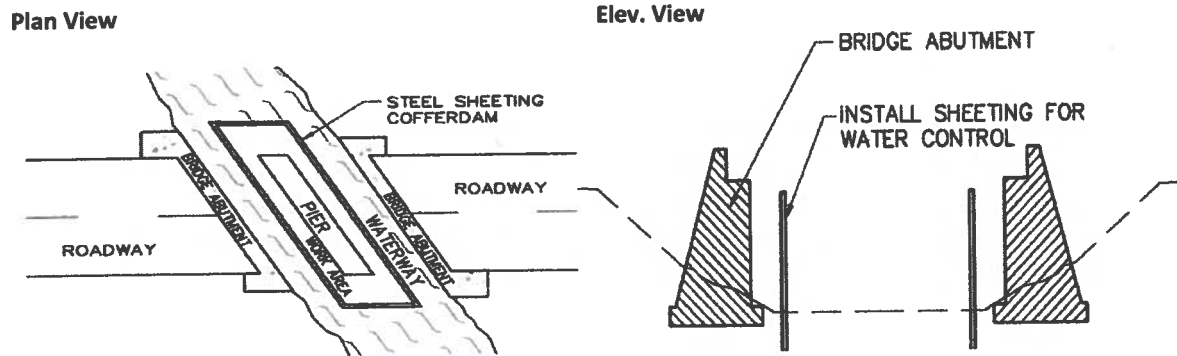

**Purpose**

Steel sheeting cofferdams can be used with bypass pumps to keep a work area moderately dry during construction. Steel sheets are driven into the ground and then interlocked to create a wall or barrier.

**Conditions Where Applicable**

- Where minimum channel disturbance is required.
- Where channel substrate is sufficiently free of stones or bedrock to allow the sheeting to be driven sufficiently deep into the channel.

**Conditions Where NOT Applicable**

- Small waterway with little or no flow.
- Where the access to drive steel sheets requires more disturbance to jurisdictional areas than other cofferdam types.
- Locations where rocks and other obstructions prevent steel sheets from being driven into the ground.

## Construction

**Step 1** - Be sure sheet is free of dirt, grease and other potential contaminants before installation.

**Step 2** - Install by placing and driving sheets with a backhoe, excavator, hammer or other suitable equipment.

**Step 3** - Ensure the sheets penetrate to a sufficient depth in order to bear the load of water being diverted.

**Step 4** - Overlap or interlock sheets in a manner that prevents any water from seeping into the work area as well as preventing sediment from the work area seeping into the waterway.

## Removal Methodology

Steel sheeting cofferdam should be removed from the downstream end to the upstream end to prevent unnecessary sediment from entering the waterway.

## Maintenance

Inspect steel sheets daily for water leaks and signs of instability and implement repair procedures accordingly.

## Typical Problems

- Improperly installed sheets cause leaks.
- Sheets not driven deep enough to withstand pressure of water.

**Figure 4**

**Coated Fabric Steel Frame Cofferdam**

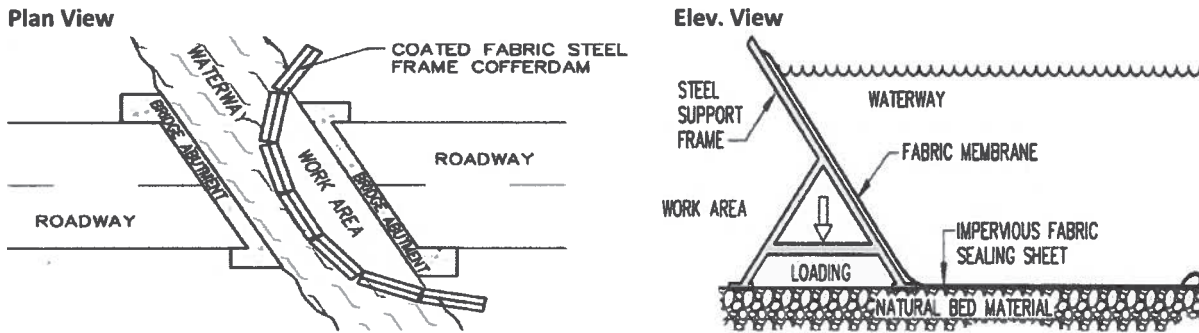

**Purpose**

A coated fabric steel frame cofferdam is used to form a temporary dry work area within a waterway. A coated fabric steel frame cofferdam can be used in streams with a higher flow rate conditions than a sandbag cofferdam.

**Conditions Where Applicable**

- The water is no more than 12 feet deep.
- For shallow water, the flow is up to 2 fps.
- For deep water, the flow is up to 1 fps.

**Construction**

This kind of cofferdam must be installed by a properly trained crew.

**Removal Methodology**

Coated fabric steel frame cofferdam should be removed from the downstream end to the upstream end to prevent unnecessary sediment from entering the waterway.

**Maintenance**

Inspect cofferdam daily for water leaks or erosion and implement repair procedures accordingly.

**Typical Problems**

There is a potential for water leaks if the sections of the cofferdam are not placed close enough together.

**Figure 5**

**Flume Pipe**

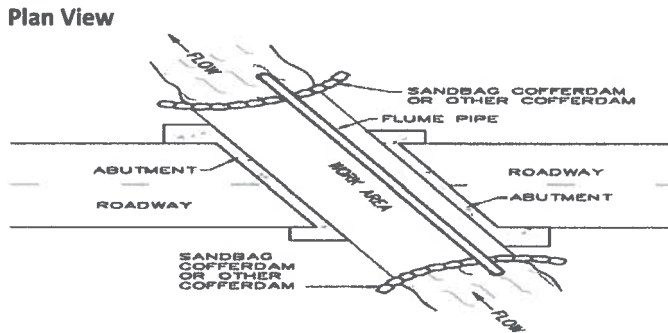

**Purpose**

A flume pipe is a temporary pipe installed to divert the flow of the waterway around the work area (but within the stream channel) without the use of pumping operations.

**Conditions Where Applicable**

- Where adequate slope and space exist between the upstream and downstream ends of the flume pipe.
- Headwall installations and some pipe/culvert replacements where adequate space is unavailable.

**Conditions Where NOT Applicable**

- When the pipe would adversely impact the aquatic habitat migration.

**Construction**

**Step 1-** Install sediment controls.

**Step 2-** Install flume pipe adjacent to work area. Provide a positive drainage slope from the upstream to the downstream side.

**Step 3-** Connect the downstream flume pipe into the downstream waterway. Place outlet of flume pipe to minimize erosion at the discharge site or provide temporary energy dissipation measures.

**Step 4-** Connect the upstream flume pipe into the upstream waterway.

**Step 5-** Construct a cofferdam at the upstream side of the waterway to divert the waterway into the flume pipe.

**Step 6-** Construct a cofferdam at the downstream side of the flume pipe to isolate work area.

**Step 7-** Upon completion of construction, remove the cofferdams.

### **Removal Methodology**

Remove the downstream cofferdam allowing the work area to become flooded. Then remove the flume pipe and then the upstream cofferdam.

### **Maintenance**

- Inspect cofferdams and flume pipes daily for damage or leakage.
- Remove accumulated sediment and debris from cofferdams and pipes.
- Inspect outlet for erosion.

### **Typical Problems**

- Improper amount of slope that impedes diverted flow.
  - Diverted flow bypasses the flume pipe and causes erosion as surface flow.
-

**Figure 6**

## Hay/Straw Bale Dewatering Basin

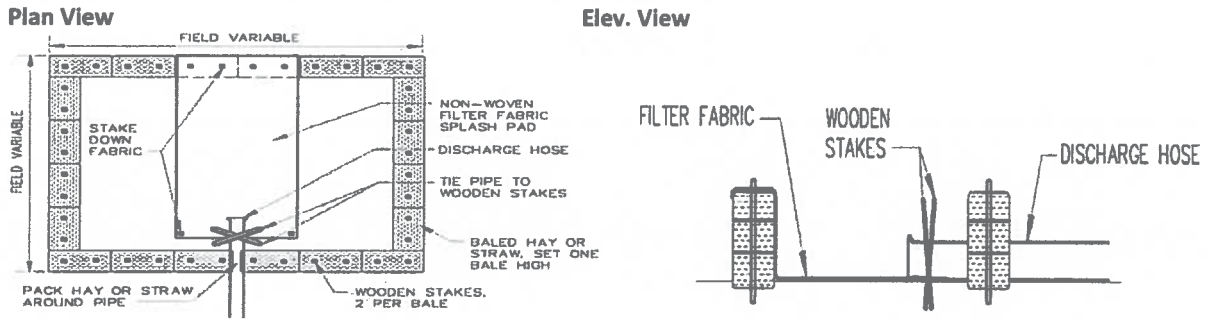

### Purpose

Hay/straw bale dewatering basins are used at sites where dewatering of the work area is required to perform work. The effluent is pumped into the dewatering basin to allow the heavier particles to settle out prior to being discharged.

### Conditions Where Applicable

- Where there is enough room in the work area to form the basin.
- Where water will be pumped from the work area.

### Conditions Where NOT Applicable

Not allowed to be constructed in jurisdictional wetlands.

### Construction

- Step 1-** The area that will act as the base of the basin should be leveled with sand bags to prevent seepage.
- Step 2-** The barriers should be set up as closely packed as possible.
- Step 3-** A continuous or overlapping non-woven geotextile fabric should line the base of the basin.



### **Removal Methodology**

Remove and dispose of sediment and haybales properly, outside of jurisdiction wetlands.

### **Maintenance**

- Inspect basin daily after each significant rainfall.
- Basin should be cleaned out when approximately one half full.
- Clean and replace hay/straw bales when needed.

### **Typical Problems**

- Inadequate basin capacities
  - Accumulated sediment not removed when needed.
  - Basins built in sandy soils may cause sloughing of slopes.
-

## Jersey Barrier Dewatering Basin

Plan View

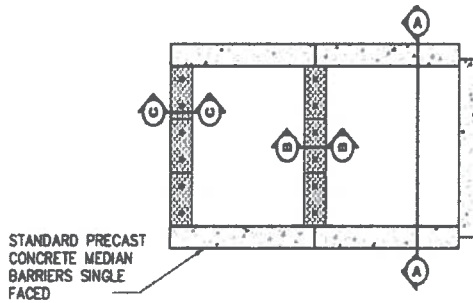

Elev. View

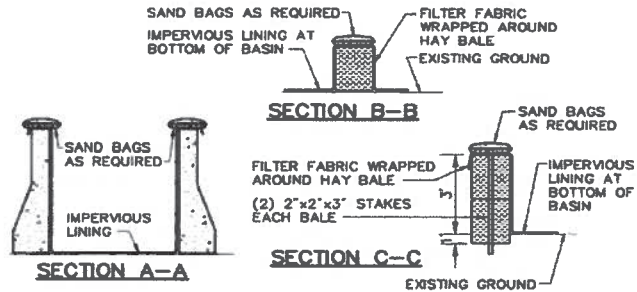

### Purpose

Jersey barrier dewatering basins are used at sites where dewatering of the work area is required to perform work. The effluent is pumped into the dewatering basin to allow the heavier particles to settle out prior to being discharged.

### Conditions Where Applicable

- Where there is enough room in the work area to form the basin.
- Where water will be pumped from the work area.

### Conditions Where NOT Applicable

- Not allowed to be constructed in jurisdictional wetlands.

### Construction

**Step 1-** The area that will act as the base of the basin should be leveled with sand bags to prevent seepage.

**Step 2-** The barriers should be set up as closely packed as possible.

**Step 3-** A non-woven geotextile fabric should be wrapped around the haybales. A waterproof membrane should line the base of the basin.

### **Removal Methodology**

Remove and dispose of sediment and haybales properly, outside of jurisdiction wetlands.

### **Maintenance**

- Inspect basin daily and after each significant rainfall.
- Basin should be cleaned out when approximately one half full.
- Replace hay/straw bales when needed.

### **Typical Problems**

- Inadequate basin capacities
  - Accumulated sediment not removed when needed.
  - Basins built in sandy soils may cause sloughing of slopes.
-

**Figure 7**

**Filter Bag**

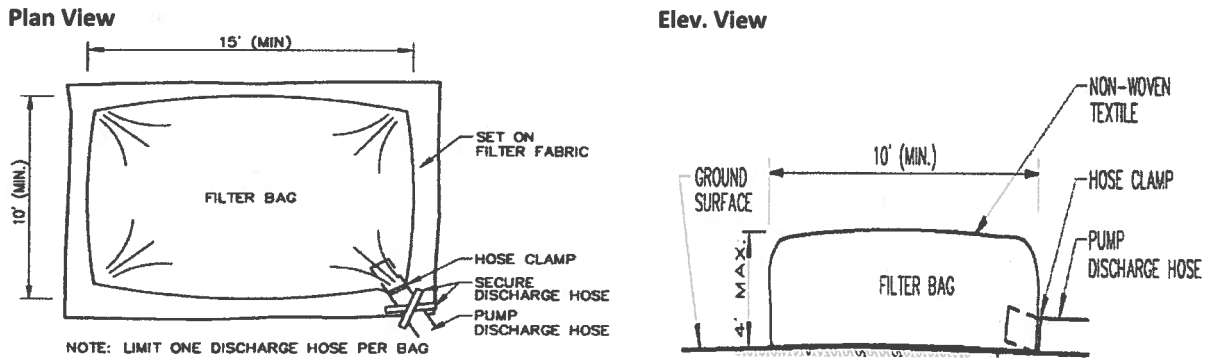

**Purpose**

Filter bags are used at sites where the construction site limitations do not allow for the construction of a dewatering basin. The effluent from the work area is pumped into a prefabricated silt bag. Water slowly filters out of the bag in a dispersed manner and the sediment is captured in the bag. Sediment control stone is used as a foundation for the bag.

**Conditions Where Applicable**

- When the effluent can be pumped out of the work area at a rate of 1500 gallons per minute or less.
- When the work area and dewatering volume is small.
- When there is not enough available upland area to construct a dewatering basin.
- When the construction activities will not require an extended period of time.

**Conditions Where NOT Applicable**

- Construction sites that will require large amounts of dewatering.

## **Construction**

- The silt bag should be at least 10' by 15'. The bag should be made from a nonwoven fabric and have sewn-in sleeve for receiving pump discharge.
- The bag seams should be sewn with a double needle machine using a high strength thread. The seams should have a wide width strength of at least 60 lb./in. (using test method ASTM D-4884).
- The silt bag should be placed on top of at least 6 inches of sediment control stone in an area that will drain away from the work area.

## **Removal Methodology**

Remove inlet hose and dispose of entire silt bag.

## **Maintenance**

- Inspect inlet pipe and bag for damage and blockage.
- Replace the bag when  $\frac{3}{4}$  full of sediment.

## **Typical Problems**

- Discharge too large for bag.
- Continued use when bag is full.
- Inlet pipe disconnected from bag.

**Figure 8**

## **Turbidity Curtain**

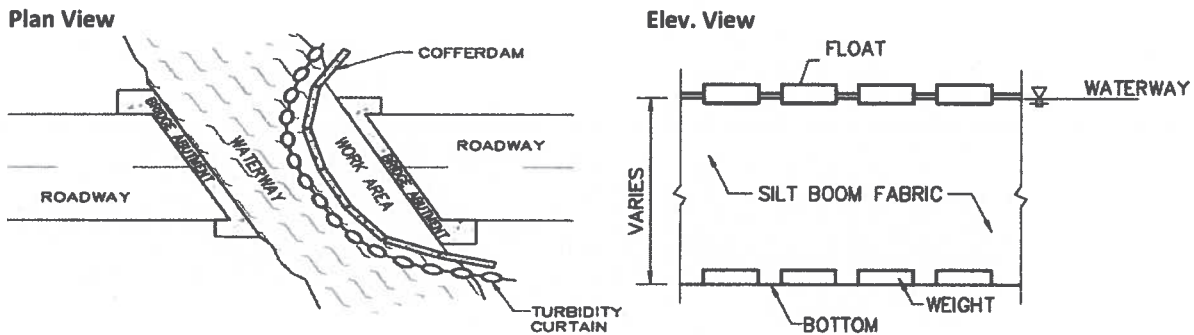

### **Purpose**

Turbidity curtains are used as an in-stream sediment control filtration device to isolate a cofferdam work area from the normal flow of the waterway.

### **Conditions Where Applicable**

- When performing work in a stream in a small localized area.
- Where stream height at ordinary high water is between 4 and 8 feet.
- When the repair or construction activities will not require an extended period of time to complete.

### **Conditions Where NOT Applicable**

- Across flowing streams. Turbidity curtains are not designed as prefabricated dams.
- Where water depth is below 4 feet.

### **Construction**

- The curtain should be made of tightly woven nylon, plastic or other non-deteriorating material.
- A flotation material with over 29 lbs./ft (43 kg/m) buoyancy should support the curtain material. A 5/16 inch (7.8 mm) galvanized chain should act as ballast for the floating curtain. Dual 5/16 inch (7.8mm ) galvanized wire ropes with a

heavy vinyl coating should be used as the load lines.

### **Removal Methodology**

Remove silt curtain from the upstream side first, being careful not to release sediment into the waterway while the silt curtain is removed.

### **Maintenance**

- Inspect the curtain, flotation and ballast to ensure the work area is securely partitioned from the stream flow.
- Remove accumulated debris.

### **Typical Problems**

- Does not permanently remove sediment.
  - Improper anchoring of curtain on channel bottom.
  - Tidal flows requiring frequent repositioning.
-

**MassDOT Stream Crossing Structures Rating Chart**

<b>Screening Level 1</b>		
<b>Does the culvert/bridge have any of the following conditions?</b>	<b>Yes</b>	<b>No</b>
Drop in inlet water elevation > 6 inches		
Outlet drop (perching) > 6 inches		
Flow contraction at inlet under base flows resulting in turbulence or in a water elevation drop > 6 inches		
Extensive tail water armoring (e.g., concrete or other synthetic apron, extensive riprap that is dissimilar to natural channel conditions)		
Other permanent physical barriers (e.g., fences, weirs, cross pipes, concrete aprons or channel extensions, weirs, check dams)		
<b>If the answer is "yes" to any of these conditions, the Crossing Rating = 0.</b>		

If none of these conditions is present, proceed to Screening Level 2.

<b>Screening Level 2</b>		
<b>Parameter</b>	<b>Scoring value</b>	<b>Score (enter applicable value)</b>
Limited tail water armoring: <ul style="list-style-type: none"> <li>• Armoring present, but not extensive</li> <li>• No armoring, or riprap similar in size and gradation to natural channel material</li> </ul>	5 10	
Temporary physical barriers <ul style="list-style-type: none"> <li>• Temporary barriers present e.g., beaver dams, debris dams, sediment accumulation</li> <li>• No barriers</li> </ul>	5 10	
Scour pool (wider than natural stream pools, banks eroded) <ul style="list-style-type: none"> <li>• Large (width or depth &gt; twice that of natural pools)</li> <li>• Small (width or depth ≤ twice that of natural pools)</li> <li>• None = 10</li> </ul>	0 5 10	
Embedment <ul style="list-style-type: none"> <li>• Not embedded</li> <li>• Partially embedded</li> <li>• Fully embedded &lt; 1'</li> <li>• Clear span, or Fully embedded ≥ 1'</li> </ul>	0 3 7 10	
Water depth <ul style="list-style-type: none"> <li>• Not comparable to natural channel</li> <li>• Comparable</li> </ul>	0 10	
Water Velocity <ul style="list-style-type: none"> <li>• Not comparable to natural channel</li> <li>• Comparable</li> </ul>	0 10	
<b>Total Score</b>	(10 min. 60 max.)	
If Total Score < 60, proceed to Screening Level 3A. If Total Score = 60, proceed to Screening Level 3B.		



Attachment 3

<b>Screening Level 3A (Level 2 score &lt; 60)</b>		
<b>Parameter</b>	<b>Scoring value</b>	<b>Score</b>
Score from Screening Level 2		
Substrate (bed material within culvert/bridge, compared to channel) <ul style="list-style-type: none"> <li>• Inappropriate (e.g., none, concrete rubble, completely different)</li> <li>• Contrasting (size/gradation significantly different)</li> <li>• Comparable</li> </ul>	0 5 10	
<b>Total cumulative score</b>		
If Total Cumulative Score is 10 to 34, <b>Crossing Rating = 1</b> If Total Cumulative Score is 35 to 67, <b>Crossing Rating = 2</b>		

<b>Screening Level 3B (Level 2 Score = 60)</b>			
<b>Parameter</b>			<b>Crossing Rating</b>
Substrate (bed material within culvert/bridge) <ul style="list-style-type: none"> <li>• Inappropriate (e.g., none, concrete rubble, completely different)</li> <li>• Contrasting (size/gradation significantly different)</li> <li>• If Comparable – go to next parameter</li> </ul>			2 3 ----
Span	Openness Ratio (feet)	Height (feet)	
• Constricts channel	---	---	<b>4</b>
• Equal to active channel	---	---	<b>5</b>
• Bankfull channel	<0.82	---	<b>5</b>
	0.82 to 1.63	---	<b>6</b>
	1.64 to 2.46	---	<b>7</b>
	>2.46	---	<b>8</b>
• ≥ 1.2 x bankfull channel	<0.82	---	<b>5</b>
	0.82 to 1.63	---	<b>7</b>
	1.64 to 2.46	< 6	<b>8</b>
		≥ 6	<b>9</b>
	>2.46	< 6	<b>8</b>
		≥ 6	<b>10</b>

**Rating as determined above is used in the Passage Classification Table, see next page.**

**Passage Classification for Existing Stream Crossing Structures**

<b>Crossing Rating</b>	<b>Passage Classification</b>	<b>Remarks</b>
0 to 1	Severe Barrier	The structure is considered a barrier to most aquatic and terrestrial wildlife.
2	Moderate Barrier	The structure may provide some passage for aquatic wildlife, and is likely a barrier to terrestrial wildlife. Further investigation is required to determine the extent to which it provides aquatic passage.
3 to 5	Minor Barrier	The structure is likely to provide aquatic wildlife passage, but has limited capacity for non-aquatic species.
6 to 8	Meets General Standards	The structure provides aquatic and terrestrial passage consistent with the General Standards of the Massachusetts River and Stream Crossing Standards. <sup>1</sup>
9 to 10	Meets Optimum Standards	The structure provides aquatic and terrestrial passage consistent with the Optimum Standards of the Massachusetts River and Stream Crossing Standards.

---

<sup>1</sup> Structures with a Rating Score of "8" may meet optimum standards where reduced openness (>1.64 feet (0.5 meter)) and height (>4 feet (1.2 meters)) requirements are applicable.



**US Army Corps  
of Engineers**<sup>®</sup>  
New England District

**Attachment 4  
Work Start Notification Form  
Massachusetts Department of Transportation  
Comprehensive Bridge Permit (NAE-2008-3745)**

Submit this **before** work commences to:

Chief, Permits & Enforcement Branch (MA)  
New England District  
U.S. Army Corps of Engineers  
696 Virginia Road  
Concord, MA 01742-2751

Call (978) 318-8335 with any questions.  
If faxed (978-318-8330) or emailed, you need to confirm receipt.

MassDOT Contact: \_\_\_\_\_

Phone/email: \_\_\_\_\_

Work Location (approx. address): \_\_\_\_\_  
City, State & Zip Code: \_\_\_\_\_

Latitude/Longitude coordinates: \_\_\_\_\_

Waterway name: \_\_\_\_\_

Area of wetland impact: \_\_\_\_\_ square feet (SF)

Area of waterway impact: \_\_\_\_\_ SF

Area of compensatory mitigation provided: \_\_\_\_\_ SF

Will American Recovery and Reinvestment Act (ARRA) funds be used for any of this project?  yes  no

Contractor: \_\_\_\_\_

Contractor Address: \_\_\_\_\_

City, State & Zip Code: \_\_\_\_\_

Phone(s)/Email: \_\_\_\_\_

Scheduled Work Dates: Start: \_\_\_\_\_ Finish: \_\_\_\_\_

**NOTIFICATION OF ADMINISTRATIVE APPEAL OPTIONS AND PROCESS AND  
REQUEST FOR APPEAL**

<b>Applicant:</b>		<b>File Number: NAE-</b>	<b>Date:</b>
<b>Attached is:</b>		<b>See Section below</b>	
<b>X</b>	<b>INITIAL PROFFERED PERMIT (Standard Permit or Letter of permission)</b>	<b>A</b>	
	<b>PROFFERED PERMIT (Standard Permit or Letter of permission)</b>	<b>B</b>	
	<b>PERMIT DENIAL</b>	<b>C</b>	
	<b>APPROVED JURISDICTIONAL DETERMINATION</b>	<b>D</b>	
	<b>PRELIMINARY JURISDICTIONAL DETERMINATION</b>	<b>E</b>	

**SECTION I - The following identifies your rights and options regarding an administrative appeal of the above decision. Additional information may be found at <http://usace.army.mil/inet/functions/cw/cecwo/reg> or Corps regulations at 33 CFR Part 331.**

**A: INITIAL PROFFERED PERMIT: You may accept or object to the permit.**

- **ACCEPT:** If you received a Standard Permit, you may sign the permit document and return it to the District Engineer for final authorization in care of "Regulatory Division." If you received a Letter of Permission (LOP), you may accept the LOP and your work is authorized. Your signature on the Standard Permit or acceptance of the LOP means that you accept the permit in its entirety, and waive all rights to appeal the permit, including its terms and conditions, and approved jurisdictional determinations associated with the permit.
- **OBJECT:** If you object to the permit (Standard or LOP) because of certain terms and conditions therein, you may request that the permit be modified accordingly. You must complete Section II of this form and return the form to the District Engineer, in care of the Chief, Regulatory Division, as specified in the last paragraph of the coverletter. Your objections must be received within 60 days of the date of this notice, or you will forfeit your right to appeal the permit in the future. Upon receipt of your letter, the District Engineer will evaluate your objections and may: (a) modify the permit to address all of your concerns, (b) modify the permit to address some of your objections, or (c) not modify the permit having determined that the permit should be issued as previously written. After evaluating your objections, the District Engineer will send you a proffered permit for your reconsideration, as indicated in Section B below.

**B: PROFFERED PERMIT: You may accept or appeal the permit**

- **ACCEPT:** If you received a Standard Permit, you may sign the permit document and return it to the District Engineer for final authorization in care of "Regulatory Division." If you received a Letter of Permission (LOP), you may accept the LOP and your work is authorized. Your signature on the Standard Permit or acceptance of the LOP means that you accept the permit in its entirety, and waive all rights to appeal the permit, including its terms and conditions, and approved jurisdictional determinations associated with the permit.
- **APPEAL:** If you choose to decline the proffered permit (Standard or LOP) because of certain terms and conditions therein, you may appeal the declined permit under the Corps of Engineers Administrative Appeal Process by completing Section II of this form and sending the form to the Division Engineer in care of: Michael G. Vissichelli, Administrative Appeals Review Officer, North Atlantic Division, Corps of Engineers, North Atlantic Fort Hamilton Military Community, Bldg. 301, General Lee Avenue, Brooklyn, NY 11252-6700. Contact info: (718) 765-7163 or [michael.g.vissichelli@usace.army.mil](mailto:michael.g.vissichelli@usace.army.mil). The Division Engineer must receive this form within 60 days of the date of this notice.

• **C: PERMIT DENIAL:** You may appeal the denial of a permit under the Corps of Engineers Administrative Appeal Process by completing Section II of this form and sending the form to the Division Engineer in care of: Michael G. Vissichelli, Administrative Appeals Review Officer, North Atlantic Division, Corps of Engineers, Fort Hamilton Military Community, Bldg. 301, General Lee Avenue, Brooklyn, NY 11252-6700. Contact info: (718) 765-7163 or [michael.g.vissichelli@usace.army.mil](mailto:michael.g.vissichelli@usace.army.mil). The Division Engineer must receive this form within 60 days of the date of this notice.

**D: APPROVED JURISDICTIONAL DETERMINATION:** You may accept or appeal the approved JD or provide new information.

- **ACCEPT:** You do not need to notify the Corps to accept an approved JD. Failure to notify the Corps within 60 days of the date of this notice means that you accept the approved JD in its entirety, and waive all rights to appeal the approved JD.
- **APPEAL:** If you disagree with the approved JD, you may appeal the approved JD under the Corps of Engineers Administrative Appeal Process by completing Section II of this form and sending the form to the Division Engineer in care of: Michael G. Vissichelli, Administrative Appeals Review Officer, North Atlantic Division, Corps of Engineers, Fort Hamilton Military Community, Bldg. 301, General Lee Avenue, Brooklyn, NY 11252-6700. Contact info: (718) 765-7163 or [michael.g.vissichelli@usace.army.mil](mailto:michael.g.vissichelli@usace.army.mil). The Division Engineer must receive this form within 60 days of the date of this notice.

**E: PRELIMINARY JURISDICTIONAL DETERMINATION:** You do not need to respond to the Corps regarding the preliminary JD. The Preliminary JD is not appealable. If you wish, you may request an approved JD (which may be appealed), by contacting the Corps district at the address below for further instruction. Also you may provide new information for further consideration by the Corps to reevaluate the JD.

**SECTION II - REQUEST FOR APPEAL or OBJECTIONS TO AN INITIAL PROFFERED PERMIT**

**REASONS FOR APPEAL OR OBJECTIONS:** (Describe your reasons for appealing the decision or your objections to an initial proffered permit in clear concise statements. You may attach additional information to this form to clarify where your reasons or objections are addressed in the administrative record.)

**ADDITIONAL INFORMATION:** The appeal is limited to a review of the administrative record, the Corps memorandum for the record of the appeal conference or meeting, and any supplemental information that the review officer has determined is needed to clarify the administrative record. Neither the appellant nor the Corps may add new information or analyses to the record. However, you may provide additional information to clarify the location of information that is already in the administrative record.

**POINT OF CONTACT FOR QUESTIONS OR INFORMATION:**

If you have questions regarding this decision and/or the appeal process you may contact Ms. Ruth Ladd at:

Chief, Policy Analysis/Technical Support Branch  
Corps of Engineers  
696 Virginia Road  
Concord, MA 01742 or by calling (978) 318-8818

**RIGHT OF ENTRY:** Your signature below grants the right of entry to Corps of Engineers personnel, and any government consultants, to conduct investigations of the project site during the course of the appeal process. You will be provided a 15-day notice of any site investigation, and will have the opportunity to participate in all site investigations.

_____ Signature of appellant or agent.	Date:	Telephone number:
---	-------	-------------------

## Applicant Options with Initial/Proffered Permit

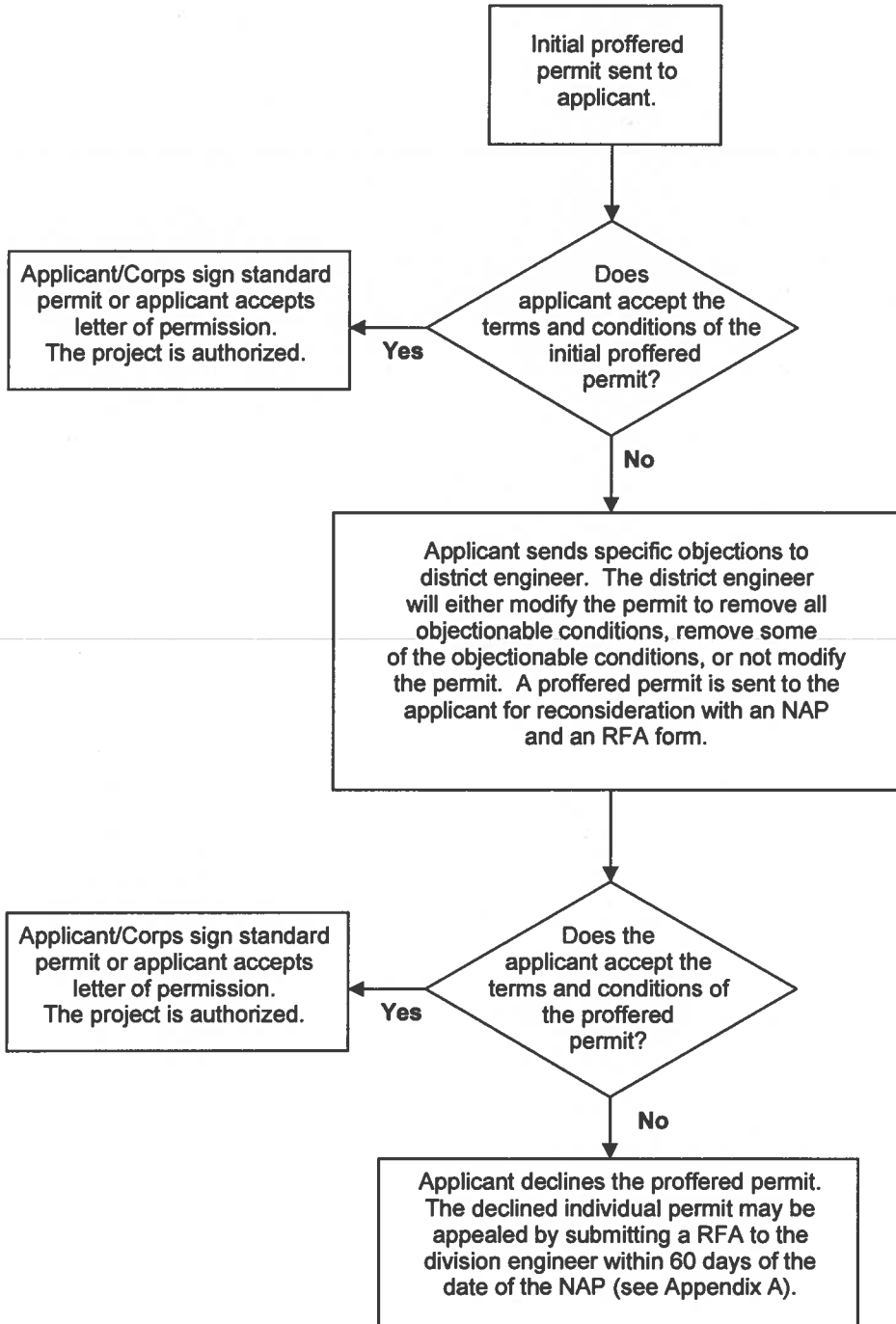

**Appendix B**

## Administrative Appeal Process for Approved Jurisdictional Determination

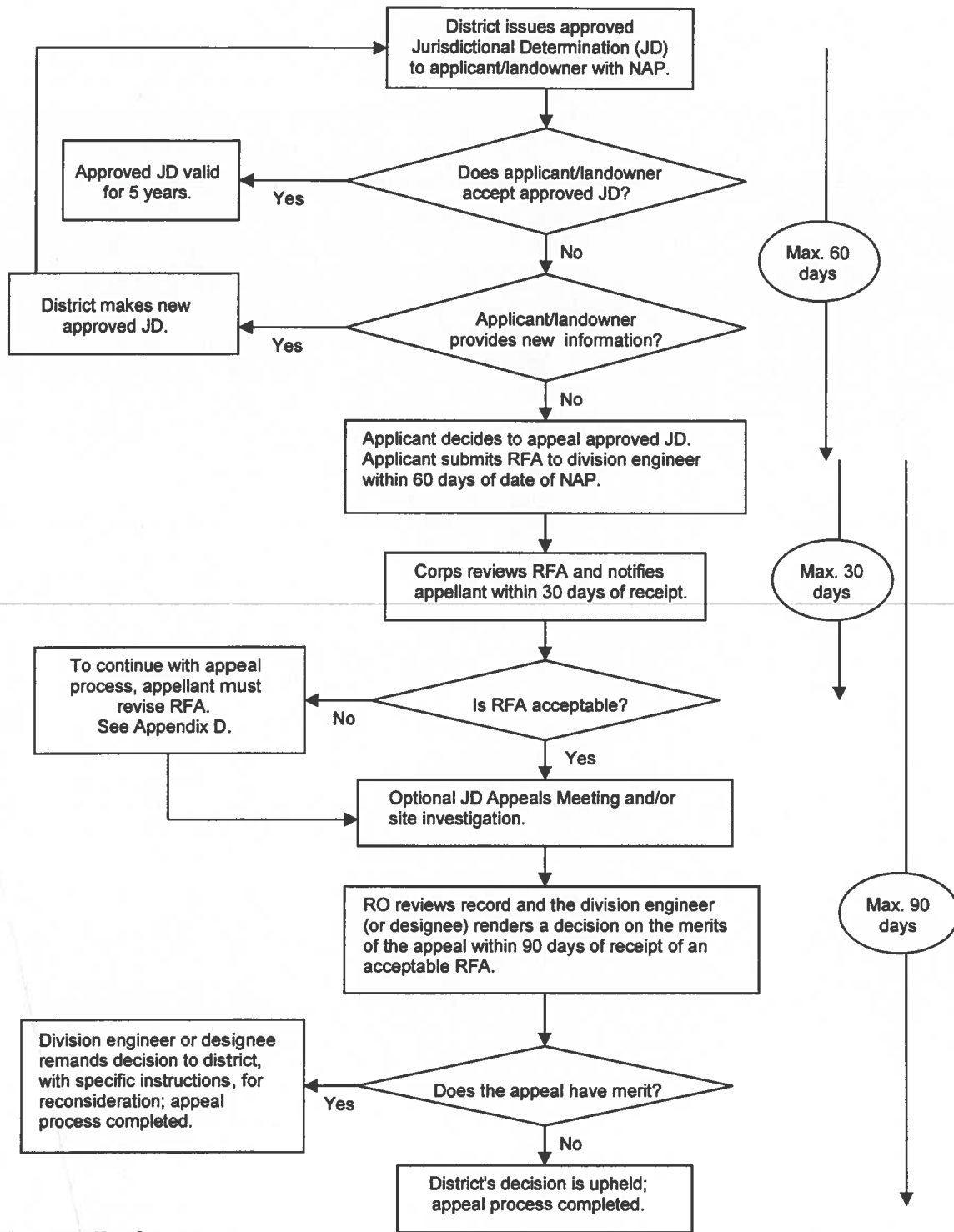

[Intentionally Left Blank]



## **Appendix E**

### **Massachusetts 401 Water Quality Regulations**



314 CMR: DIVISION OF WATER POLLUTION CONTROL

314 CMR 9.00: 401 WATER QUALITY CERTIFICATION FOR DISCHARGE OF DREDGED OR FILL MATERIAL, DREDGING, AND DREDGED MATERIAL DISPOSAL IN WATERS OF THE UNITED STATES WITHIN THE COMMONWEALTH

Section

- 9.01: Authority, Jurisdiction, and Purpose
- 9.02: Definitions
- 9.03: Activities Not Requiring an Application
- 9.04: Activities Requiring an Application
- 9.05: Submission of an Application
- 9.06: Criteria for Evaluation of Applications for Discharge of Dredged or Fill Material
- 9.07: Criteria for Evaluation of Applications for Dredging and Dredged Material Management
- 9.08: Variance
- 9.09: 401 Water Quality Certification
- 9.10: Appeals
- 9.11: Enforcement
- 9.12: Authorization of Emergency Action
- 9.13: Effective Date, Transition Rule, and Severability

9.01: Authority, Jurisdiction, and Purpose

(1) Authority. 314 CMR 9.00 is adopted pursuant to § 27 of the Massachusetts Clean Waters Act, M.G.L. c. 21, §§ 26 through 53 and establishes procedures and criteria for the administration of Section 401 of the federal Clean Water Act, 33 U.S.C. 1251 *et seq.*, for the discharge of dredged or fill material, dredging, and dredged material disposal in waters of the United States within the Commonwealth. 314 CMR 9.07 is also adopted pursuant to M.G.L. c. 21A § 14; M.G.L. c. 21C; M.G.L. c. 21E; M.G.L. 21H; M.G.L. c. 91, §§ 52 through 56; and M.G.L. c. 111, §§ 150A through 150A½ relative to upland reuse and disposal of dredged materials.

(2) Jurisdiction. 314 CMR 9.00 applies to the discharge of dredged or fill material, dredging, and dredged material disposal activities in waters of the United States within the Commonwealth which require federal licenses or permits and which are subject to state water quality certification under 33 U.S.C. 1251, *et seq.*. The federal agency issuing a permit initially determines the scope of geographic and activity jurisdiction. (*e.g.* the Corps of Engineers for Section 404 permits for the discharge of dredged or fill material). 314 CMR 9.07 also applies to any dredging project and the management of dredged material within the marine boundaries and at upland locations within the Commonwealth.

(3) Purpose. 314 CMR 9.00 is promulgated by the Department to carry out its statutory obligations to certify that proposed discharges of dredged or fill material, dredging, and dredged material disposal in waters of the United States within the Commonwealth will comply with the Surface Water Quality Standards and other appropriate requirements of state law. 314 CMR 9.00 implements and supplements the Surface Water Quality Standards at 314 CMR 4.00 and is a requirement of state law under 33 U.S.C. 1251, *et seq.* 314 CMR 9.00 implements and supplements 314 CMR 4.00 by, without limitation:

- (a) protecting the public health and restoring and maintaining the chemical, physical, and biological integrity of the water resources of the Commonwealth by establishing requirements, standards, and procedures for the following:
  - 1. monitoring and control of activities involving discharges of dredged or fill material, dredging, and dredged material disposal or placement;
  - 2. the evaluation of alternatives for dredging, discharges of dredged or fill material, and dredged material disposal or placement; and
  - 3. public involvement regarding dredging, discharges of dredged or fill material, and dredged material placement, reuse or disposal.
- (b) establishing a certification program for the Department to persons seeking to discharge dredged or fill material, conduct dredging, and place, reuse or dispose of dredged material.

9.02: Definitions

Activity. Any proposed project, scheme or plan of action which will result in a discharge of dredged or fill material subject to jurisdiction under 33 U.S.C. 1251, *et seq.* or dredging and dredged material management. In determining thresholds for and conducting evaluations of applications, the entirety of the activity, including likely future expansions, shall be considered and not separate phases or segments thereof. The activity includes temporary and permanent, direct and indirect, and cumulative impacts from the construction and ongoing operation of a project. The calculation of square footage shall include the total of the applicable areas proposed to be lost from the impacts of the activity, without reduction for replication or restoration.

Aggrieved Person. Any person who, because of a 401 Water Quality Certification determination by the Department, may suffer an injury in fact which is different either in kind or magnitude from that suffered by the general public and which is within the scope of interests identified in 314 CMR 9.00.

Applicant. A person proposing any activity that will result in a discharge of dredged or fill material, or a discharge from dredging or dredged material disposal in any water of the United States within the Commonwealth.

Aquatic Ecosystem. Waters of the United States within the Commonwealth, including wetlands, that serve as habitat for interrelated and interacting communities and populations of plants and animals.

Area of Critical Environmental Concern. An area designated by the Secretary pursuant to M.G.L. c. 21A, § 2 (7) and 301 CMR 12.00.

Bordering Vegetated Wetlands. Any land or surface area so defined by the Massachusetts Wetlands Protection Act, M.G.L. c. 131, § 40 and 310 CMR 10.55(2).

Clean Water Act. The federal statute at 33 U.S.C. 1251 *et seq.* which contains §§ 401 and 404.

Cold-water Fisheries. Waters in which the mean of the maximum daily temperature over a seven day period generally does not exceed 68°F (20°C) and, when other ecological factors are favorable (such as habitat), are capable of supporting a year round population of cold-water stenothermal aquatic life. Waters designated as cold-water fisheries by the Department in 314 CMR 4.00 and water designated as cold-water fishery resources by the Division of Fisheries and Wildlife are cold-water fisheries. Waters where there is evidence based on a fish survey that a cold-water fishery and habitat exist are also cold-water fisheries. Cold-water fish include but are not limited to brook trout (*Salvelinus fontinalis*), rainbow trout (*Oncorhynchus mykiss*), brown trout (*Salmo trutta*), creek chubsucker (*Erimyzon oblongus*), and fallfish (*Semotilus corporalis*).

Confined Aquatic Disposal (CAD). A subaqueous facility (typically a constructed cell or natural depression) into which dredged sediment is placed and then isolated from the surrounding environment.

Confined Disposal Facility (CDF). A facility created in open water or wetlands consisting of confinement walls or berms built up against or extending into existing land.

Corps of Engineers. The United States Army Corps of Engineers, New England Division.

Critical Area. Outstanding Resources Waters as designated in 314 CMR 4.00, Special Resource Waters as designated in 314 CMR 4.00, recharge areas for public water supplies as defined in 310 CMR 22.02 (Zone Is, Zone IIs and Interim Wellhead Protection Areas for ground water sources and Zone As for surface water sources), bathing beaches as defined in 105 CMR 445.000, cold-water fisheries, and shellfish growing areas.

Department. The Massachusetts Department of Environmental Protection.

9.02: continued

Discharge of Dredged or Fill Material. Any addition of dredged or fill material into, including any redeposit of dredged material within, waters of the United States within the Commonwealth. The term includes, but is not limited to:

- (a) direct placement of fill, including any material used for the primary purpose of replacing with dry land or of changing the bottom elevation of a wetland or water body,
- (b) runoff from a contained land or water disposal area, and
- (c) the placement of pilings when it has the effect of fill material.

Disposal Site. A structure, well, pit, pond, lagoon, impoundment, ditch, landfill or other place or area, excluding ambient air or surface water, where uncontrolled oil or hazardous material has come to be located as a result of any spilling, leaking, pouring, ponding, emitting, emptying, discharging, injecting, escaping, leaching, dumping, discarding, or otherwise disposing of such oil or hazardous material and is a “disposal site” as defined in M.G.L.c. 21E.

Dredged Material. Sediment and associated materials that are moved from below the mean high tide line for coastal waters and below the high water mark for inland waters during dredging activities.

Dredged Material Disposal. The transport, placement, or deposition of sediments or other material after dredging.

Dredging - The removal or repositioning of sediment or other material from below the mean high tide line for coastal waters and below the high water mark for inland waters. Dredging shall not include activities in bordering or isolated vegetated wetlands.

Environmental Impact Report. The report described in the Massachusetts Environmental Policy Act, M.G.L. c. 30, §§ 61 through 62H and regulations at 301 CMR 11.00.

Environmental Monitor. The publication described in 301 CMR 11.19(1).

Environmentally Sensitive Site Design. Design that incorporates low impact development techniques to prevent the generation of stormwater and non-point source pollution by reducing impervious surfaces, disconnecting stormwater sheet flow paths, and treating stormwater at its source, maximizing open space, minimizing disturbance, protecting natural features and processes, and/or enhancing wildlife habitat.

Fastland. Land above mean high water formed by the placement of dredged or fill material into waters of the United States within the Commonwealth.

Final Order of Conditions. The Order of Conditions issued by the Commissioner of the Department after an adjudicatory hearing or, if no request for a hearing has been filed, the Superseding Order or, if no request for a Superseding Order has been filed, the Order of Conditions issued under the Wetlands Protection Act and 310 CMR 10.05.

Ground Water. Water below the land surface in a saturated zone including perched ground water.

High Water Mark. The present arithmetic mean of high water heights observed over a one-year period using the best available data as determined by the Department.

Illicit Discharge. Discharge that is not entirely comprised of stormwater. Notwithstanding the foregoing, an illicit discharge does not include discharges from the following activities or facilities: firefighting, water line flushing, landscape irrigation, uncontaminated ground water, potable water sources, foundation drains, air conditioning condensation, footing drains, individual resident car washing, flows from riparian habitats and wetlands, dechlorinated water from swimming pools, water used for street washing and water used to clean residential buildings without detergents.

9.02: continued

Improvement Dredging. Any dredging in an area which has not been previously dredged or which extends the original dredged width, depth, length or otherwise alters the original boundaries of a previously dredged area.

Intermediate Facility. A site or location that is to be utilized, on either a project-specific temporary or permanent basis, to manage dredged material prior to its ultimate reuse or disposal (e.g., barge unloading, stockpiling or storage, dewatering, processing or treatment, truck or train loading or unloading).

Isolated Vegetated Wetlands. Vegetated areas subject to jurisdiction under 33 U.S.C. 1251, *et seq.* that are not bordering vegetated wetlands subject to jurisdiction under M.G.L. c. 131, § 40 and 310 CMR 10.55(2).

Land Uses with Higher Potential Pollutant Loads. Land uses identified in 310 CMR 22.20B(2), 310 CMR 22.20C(2)(a) through (k) and (m), 310 CMR 22.21(2)(a)(1) through (8), and 310 CMR 22.21(2)(b)(1) through (6); areas within a site that are the location of activities that are subject to an individual National Pollutant Discharge Elimination System (NPDES) Permit or the NPDES Multi-Sector General Permit; auto fueling facilities (gas stations); exterior fleet storage areas; exterior vehicle service and equipment cleaning areas; marinas and boatyards; parking lots with high intensity use; confined disposal facilities, and disposal sites.

Lot. An area of land in one ownership, with definite boundaries.

Low Impact Development Techniques. Innovative stormwater management systems that are modeled after natural hydrologic features. Low impact development techniques manage rainfall at the source using uniformly distributed decentralized micro-scale controls. Low impact development techniques use small cost-effective landscape features located at the lot level.

Maintenance Dredging. Dredging in accordance with a valid license or permit in any previously authorized dredged area, which does not extend the originally dredged depth, width or length.

Massachusetts Environmental Policy Act or MEPA. M.G.L. c. 30, §§ 61 through 62H and regulations at 301 CMR 11.00.

Massachusetts Oil and Hazardous Materials Release Prevention and Response Act or Chapter 21E. M.G.L. c. 21E, §§ 1 through 18 and implementing regulations at 310 CMR 40.0000, the Massachusetts Contingency Plan (MCP).

Mean High Tide Line. – The line where the arithmetic mean of the high water heights observed over a specific 19-year metonic cycle (the National Tidal Datum Epoch) meets the shore and shall be determined using hydrographic survey data of the National Ocean Survey of the U.S. Department of Commerce.

Mixing Zone. A mixing zone is the limited volume of water allowing for the initial dilution of a discharge, e.g., from dredging or disposal in waters.

National Environmental Policy Act or NEPA. 42 U.S.C. §§ 4321 through 4345.

Non-invasive Sampling Activities. Sampling activities, which include the collection of water, soil or sediment samples by techniques (e.g., hand-held augers) that will not significantly disturb existing wetland resources areas as defined in the Massachusetts Wetland Protection Act and the Federal Clean Water Act.

Notice of Intent. The document described in 310 CMR 10.05(4).

Oil and Hazardous Material (OHM). The definitions included in 310 CMR 40.0000.

Outstanding Resource Water. A surface water of the Commonwealth so designated in the Massachusetts Surface Water Quality Standards at 314 CMR 4.00.

9.02: continued

Person. Any agency or political subdivision of the Commonwealth or the federal government, public or private corporation or authority, individual, partnership or association, or other entity, including any officer of a public or private agency or organization.

Qualified Environmental Professional (QEP). An individual who is knowledgeable about the procedures and methods for characterizing dredged material and contaminated media; is familiar with Massachusetts and federal regulations applicable to the management of such materials; performs or oversees the management of sediment and/or contaminated soil as an integral part of his or her professional duties; and is professionally licensed or certified in a discipline related to environmental assessment (*i.e.*, engineering, geology, or soil science) by the state or a recognized professional organization.

Rare and Endangered Species Habitat. Areas identified as habitat for rare or endangered species by the Massachusetts Division of Fisheries and Wildlife's Natural Heritage Program as published in the Massachusetts Natural Heritage Atlas at the time an application is submitted.

Real Estate Subdivision. The division of a tract of land into two or more lots, including division where approval is required and where approval is not required under the Subdivision Control Law, M.G.L. c.41, §§ 81K through 81GG.

Redevelopment. For purposes of the Stormwater Management Standards as provided in 314 CMR 9.06(6)(a) through (e), redevelopment is defined to include the following projects:

- (a) maintenance and improvement of existing roadways including widening less than a single lane, adding shoulders, correcting substandard intersections, improving existing drainage systems and repaving;
- (b) development, rehabilitation, expansion and phased projects on previously developed sites provided the redevelopment results in no net increase in impervious area; and
- (c) remedial projects specifically designed to provide improved stormwater management such as projects to separate storm drains and sanitary sewers and stormwater retrofit projects.

Salt Marsh. A coastal wetland as defined in M.G.L. c. 131, § 40 and 310 CMR 10.32(2).

SARA 312 Generator. A facility that is required by the Emergency Planning and Community right to Know Act (EPCRA) also known as Title III of the Superfund Amendments and Reauthorization Act of 1989 (SARA Title III) to submit an inventory of the location of hazardous chemicals which are located at the site.

Sediment. All inorganic or organic matter, including detritus, situated under tidal waters below the mean high water line as defined in 310 CMR 10.23; and for inland waters below the upper boundary of a bank, as defined in 310 CMR 10.54(2), which abuts and confines a water body.

Secretary. The Secretary of the Executive Office of Environmental Affairs.

Shellfish Growing Area. Land under the ocean, tidal flats, rocky intertidal shores and marshes and land under salt ponds when any such land contains shellfish. Shellfish growing areas include land that has been identified and shown on a map published by the Division of Marine Fisheries as a shellfish growing area including any area identified on such map as an area where shellfish harvesting is prohibited. Shellfish growing areas shall also include land designated by the Department in 314 CMR 4.00 as suitable for shellfish harvesting with or without depuration. In addition, shellfish growing areas shall include shellfish growing areas designated by the local shellfish constable as suitable for shellfishing based on the density of shellfish, the size of the area, and the historical and current importance of the area for recreational and commercial shellfishing.

Single and Complete Project. The total project proposed or accomplished by one or more persons, including any multiphased activity.

9.02: continued

Special Aquatic Sites means those site identified in Subpart E of 40 CFR Part 230, 404(b)(1), including sanctuaries and refuges, wetlands, mud flats, vegetated shallows, coral reefs, and riffle and pool complexes. They are geographical areas, large or small, possessing special ecological characteristics of productivity, habitat, wildlife protection, or other important and easily disrupted ecological values. These areas are generally recognized as significantly influencing or positively contributing to the general overall environmental health or vitality of the entire ecosystem of a region.

Stormwater Best Management Practice. Structural or nonstructural technique for managing stormwater to prevent or reduce non-point source pollutants from entering surface waters or ground waters. A structural stormwater best management practice includes a basin, discharge outlet, swale, rain garden, filter, or other stormwater treatment practice or measure either alone or in combination including without limitation any overflow pipe, conduit or weir control structure that:

- (a) is not naturally occurring;
- (b) is not designed as a wetland replication area; and
- (c) has been designed, constructed and installed for the purpose of collecting, storing, discharging, recharging or treating stormwater.

Nonstructural stormwater best management practices include source control and pollution prevention measures.

Stormwater Management System. System for conveying, collecting, storing, discharging, recharging or treating stormwater on-site including stormwater best management practices and any pipes and outlets intended to transport and discharge stormwater to the ground water, a surface water or a municipal separate storm sewer system.

Surface Waters. All waters other than groundwaters within the jurisdiction of the Commonwealth, including, without limitation, rivers, streams, lakes, ponds, springs, impoundments, estuaries, wetlands, coastal waters, and vernal pools.

Vernal Pool. A waterbody that has been certified by the Massachusetts Division of Fisheries and Wildlife as a vernal pool. In the event of a conflict of opinion or the lack of a clear boundary delineation certified by the Division of Fisheries and Wildlife or the Department, the applicant may submit an opinion certified by a registered professional engineer, supported by engineering calculations, as to the boundary of the vernal pool. The maximum extent of the waterbody shall be based upon the total volume of runoff from the drainage area contributing to the vernal pool and shall be further based upon a design storm of 2.6 inches of precipitation in 24 hours.

Waters of the Commonwealth. All waters within the Commonwealth, including without limitation, rivers, streams, lakes, ponds, springs, impoundments, estuaries, wetlands, coastal waters and ground waters.



9.02: continued

Waters of the United States within the Commonwealth. Navigable or interstate waters and their tributaries, adjacent wetlands, and other waters or wetlands within the borders of the Commonwealth where the use, degradation, or destruction could affect interstate or foreign commerce as determined by the Corps of Engineers. Bordering and isolated vegetated wetlands and land under water are waters of the United States within the Commonwealth when they meet the federal jurisdictional requirements defined at 33 CFR 328 through 329.

Water-dependent. Uses and facilities which require direct access to, or location in, marine, tidal or inland waters and which therefore cannot be located away from those waters, including any uses and facilities defined as water-dependent in 310 CMR 9.00.

401 Water Quality Certification or Certification. The document issued by the Department to the applicant and the appropriate federal agency under 33 U.S.C. 1251, *et seq.*, M.G.L. c. 21, § 27 and 314 CMR 9.00 certifying, conditioning, or denying an activity.

Wetlands Protection Act. M.G.L. c. 131, § 40 and regulations at 310 CMR 10.00.

9.03: Activities Not Requiring an Application

The activities identified in 314 CMR 9.03(1) through (6) do not require an individual 401 Water Quality Certification application provided the specified conditions are met. The Department has certified these activities through its certification of the Corps of Engineers' Programmatic General Permit (PGP) for Massachusetts effective January 20, 2005.

(1) Less than 5000 sq. ft. with an Order of Conditions. Activities conducted in compliance with the Wetlands Protection Act and receiving a Final Order of Conditions which meets all applicable performance standards under 310 CMR 10.00, provided that:

- (a) the Final Order of Conditions permits work that results in the loss of up to 5,000 square feet cumulatively of bordering and isolated vegetated wetlands and land under water. Both bordering and isolated vegetated wetlands must be delineated on the plans contained in the Notice of Intent and described on a form prescribed by the Department; and
- (b) the Final Order of Conditions includes conditions requiring at least 1:1 replacement of bordering vegetated wetlands under 310 CMR 10.55(4)(b);
- (c) if applicable, the activity conforms to the Waterways Crossing requirements at General Condition 21 in the Programmatic General Permit (PGP); and
- (d) the proposed work is not subject to 314 CMR 9.04.

(2) Beach Nourishment. Beach nourishment activities with a Final Order of Conditions issued under M.G.L. c. 131, § 40.

(3) Dredging Less than 100 c.y. Dredging and dredged material disposal of less than 100 cubic yards, provided that a Final Order of Conditions has been issued and the proposed work is not subject to 314 CMR 9.04 and the work qualifies for Category One of the Programmatic General Permit (PGP). Dredged sediment generated from such activities shall be managed in accordance with the provisions of 314 CMR 9.07(9), (10), and (11) and may be used for beach nourishment activities or reuse within the shoreline under a Final Order of Conditions issued under M.G.L. c. 131, § 40.

(4) Agriculture or Aquaculture Exempt under the Wetlands Protection Act. Normal maintenance and improvement of land in agricultural or aquacultural use that is exempt from the Wetlands Protection Act, as defined and performed in accordance with 310 CMR 10.04 (Agriculture) including the alternatives analysis, as applicable, performed by the Natural Resources Conservation Service (formerly Soil Conservation Service) or 310 CMR 10.04 (Aquaculture). The provisions of 314 CMR 9.04 do not apply.

## 9.03: continued

(5) Less than 5000 sq. ft. of Isolated Vegetated Wetlands. Any activity in an area not subject to jurisdiction of the Wetlands Protection Act which is subject to 33 U.S.C. 1251, *et seq.* (i.e., isolated vegetated wetlands) which will result in the loss of up to 5000 square feet cumulatively of bordering and isolated vegetated wetlands and land under water, provided there is no discharge of dredged or fill material to any habitat for rare and endangered species or to any Outstanding Resource Water.

(6) Planning and Design Activities. Activities that are temporary in nature, have negligible impacts, and are necessary for planning and design purposes such as the installation of monitoring wells, exploratory borings, sediment sampling, and surveying. The applicant shall notify the Department and conservation commission at least ten days prior to commencing the activity. Notification is not required if a valid, unexpired Final Negative Determination of Applicability has been issued for the work as described 310 CMR 10.05(3)(b). Notification shall include a description of the activity, the location of the proposed activity and measures to be taken to avoid or minimize impacts. The site shall be substantially restored to its condition prior to the activity.

The Department will notify the persons to whom an Order of Conditions is issued not later than ten business days of its receipt by the Department that based on the information available to the Department the criteria of 314 CMR 9.03 have not been met. If the impacts to resource areas, as defined in the Massachusetts Wetland Protection Act and the Federal Clean Water Act, or the project size increases from the description filed with the Notice of Intent, or there are any inaccuracies therein, the applicant must notify the Department in writing and request a determination that the criteria of 314 CMR 9.03 have been met before the activity begins.

9.04: Activities Requiring an Application

The activities identified in 314 CMR 9.04(1) through (11) require a 401 Water Quality Certification application and are subject to the Criteria for Evaluation of Applications for the Discharge of Dredged or Fill Material in 314 CMR 9.06 and/or 314 CMR 9.07:

(1) More than 5000 sq. ft. Any activity in an area subject to 310 CMR 10.00 which is also subject to 33 U.S.C. 1251, *et seq.* and will result in the loss of more than 5000 square feet cumulatively of bordering and isolated vegetated wetlands and land under water.

(2) Outstanding Resource Waters. Dredging in, or any activity resulting in any discharge of dredged or fill material to any Outstanding Resource Water.

(3) Real Estate Subdivision - Any discharge of dredged or fill material associated with the creation of a real estate subdivision, unless there is a valid, unexpired Final Order of Conditions, followed by a Certificate of Compliance, and a recorded deed restriction providing notice to subsequent purchasers limiting the amount of fill for the single and complete project to less than 5000 square feet cumulatively of bordering and/or isolated vegetated wetlands and land under water and the discharge is not to an Outstanding Resource Water. Real estate subdivisions include divisions where approval is required and where approval is not required under the Subdivision Control Law, M.G.L. c. 41, §§ 81K through 81GG. Discharges of dredged or fill material to create the real estate subdivision include but are not limited to discharges resulting from the construction of roads, drainage, sidewalks, sewer systems, buildings, septic systems, wells, and accessory structures.

(4) Activities Exempt under M.G.L. c. 131, § 40. Any activity not subject to M.G.L. c. 131, § 40 and which is subject to 33 U.S.C. 1251, *et seq.* and will result in any discharge of dredged or fill material to bordering vegetated wetlands or land under water.

(5) Routine Maintenance. Routine maintenance of existing channels, such as mosquito control projects or road drainage maintenance, that will result in the annual loss of more than 5000 square feet cumulatively of bordering and isolated vegetated wetland and land under water will be evaluated under the criteria of 314 CMR 9.06. A single application may be submitted and a single certification may be issued for repeated routine maintenance activities on an annual or multi-year basis not to exceed five years.

9.04: continued

- (6) More than 5000 sq. ft. of Isolated Vegetated Wetlands. Any activity in an area not subject to jurisdiction of M.G.L. c. 131, § 40 but which is subject to 33 U.S.C. 1251, *et seq.* (*i.e.*, isolated vegetated wetlands) and which will result in the loss of more than 5000 square feet cumulatively of bordering and isolated vegetated wetlands and land under water.
- (7) Rare and Endangered Species Habitat in Isolated Vegetated Wetlands. Any activity resulting in the discharge of dredged or fill material to an isolated vegetated wetland that has been identified as habitat for rare and endangered species.
- (8) Salt Marsh. Any activity resulting in the discharge of dredged or fill material in any salt marsh.
- (9) Individual 404 Permit. Any activity subject to an individual Section 404 permit by the Corps of Engineers.
- (10) Agricultural Limited Project. Agricultural work, not exempt under M.G.L. c. 131, § 40, referenced in and performed in accordance with 310 CMR 10.53(5). Provided the activity does not result in any discharge of dredged or fill material to an Outstanding Resource Water, such work will be presumed to meet the criteria of 314 CMR 9.06 where a comparable alternatives analysis is performed or approved by the Natural Resources Conservation Service (formerly Soil Conservation Service) and included in the Notice of Intent.
- (11) Discretionary Authority. Any activity where the Department invokes discretionary authority to require an application based on cumulative effects of multiphased activities, cumulative effects of dredging, or from the discharge of dredged or fill material to bordering or isolated vegetated wetlands or land under water, or other impacts which may jeopardize water quality. The Department will issue a written notice of and statement of reasons for its determination to invoke this discretionary authority not later than ten business days after its receipt of an Order of Conditions.
- (12) Dredging Greater than 100 cubic yards. Any dredging or dredged material disposal of more than 100 cubic yards not meeting the requirements of 314 CMR 9.03(3).
- (13) Any activity not listed in 314 CMR 9.03 or 314 CMR 9.04 is an activity requiring an application subject to the requirements of 314 CMR 9.05 and 9.06 through 9.13 as applicable.

9.05: Submission of an Application

(1) Application Requirements. An applicant for 401 Water Quality Certification shall submit an application on the forms in the 401 Water Quality Certification application package currently available from the Department. The application shall be prepared in accordance with instructions contained in the Department's application and submitted to the appropriate address(es). Failure to complete an application where required, to provide additional information by the requested deadline when an application is deficient, to provide public notice in the form specified, to notify other agencies where required, or to submit information for a single and complete project shall be grounds for denial of certification. The applicant has the burden of demonstrating that the criteria of 314 CMR 9.06, 9.07, or 9.08 have been met.

For projects permitted under 314 CMR 9.07, the applicant may request in writing a pre-application meeting with the Department. The Department has the discretion to grant such a request.

## 9.05: continued

Demonstration or Pilot Projects. Any person who wishes to establish a demonstration or pilot sediment management project, related to activities within the jurisdiction of the 401 Certification, for the purpose of demonstrating the effectiveness and utility of an alternative or innovative management technology shall submit an application to the Department for a demonstration project permit/certification, notify the applicable board(s) of health and conservation commission(s) of the municipality(ies) where the project is proposed and consult with appropriate wildlife and/or fisheries agencies. The Department shall not approve a demonstration or pilot project unless it determines that the project will not cause or contribute to significant pollution of the air, water, or other natural resources of the Commonwealth; the project has merit and seeks to improve operational aspects of dredged materials management, produce significant cost savings, or serves to increase protection of human health and the environment; and, the applicant has provided adequate proof of financial assurance. The Department may approve a demonstration or pilot project for a limited time, with renewal contingent upon satisfactorily achieving project objectives and adequately protecting public health, safety, and the environment.

(2) Fee and Review Schedule. The fee and regulatory review schedule for actions by the Department in the review of a 401 Water Quality Certification application are set forth in the Timely Action Schedule and Fee Provisions at 310 CMR 4.00.

(3) Public Notice of an Application: A public notice of an application for 401 Water Quality Certification shall be published by the applicant within ten days of submitting an application at the applicant's expense in a newspaper of general circulation within the area of the proposed activity, including, as applicable, the area where the following activities will occur: the discharge of dredged or fill material, the dredging activity, the location of any intermediate facilities, the site of any upland or in-water sediment placement. The public notice shall contain:

- (a) the name and address of the applicant and property owner;
- (b) the location of the proposed activity;
- (c) a brief description of the activity;
- (d) the name and address of the person from whom additional information may be obtained;
- (e) the 21 day time period within which the public may comment;
- (f) the office and address within the Department to which comments should be addressed;
- and
- (g) a statement that any ten persons of the Commonwealth, any aggrieved person, or any governmental body or private organization with a mandate to protect the environment that has submitted written comments may also appeal the Department's Certification and that failure to submit comments before the end of the public comment period may result in the waiver of any right to an adjudicatory hearing.

A person submitting an application for 401 Water Quality Certification who is also subject to M.G.L. c. 131, § 40, 310 CMR 10.00 and/or M.G.L. c. 91 and 310 CMR 9.00 may provide joint public notice by appending to the notice provided under 310 CMR 10.05(5) or 310 CMR 9.13 a statement that an application for 401 Water Quality Certification is pending before the Department, provided that the joint notice contains the information in 314 CMR 9.05(3)(a) through (g). A person submitting an application for a dredging project shall concurrently file a copy of this public notice with the Board(s) of Health in the community(ies) in which each of the dredging or dredged material management activities, sites and/or facilities is to be located. A person submitting an application for the discharge of dredged or fill material to, or dredging within, an Outstanding Resource Water shall also publish a notice in the *Environmental Monitor*, and the 21 day time period within which the public may comment shall extend from the later of the date of publication of the newspaper or *Environmental Monitor* notice. All written comments providing relevant information shall be considered.

(4) The Department will conduct a site visit, providing notice to the applicant, the conservation commission of the city or town where the activity will occur, and any persons or groups which have submitted written comments prior to the date the site visit is scheduled. If the Department has previously inspected the site prior to issuing a Superseding Order of Conditions, receives no public comments in writing, or otherwise determines a site visit is not necessary or useful to its evaluation, it shall set forth its reasons in writing.

9.06: Criteria for the Evaluation of Applications for Discharge of Dredged or Fill Material

(1) No discharge of dredged or fill material shall be permitted if there is a practicable alternative to the proposed discharge that would have less adverse impact on the aquatic ecosystem, so long as the alternative does not have other significant adverse environmental consequences.

(a) An alternative is practicable if it is available and capable of being done after taking into consideration costs, existing technology, and logistics in light of overall project purposes.

(b) Where the activity associated with the discharge does not require access or proximity to or siting within wetlands and waters to fulfill its basic purpose (*i.e.*, is not "water dependent"), practicable alternatives that do not involve the discharge of dredged or fill material are presumed to be available, unless clearly demonstrated otherwise. In addition, all practicable alternatives to the proposed activity, which do not involve a discharge, are presumed to have less adverse impact on the aquatic ecosystem unless clearly demonstrated otherwise.

(c) The scope of alternatives to be considered shall be commensurate with the scale and purpose of the proposed activity, the impacts of the proposed activity, and the classification, designation and existing uses of the affected wetlands and waters in the Surface Water Quality Standards at 314 CMR 4.00.

1. For activities associated with access for one dwelling unit, the area under consideration for practicable alternatives will be limited to the lot. For activities associated with the creation of a real estate subdivision, the area under consideration will be limited to the subdivided lots and any adjacent lots the applicant formerly owned, presently owns, or can reasonably obtain an ownership interest.

2. For any activity resulting in the loss of more than one acre cumulatively of bordering and isolated vegetated wetlands and land under water, alternative sites not presently owned by the applicant which could reasonably be obtained, utilized, expanded or managed will be considered by the Department, but only if such information is required in an Environmental Impact Report or in an alternatives analysis conducted by the Corps of Engineers for an individuals 404 permit.

(2) No discharge of dredged or fill material shall be permitted unless appropriate and practicable steps have been taken which will avoid and minimize potential adverse impacts to the bordering or isolated vegetated wetlands, land under water or ocean, or the intertidal zone. For discharges to bordering or isolated vegetated wetlands, such steps shall include a minimum of 1:1 restoration or replication. The Department may waive the requirement for 1:1 restoration or replication for projects which will restore or otherwise improve the natural capacity of any wetland or other water of the Commonwealth pursuant to 314 CMR 9.06(8). However, no such project may be permitted which will have any adverse effect on specified habitat sites of rare vertebrate or invertebrate species as specified in 310 CMR 10.00.

(3) No discharge of dredged or fill material shall be permitted to Outstanding Resource Waters, except for the activities specified in 314 CMR 9.06(3)(a) through (k), which remain subject to an alternatives analysis and other requirements of 314 CMR 9.06 and/or 314 CMR 9.07:

(a) Projects conducted or approved by public or private water suppliers in the performance of their responsibilities and duties to protect the quality of the water in the watersheds, or to maintain, operate and improve the waterworks system, provided that such projects are implemented in accordance with applicable federal and state laws, regulations, and requirements;

(b) Activities determined by the Department to be for the express purpose and intent of maintaining or enhancing the resource for its designated use, after consultation with the entity, if any, with direct control of the water resource or governing water use;

(c) Maintenance, repair, replacement or reconstruction but not substantial enlargement of existing and lawfully located structures or facilities including buildings, roads, railways, utilities and coastal engineering structures;

(d) Where the designation was for public water supply purposes, activities subject to the comprehensive public water supply protection program enacted by the legislature for the Ware, Quabbin, and Wachusett watersheds in the Watershed Protection Act, St. 1992 c. 36 and M.G.L. c. 92. Any activity for which an applicant has been granted a variance by the Department of Conservation and Recreation pursuant to 350 CMR 11.06(3) or for a discharge of dredged or fill material into a tributary that the Department of Conservation and Recreation has exempted pursuant to 350 CMR 11.06(4). A span or other bridging technique shall be considered an alternative in accordance with 314 CMR 9.06(3)(e) and the

## 9.06: continued

Department will consult with the Department of Conservation and Recreation in reviewing the alternatives.

(e) Access for the construction of dwelling units and associated utilities:

1. For the loss of more than 5,000 square feet cumulatively of bordering and isolated vegetated wetland and land under water for access to any number of dwelling units, a span or other bridging technique is presumed to be practicable. New permanent crossings shall conform with the General Standards contained in the latest version of the Massachusetts River and Stream Crossing Standards: Technical Guidelines.
2. For the loss of less than 5,000 square feet cumulatively of bordering and isolated vegetated wetland and land under water for access to any number of dwelling units, an embedded culvert, span or other bridging technique is presumed to be practicable. New permanent crossings shall conform with the General Standards contained in the most recent version of the Massachusetts River and Stream Crossing Standards: Technical Guidelines.

These presumptions may be overcome upon a showing of credible evidence that based on site considerations, impact on the resource, or cost considerations, a span or other bridging technique is or is not practicable.

(f) Construction of utilities, public or private roadways or other access except as specified in 314 CMR 9.06(3)(e), railroad track and rail beds and facilities directly related to their operation. These activities require use of a span or other bridging technique, unless the Department determines, based on information contained in a Department 401 alternatives analysis, a Corps of Engineers Section 404 alternatives analysis, or an Environmental Impact Report and the Secretary's certificate, that this alternative is not practicable, would not have less adverse impact on the aquatic ecosystem, or would have other significant adverse environmental consequences.

(g) Operations to clean up, prevent, assess, monitor, contain, or mitigate releases of hazardous materials or wastes, including landfill closures and activities undertaken in accordance with M.G.L. c. 21E and 310 CMR 40.0000.

(h) Projects which have received a variance under 314 CMR 9.08 or under 310 CMR 10.36 or 310 CMR 10.58 where consideration has been given to the Outstanding Resource Water designation in the variance analysis.

(i) Access to land in agricultural or aquacultural use, of a nature suitable to the use as defined in 310 CMR 10.04: Agriculture; Aquaculture.

(j) Operations to clean up, prevent, assess, monitor, contain, or mitigate releases of oil or hazardous materials or wastes, including landfill closures under M.G.L. c. 111, §150A-150A½ and 310 CMR 16.00 and 19.000 and activities undertaken in accordance with M.G.L. c. 21E and 310 CMR 40.0000.

(k) Maintenance, repair, replacement, or reconstruction of structures or facilities for water-dependent uses. In addition, the enlargement of structures or facilities for water-dependent uses is allowed only in following limited circumstances:

1. in an Outstanding Resource Water that is designated for purposes other than a public water supply; or
2. in an Outstanding Resource Water that is located within an Area of Critical Environmental Concern if the Department determines that the enlargement of structures or facilities for water-dependent uses is consistent with a resource management plan for the ACEC that has been adopted by the municipality and approved by the Secretary, provided, however, that any fill or structure associated with the enlargement activity is located entirely within an area of previously filled tidelands.

(4) Discharge of dredged or fill material to an Outstanding Resource Water specifically identified in 314 CMR 4.06(1)(d) (e.g., vernal pools, within 400 feet of a water supply reservoir and any other areas so designated) is prohibited as provided therein unless a variance is obtained under 314 CMR 9.08.

(5) No discharge of dredged or fill material is permitted for the impoundment or detention of stormwater for purposes of controlling sedimentation or other pollutant attenuation. Discharge of dredged or fill material may be permitted to manage stormwater for flood control purposes only where there is no practicable alternative and provided that best management practices are implemented to prevent sedimentation or other pollution. No discharge of dredged or fill material is permitted for the impoundment or detention of stormwater in Outstanding Resource Waters for any purpose.

## 9.06: continued

- (6)(a) Except as otherwise provided in 314 CMR 9.06, stormwater discharges shall be provided with best management practices to attenuate pollutants and to provide a setback from the receiving water or wetlands in accordance with the following Stormwater Management Standards as further defined and specified in the Massachusetts Stormwater Handbook:
1. No new stormwater conveyances (*e.g.* outfalls) may discharge untreated stormwater directly to or cause erosion in wetlands or waters of the Commonwealth.
  2. Stormwater management systems shall be designed so that post-development peak discharge rates do not exceed pre-development peak discharge rates. This Standard may be waived for land subject to coastal storm flowage as defined in 310 CMR 10.04.
  3. Loss of annual recharge to ground water shall be eliminated or minimized through the use of infiltration measures including environmentally sensitive site design, low impact development techniques, stormwater best management practices, and good operation and maintenance. At a minimum, the annual recharge from the post-development site shall approximate the annual recharge from pre-development conditions based on soil type. This Standard is met when the stormwater management system is designed to infiltrate the required recharge volume as determined in accordance with the Massachusetts Stormwater Handbook.
  4. Stormwater management systems shall be designed to remove 80% of the average annual post-construction load of Total Suspended Solids (TSS). This Standard is met when:
    - a. Suitable practices for source control and pollution prevention are identified in a long-term pollution prevention plan and thereafter are implemented and maintained;
    - b. Structural stormwater best management practices are sized to capture the required water quality volume determined in accordance with the Massachusetts Stormwater Handbook; and
    - c. Pretreatment is provided in accordance with the Massachusetts Stormwater Handbook.
  5. For land uses with higher potential pollutant loads, source control and pollution prevention shall be implemented in accordance with the Massachusetts Stormwater Handbook to eliminate or reduce the discharge of stormwater runoff from such land uses to the maximum extent practicable. If through source control and/or pollution prevention all land uses with higher potential pollutant loads cannot be completely protected from exposure to rain, snow, snow melt and stormwater runoff, the proponent shall use the specific structural stormwater BMPs determined by the Department to be suitable for such use as provided in the Massachusetts Stormwater Handbook. Stormwater discharges from land uses with higher potential pollutant loads shall also comply with the requirements of the Massachusetts Clean Waters Act, M.G.L. c. 21, §§ 26 through 53, and the regulations promulgated thereunder at 314 CMR 3.00, 314 CMR 4.00 and 314 CMR 5.00.
  6. Stormwater discharges within the Zone II or Interim Wellhead Protection Area of a public water supply and stormwater discharges near or to any other critical area require the use of the specific source control and pollution prevention measures and the specific structural stormwater best management practices determined by the Department to be suitable for managing discharges to such area as provided in the Massachusetts Stormwater Handbook. A discharge is near a critical area, if there is a strong likelihood of a significant impact occurring to said area, taking into account site-specific factors. Stormwater discharges to Outstanding Resource Waters and Special Resource Waters shall be removed and set back from the receiving water or wetland and receive the highest and best practical method of treatment. A "storm water discharge" as defined in 314 CMR 3.04(2)(a)1. or (b) to an Outstanding Resource Water or Special Resource Water shall comply with 314 CMR 3.00 and 314 CMR 4.00. Stormwater discharges to a Zone I or Zone A are prohibited, unless essential to the operation of the public water supply.
  7. A redevelopment project is required to meet the following Stormwater Management Standards only to the maximum extent practicable: Standard 2, Standard 3, and the pretreatment and structural stormwater best management practice requirements of Standards 4, 5, and 6. Existing stormwater discharges shall comply with Standard 1 only to the maximum extent practicable. A redevelopment project shall also comply with all other requirements of the Stormwater Management Standards and improve existing conditions.

9.06: continued

8. A plan to control construction related impacts including erosion, sedimentation and other pollutant sources during construction and land disturbance activities (construction period erosion, sedimentation and pollution prevention plan) shall be developed and implemented.

9. A long-term operation and maintenance plan shall be developed and implemented to ensure that the stormwater management system functions as designed.

10. All illicit discharges to the stormwater management system are prohibited.

(b) The Stormwater Management Standards set forth in 314 CMR 9.06(6)(a)1. through 10. shall not apply to:

1. A single -family house;
2. Housing development and redevelopment projects comprised of detached single-family dwellings with four or fewer lots provided that there are no stormwater discharges that may affect a critical area;
3. Multi- family housing development and redevelopment projects, with four or fewer units, including condominiums, cooperatives, apartment buildings, and townhouses, provided that there are no stormwater discharges that may potentially affect a critical area; and
4. Emergency repairs to roads or drainage systems.

(c) The Stormwater Management Standards shall apply to the maximum extent practicable to the following:

1. Housing development and redevelopment projects comprised of detached single-family dwellings with four or fewer lots that have a stormwater discharge that may potentially affect a critical area;
2. Multi-family housing development and redevelopment projects with four or fewer units, including condominiums, cooperatives, apartment buildings and townhouses, that have a stormwater discharge may potentially affect a critical area;
3. Housing development and redevelopment projects comprised of detached single-family dwellings, with five to nine lots, provided there is no stormwater discharge that may potentially affect a critical area; and
4. Multi-family housing development and redevelopment projects of five to nine units, including condominiums, cooperatives, apartment buildings, and townhouses, provided there is no stormwater discharge that may potentially affect a critical area.
5. Marinas and boatyards provided that the hull maintenance, painting, and service areas are protected from exposure to rain, snow, snow melt, and stormwater runoff; and
6. Footpaths, bikepaths and other paths for pedestrian and/or nonmotorized access.

(d) For phased projects the determination of whether the Stormwater Management Standards apply is made on the single and complete project including all phases. When proposing a development or redevelopment project subject to the Stormwater Management Standards, proponents shall consider environmentally sensitive site design that incorporates low impact development techniques in addition to stormwater best management practices.

(e) Project proponents seeking to demonstrate compliance with some or all of the Stormwater Management Standards to the maximum extent practicable shall demonstrate that:

1. They have made all reasonable efforts to meet each of the standards;
2. They have made a complete evaluation of possible stormwater management measures including environmentally sensitive site design and low impact development techniques that minimize land disturbance and impervious surfaces, structural stormwater best management practices, pollution prevention, erosion and sedimentation control and operation and maintenance of stormwater best management practices; and
3. If full compliance with the Standards cannot be achieved, they are implementing the highest practicable level of treatment.



9.06: continued

(f) Compliance with the Stormwater Management Standards set forth in 314 CMR 9.06(6)(a) to the extent that they are applicable in accordance with 314 CMR 9.06(6)(b), (c) and (d) does not relieve a discharger of the obligation to comply with all applicable Federal, State and local laws, regulations, and permits including without limitation all applicable provisions of 310 CMR 10.00, 314 CMR 3.00, 314 CMR 4.00, 314 CMR 9.00, local land use controls adopted to comply with 310 CMR 22.21 or the NPDES General Permit for Small Municipal Separate Storm Sewer Systems, and the terms and conditions of NPDES General Stormwater Permits such as the Construction General Permit and the Multi-Sector General Permit.

(7) No discharge of dredged or fill material shall be permitted in the rare circumstances where the activity meets the criteria for evaluation but will result in substantial adverse impacts to the physical, chemical, or biological integrity of surface Waters of the Commonwealth.

(8) Notwithstanding the provisions of 314 CMR 9.06(1) through (7), the Department may allow a project which will restore or otherwise improve the natural capacity of any wetland or other water of the Commonwealth. Such projects include, but are not limited to, dam removal, salt marsh restoration, stream restoration, nutrient management, control or removal of aquatic nuisance vegetation, or vegetation management to improve wildlife habitat.

9.07: Criteria for the Evaluation of Applications for Dredging and Dredged Material Management

(1) General.

(a) No dredging shall be permitted unless appropriate and practicable steps have been taken which will first avoid, and if avoidance is not possible then minimize, or if neither avoidance or minimization are possible, then mitigate, potential adverse impacts to land under water or ocean, intertidal zone and special aquatic sites. No dredging shall be permitted if there is a practicable alternative that would have less impact on the aquatic ecosystem. An alternative is practicable if it is available and capable of being implemented after taking into consideration; costs, existing technology and logistics in light of overall project purposes, and is permissible under existing federal and state statutes and regulation.

(b) All applications, except for maintenance projects, shall include a comprehensive analysis of practicable alternatives as defined in 314 CMR 9.07(1)(a). The scope of alternatives to be considered shall be commensurate with the scale and purpose of the proposed activity, the impacts of the proposed activity, and the classification, designation and existing uses of the affected wetlands and waters in the Surface Water Quality Standards at 314 CMR 4.00.

(c) Dredging and dredged material management shall be conducted in a manner that ensures the protection of human health, public safety, public welfare and the environment.

(d) Applications submitted to the Department shall meet the criteria and performance standards of 314 CMR 9.07. If the project submitted by the applicant does not meet a particular provision of 314 CMR 9.07 and criteria of 314 CMR 4.00, the applicant shall demonstrate to the Department's satisfaction that the project will provide an equivalent level of environmental protection.

(e) Dredged material shall not be disposed if a feasible alternative exists that involves the reuse, recycling, or contaminant destruction and/or detoxification. An evaluation of whether such an alternative is feasible shall consider:

1. the volume and physical characteristics of the dredged material;
2. the levels of oil and/or hazardous materials present within the dredged material;
3. the relative public health and environmental impacts of management alternatives; and
4. the relative costs of management alternatives.

(f) The Department may consider any additional information including but not limited to that submitted under MEPA or NEPA on impacts from the dredging activity, management of the dredged material, the alternatives available for reuse or disposal techniques, alternative sites for the various management activities, or information related to other Department programs.

9.07: continued

- (g) Dredged material management activities or facilities subject to the 401 Water Quality Certification, shall comply with the provisions of 314 CMR 9.00 and the conditions of the 401 Water Quality Certification. The Certification does not relieve the proponent of the obligation to comply with all other applicable federal, state and local statutes and regulations.
- (h) Dredged material, including sediment, placed on or in the land at an upland location is subject to the release notification requirements and thresholds of 310 CMR 40.0300 and 40.1600 for soil, unless such placement is in accordance with the provisions of 310 CMR 40.0317(10) and 314 CMR 9.07 (4), (6), (9), (10), or (11).
- (i) No dredging is permitted for the impoundment or detention of stormwater for purposes of controlling sedimentation or other pollutant attenuation. Dredging may be permitted to manage stormwater for flood control purposes only where there is no practicable alternative and provided that best management practices are implemented to prevent sedimentation or other pollution. No dredging is permitted for the impoundment or detention of stormwater in Outstanding Resource Waters.
- (j) No dredging shall be permitted in the rare circumstances where the activity meets the criteria for evaluation but will result in substantial adverse impacts to the physical, chemical, or biological integrity of waters of the Commonwealth.
- (k) No dredging shall be permitted in Outstanding Resource Waters, except for the following activities specified in this paragraph, which remain subject to an alternatives analysis and other requirements of 314 CMR 9.07:
1. Projects conducted or approved by public or private water suppliers in the performance of their responsibilities and duties in compliance with applicable laws to protect the quality of the water in the watersheds, or to maintain, operate and improve the waterworks system;
  2. Activities determined by the Department to be for the express purpose and intent of maintaining or enhancing the resource for its designated use, after consultation with the entity, if any, with direct control of the water resource or governing water use;
  3. Maintenance, repair, replacement or reconstruction but not substantial enlargement of existing and lawfully located structures or facilities including buildings, roads, railways, utilities and coastal engineering structures.
  4. Maintenance dredging necessary to support or enhance existing water-dependent uses.
  5. Improvement dredging necessary to support or enhance the enlargement of structures or facilities for water-dependent uses is allowed in the following limited circumstances:
    - a. in an Outstanding Resource Water that is designated for purposes other than public water supply; or
    - b. in an Outstanding Resource Water located within an Area of Critical Environmental Concern if the Department determines that the enlargement of structures or facilities for water-dependent uses is consistent with a resource management plan for the ACEC that has been adopted by the municipality and approved by the Secretary.
- (l) Notwithstanding any other provision of 314 CMR 9.07, the Department may allow a project which will restore or otherwise improve the natural capacity of any wetland or other water of the Commonwealth. Such projects include, but are not limited to, dam removal, salt marsh restoration, stream restoration, nutrient management, control or removal of aquatic nuisance vegetation, or vegetation management to improve wildlife habitat.

(2) Sampling and Analysis Requirements. The applicant shall submit the results of all relevant sampling with the application, unless an alternative schedule is specifically authorized by the Department in writing. As part of sampling and analysis, the applicant shall perform a “due diligence” review to determine the potential for the sediment proposed to be dredged to have concentrations of oil or hazardous materials, as defined in 310 CMR 40.0000. Such a review may include, but is not limited to, an analysis of records of the local Board of Health, Fire Department, and/or Department of Public Works, the Department’s Bureau of Waste Site Cleanup, knowledge of historic land uses, information on prior dredging projects and discharges of pollutants in the project area watershed. Sampling that was conducted in accordance with the MCP as a part of site assessment activities or a remedial action shall be supplemented as necessary to comply with 314 CMR 9.07. Supplemental sampling, if necessary, shall be submitted with the application as results or as a sampling plan.

9.07: continued

Applicants for dredging projects proposing unconfined open water disposal shall comply with the sampling, testing, and evaluation requirements and procedures of the U.S. Army Corps of Engineers and U.S. Environmental Protection Agency. A copy of the Determination of Suitability for unconfined disposal shall be provided to the Department.

Unless a project is specifically exempted by the Department from the requirement for chemical analyses, sampling and analysis for upland reuse or disposal of dredged material, as set out in 314 CMR 9.07(2)(a), shall be carried out as follows:

NON-TEXT PAGE

9.07: continued

(a) No chemical testing shall be required if the sediment to be dredged contains less than 10% by weight of particles passing the No.200 U.S. Standard Series Testing Sieve (nominal opening 0.0029 inches), and if the required “due diligence” review demonstrates, to the Department’s satisfaction, that the area is unlikely to contain anthropogenic concentrations of oil or hazardous materials.

(b) In all other instances, chemical and physical testing shall be conducted and the information provided in writing to the Department. When characterizing dredged material, the applicant shall:

1. Consider available analytical information from prior dredging projects conducted at, or locations proximal to, the area proposed to be dredged.
2. Select sampling locations in a manner that ensures that representative information is obtained about the volume, potential contamination, grain-size distribution and total organic carbon of the sediment to be dredged.
3. Evaluate and delineate areas of potentially elevated contamination, based on proximity to outfalls, tributaries, industrial discharges or sources, boat-maintenance activities or historical spills of oil or hazardous materials. In such areas, samples shall not be composited but analyzed separately.
4. For projects up to 10,000 cubic yards, one core for every 1000 cubic yards of dredged material shall be collected. Up to three cores may be composited to create a single sample, provided:
  - a. The grain-size distribution and likelihood of contamination are similar based on depositional characteristics, spill history, and location of point source discharges;
  - b. Cores are composited from the same reach; and
  - c. Samples collected for analysis of volatile compounds are obtained from an individual core and not composited from multiple cores.

For all projects, a minimum of two representative samples shall be characterized physically and chemically.

5. For projects over 10,000 cubic yards, the applicant shall develop a project-specific sampling and analysis plan, taking into account the likely requirement for the alternative(s) being considered for management of the dredged materials. This plan shall be submitted in draft form to the Department for review and comment as part of the pre-application process.

6. At a minimum, sediment shall be analyzed for the following parameters unless specifically exempted by the Department:

Parameter <sup>1</sup>	Reporting Limit mg/kg (dry weight) – unless otherwise noted <sup>2</sup>
<i>Arsenic</i>	0.5
<i>Cadmium</i>	0.1
<i>Chromium</i>	1.0
<i>Copper</i>	1.0
<i>Lead</i>	1.0
<i>Mercury</i>	0.02
<i>Nickel</i>	1.0
<i>Zinc</i>	1.0
<i>Polycyclic Aromatic Hydrocarbons (PAHs)</i>	0.02
<i>Polychlorinated Biphenyls (PCBs)-by NOAA Summation of Congeners</i>	0.01
<i>Extractable Petroleum Hydrocarbons</i> <sup>3</sup>	25
<i>Volatile Organic Compounds (VOC)</i> <sup>4</sup>	0.1
<i>Total Organic Carbon</i>	0.1%
<i>Percent Water</i>	1.0%
<i>Toxicity Characteristic Leaching Procedure</i> <sup>5</sup>	As applicable
<i>Grain Size Distribution – wet sieve (ASTM D422)</i>	Sieve Nos. 4, 10, 40, 60, 200

<sup>1</sup> The applicant shall use the results of the due diligence review to determine whether additional parameters should also be analyzed.

## 9.07: continued

- <sup>2</sup> *If one or more of the Reporting Limits could not be met; the applicant shall include a discussion of the reason(s) for the inability to achieve the reporting limit (e.g., matrix interference).*
- <sup>3</sup> *Current method for the determination of Extractable Petroleum Hydrocarbons (EPH) MADEP January 1998*
- 4 *Required for sediment to be reused or disposed of in the upland environment unless the due diligence review indicates that VOC contamination is unlikely to be present.*
- 5 *Required to be performed when sediment is to be managed in the upland environment and if the total concentrations of metals or organic compounds are equal to or greater than the theoretical concentration at which TCLP criteria may be exceeded: As > 100 mg/kg, Cd > 20 mg/kg, Cr > 100 mg/kg, Pb > 100 mg/kg, Hg > 4 mg/kg.*

7. The Department may allow or require, at its discretion, analyses for additional parameters not listed in 314 CMR 9.07(2)(b)6. when dredging is proposed to be performed in areas where current or historic uses indicate that such contaminants are likely to be present.

8. The chemical analyses of sediment, included as part of an application for dredging, shall have been performed within three years of the date of submission of the application.

9. At the Department's discretion, the project proponent for an aquatic disposal facility may be required to perform a biological assessment of the dredged materials to determine whether there is the potential for the inadvertent transfer of an "invasive species" from the dredging area to the disposal location.

(3) Dredging Performance Standards. Dredging shall be planned and conducted to minimize short-term, long-term, and cumulative impacts on the aquatic ecosystem and to provide protection to human health.

(a) The resuspension of silt, clay, oil and grease and other fine particulate matter shall be minimized to protect aquatic life and other existing and designated uses of waters of the Commonwealth.

(b) Improvement dredging activities shall minimize and, to the maximum extent possible, avoid affecting areas of ecological importance including but not limited to vegetated wetlands, shellfish habitat, spawning habitat, habitat of state-listed rare wildlife, salt marsh, intertidal zone, riffles and pools, and vegetated shallows.

(c) Where feasible, a minimum of 25-feet shall remain unaltered between the edge of vegetated wetlands, salt marsh or vegetated shallows, and waterward edge of the top of the slope of the dredging area.

(d) Dredging shall not be undertaken during migration, spawning or juvenile development periods of finfish, shellfish, crustaceans or merostomatans in locations where such organisms may be affected, except as specifically approved by the Department. Restricted time periods for dredging, or in-water sediment management, will be established by the Department after consultation with Massachusetts Division of Marine Fisheries or Division of Fisheries and Wildlife. Any applicant proposing to dredge during the recommended restricted time period must demonstrate to the Department's satisfaction that measures to minimize impacts (*e.g.*, dredging in the dry, the use of silt curtains, *etc.*) will be sufficient to avoid adverse effects to the species of concern. The Department may consider use of a mixing zone to achieve compliance with Surface Water Quality Standards. Any mixing zone shall be as small as feasible, and site-specific conditions, including, but not limited to depth, currents, and the presence of fisheries and other resources, will determine the mixing zone for any specific project. Within the mixing zone the minimum criteria for chronic toxicity may be exceeded, but the minimum criteria for acute toxicity shall not be exceeded. All water quality criteria apply at the boundary of the mixing zone. The Department may prohibit use of a mixing zone as it deems necessary to provide a reasonable margin of safety for critical uses of waters, *e.g.*, public water supply intakes, shellfish harvesting areas in Class SA and SB waters, wildlife sanctuaries, habitats of endangered species and species of special concern, and/or in Areas of Critical Environmental Concern (ACEC).

(e) In evaluating the potential effects of suspension of contaminated sediment on aquatic organisms, the Department may compare the bulk sediment chemistry with recognized guideline values (*e.g.*, Long *et al.* (1995), Ingersoll *et al.* (2000), *etc.*). The Department reserves the right to request additional sampling and analyses to evaluate the effects of suspension of contaminated sediment on aquatic organisms and/or water quality.

9.07: continued

(4) Intermediate Facilities. Placement of dredged material at an intermediate facility shall be governed by the 401 Water Quality Certification under 314 CMR 9.07(4) unless waived in writing by the Department. The Department may impose specific conditions to ensure that activities at these facilities are conducted in compliance with these requirements:

(a) Dredged material shall be placed in a secure manner to minimize exposure to humans and the environment, and activities shall be carried out in a manner that does not create a nuisance or a threat to public health or the environment.

(b) All activities shall minimize runoff and soil loss through erosion. Any runoff or erosion that does occur shall be remediated and corrective action and/or additional controls shall be immediately implemented to prevent future occurrences. If other permits or approvals are required to conduct the remediation and/or corrective action, then those must be obtained.

(c) Unless approved by the Department, dredged material contaminated above RCS-1 criteria, as defined in 310 CMR 40.0933 and 40.1600, which is stored for more than 24 hours at the site shall be placed in watertight containers or entirely on a base composed of an impermeable material. The dredged material shall be immediately covered with the same material or other suitable material so as to minimize the infiltration of precipitation, volatilization of contaminants, and erosion. Any cover material used shall be properly secured and possess the necessary physical strength to resist tearing by the wind. Any failure of materials or procedures used in the base layer or cover layer shall be immediately repaired, replaced, or re-secured so as to minimize precipitation infiltration, volatilization, and erosion or runoff of the dredged material.

(d) An Intermediate Facility shall not be located:

1. within a Current Drinking Water Source Area or a Potential Drinking Water Source Area as defined in 310 CMR 40.0006;
2. within a 500 foot radius of a Private Water Supply Well as defined in 310 CMR 40.0006;
3. less than ¼ mile upgradient of a surface drinking water supply as defined by groundwater flow or surface water drainage;
4. less than 250 feet downgradient of a surface drinking water supply as defined by groundwater flow or surface water drainage;
5. within 500 feet of a health care facility, prison, elementary school, middle school or high school or children's pre-school, licensed day care center, senior center or youth center, excluding equipment storage or maintenance structures;
6. where traffic impacts from the facility operation would constitute an unacceptable impact to the public, taking into consideration the following factors:
  - a. traffic congestion,
  - b. pedestrian and vehicular safety,
  - c. road configurations,
  - d. alternate routes,
  - e. vehicle emissions, and
  - f. other environmental impacts related to traffic.
7. where it would have a permanent adverse impact on Endangered, Threatened, or Species of Special Concern listed by the Natural Heritage and Endangered Species Program of the Division of Fisheries and Wildlife, an Ecologically Significant Natural Community as documented in writing by the Natural Heritage and Endangered Species Program, the wildlife habitat of any state Wildlife Management Area, or an ACEC;
8. in a location where the anticipated emissions from facility operations would not meet required state and federal air quality standards or criteria or the Department determines that it would otherwise constitute an unacceptable risk to the public health, safety or the environment, taking into consideration:
  - a. the concentration and dispersion of emissions,
  - b. the number and proximity of sensitive receptors, and
  - c. the attainment status of the area.

(5) Transportation.

(a) All dredged material, when transported upon public roadways, shall have no free liquid as determined by the Paint Filter Test or other suitably analogous methodology acceptable to the Department and be covered to minimize fugitive dust (unless transported in vehicles specifically designed to haul liquid materials).

9.07: continued

(b) Truck tire and undercarriage washing (or equally effective mitigation measures) shall be employed to minimize tracking of sediment onto public roadways. Such activities shall be performed in a manner that avoids siltation into wetland resources.

(c) Dredged material shall be transported using a Dredged Material Tracking Form (DMTF) available from the Department. The Dredged Material Tracking Form, or reproduction, shall accompany each shipment of dredged material transported from the dredging site and shall be retained by the entity to whom the 401 Certification is issued for a minimum of five years from the date of transport. The Department reserves the right to impose additional requirements on the transportation of dredged material if the Department determines that such materials represent a hazard to health, safety, public welfare or the environment. The DMTF shall contain the following information:

1. the address or location of the area dredged and the address of any Intermediate Facilities where the dredged material was stockpiled, stored, treated and/or consolidated prior to transport;
2. the name, address and telephone number of the entity to whom the 401 Certification has been issued;
3. the name and address of the transporter;
4. the name and address of the receiving facility or location;
5. the volume of dredged material that will be shipped to the receiving facility;
6. the original dated signature of a Qualified Environmental Professional attesting that the dredge material as characterized, conforms with permitting and regulatory requirements for acceptance at the receiving facility or location;
7. the original dated signature of an authorized representative of the entity to whom the 401 Certification was issued certifying the accuracy and completeness of the shipping document;
8. upon completion of all shipping activities, the original dated signature of a representative of the receiving facility or location, attesting to the total volume or weight of dredged material received by the facility or location; and
9. any other information determined necessary by the Department.

(d) Use of a Dredged Material Tracking Form shall not be required when the dredged material requires shipment:

1. Using a Hazardous Waste Manifest pursuant to 310 CMR 30.000; or
2. Using a Bill of Lading under 310 CMR 40.0030.

(e) In the case where the dredged material is transported in whole, or in part, by barge, a Barge Tracking Form (available from the Department) shall also be required and shall be retained by the entity to which the 401 Certification is issued for a minimum of five years.

(f) Any barge used shall be the best reasonably available marine design and in good operating condition so that minimal discharge of sediment or water occurs during transport to the authorized disposal location(s). Deck barges shall not be used unless the barge has been modified to provide for complete containment of the sediments and written approval has been obtained from the Department.

(6) Beach Nourishment. All projects designed to nourish beach, dune or near-shore areas of land under ocean, utilizing dredged-sediment as source material, shall be carried out in accordance with the Best Management Procedures for Beach or Dune Nourishment and any procedures developed by the Massachusetts Office of Coastal Zone Management and in accordance with M.G.L. c.131, § 40 (the Wetland Protection Act) and relevant portions of 310 CMR 10.00 and M.G.L. c. 91 and 310 CMR 9.00 and M.G.L. c. 132A and 302 CMR 5.00. Right of public access shall be provided for beach nourishment projects on private beaches where public funds are utilized for the activities. Dredged material placed in accordance with this provision shall not be a solid waste and is not subject to 310 CMR 16.00 and 310 CMR 19.000.

(7) Unconfined Open Ocean Disposal. Applicants for dredging projects proposing unconfined open water disposal at designated disposal sites shall comply with sediment and water quality sampling, biological testing, and evaluation according to the requirements and procedures of the U.S. Army Corps of Engineers and U.S. Environmental Protection Agency. The Department may include specific conditions related to time-of-year disposal restrictions to protect the Right Whale or other relevant requirements consistent with the Massachusetts Clean Water Act or other state statutes.



9.07: continued

(8) Confined Disposal.(a) General.

1. Aquatic disposal of dredged sediment that is unsuitable for open ocean disposal shall include management techniques to isolate the sediment from the surrounding environment thereby minimizing potential adverse impacts to the benthic and pelagic communities. The principal methods to isolate the material are to cap it with a layer of "clean" material (Confined Aquatic Disposal) or use of a containment structure (Confined Disposal Facility). Capping may be required for both interim and final controls.

2. In determining the acceptability of a site for a confined disposal facility, the Department will consider all relevant factors including, but not limited to: hydrology and hydrodynamics of the site, existing sediment (physical and chemical quality) at and proximal to the site, protection of marine and wetland resources, recreational activities and unique site factors and conditions. No confined disposal facilities and/or confined aquatic disposal cells shall be located in Special Aquatic Sites or Areas of Critical Environmental Concern.

3. No confined disposal facilities and/or confined aquatic disposal cells shall be permitted unless appropriate and practicable steps have been taken which will first avoid, and if avoidance is not possible then minimize, or if neither avoidance or minimization are possible, then mitigate, potential adverse environmental impacts. No confined disposal facilities or confined aquatic disposal cells shall be permitted if there is a practicable alternative that would have less impact on the aquatic ecosystem. An alternative is practicable if it is available and capable of being implemented after taking into consideration; costs, existing technology and logistics in light of overall project purposes, and is permissible under existing federal and state statutes and regulation.

4. All applications proposing confined disposal facilities and/or confined aquatic disposal cells shall include a comprehensive analysis of practicable alternatives as defined in 314 CMR 9.07(1)(a). The scope of alternatives to be considered shall be commensurate with the scale and purpose of the proposed activity, the impacts of the proposed activity, and the classification, designation and existing uses of the affected wetlands and waters in the Surface Water Quality Standards at 314 CMR 4.00.

5. The siting, operation and post-closure maintenance of confined disposal facilities and/or confined aquatic disposal cells shall be conducted in a manner that ensures the protection of human health, public safety, public welfare and the environment.

(b) Placement.

1. Sediment shall be placed into the facility in a manner that minimizes the escape and release of sediment to the environment. The Department may require water quality monitoring during placement and/or disposal activities to demonstrate that the activities comply with applicable water quality standards.

2. Sediment placement shall occur only during specific periods of time authorized by the Department in writing to provide maximum dilution but minimal dispersion and transport of fine contaminated sediment during placement operations. If an alternative technology is approved that allows the material to be placed directly in the disposal cell without passing through the water column, disposal may occur at any time.

3. Adequate time shall be provided to allow the sediment to properly consolidate prior to placement of the cap to minimize the escape of sediment from confinement during cap placement. Unless specifically approved by the Department in writing, capping of any cell shall be completed within one month of the start of cap placement.

4. The applicant shall provide the Department with a written schedule of activities related to initiation and completions of the capping phase.

(c) Confined Aquatic Disposal (CAD).1. Design Standards.

a. The applicant shall take vessel traffic (e.g. passage of tugboats or deep draft vessels) into account during cell filling to minimize entrainment of sediment from propeller-wash.

9.07: continued

b. Unless specifically exempted by the Department in writing or in regulations, the applicant shall use a water quality model to assess compliance with water quality standards and to determine if restrictions on volume or timing of disposal events are required (e.g., tidal stage, tidal current, disposal volume, multiple disposal event timing, and proximity in time to scheduled vessel passage).

c. If project sequencing allows, the most contaminated material shall be placed at the bottom of cells to allow for the greatest level of sequestering.

d. The disposal cell cap shall be constructed and placed in a manner that minimizes disturbance of the dredged material in the disposal cells and the Applicant shall provide the following:

i. Documentation of the placement of the capping material including the amount and location of each load.

ii. Documentation of the paths of the disposal vehicle to determine where the following load should be placed (if multiple loads are required) to keep the cap thickness as even as possible until the required thickness is achieved.

iii. Surveys of each capped cell to verify that the required areal coverage and vertical thickness is achieved.

iv. Cap material shall be placed wet.

v. Tugs shall be used to move deeper draft self-propelled vessels to minimize prop-wash effects.

vi. There shall be no mechanical disturbance of the cap by a drag bar, clamshell bucket, barge spudding or other means, unless approved by the Department.

vii. The applicant shall assure that at least 90% of the CAD surface area shall include a "clean layer" whose vertical thickness contains at least 70% sand or other approved capping material. Layers comprised of less than 70% sand will be considered a "zone of mixed material" (interface layer) and will not be considered in the determination of capping compliance.

2. Monitoring.

a. If subaqueous cells are utilized, bathymetric surveys shall be conducted prior to cell excavation, after the cell is excavated and constructed, after the disposal of dredged material, and after the cap is placed.

b. Baseline conditions of general water quality, as well as specific contaminants determined to be in the dredged material to be disposed of, shall be assessed prior to the start of any dredging or dredged material placement activities.

c. Each disposal event shall be documented in writing, including the date, time and source of dredged material; the time and location of disposal (including high accuracy location coupled with orientation of the disposal vessel); the equipment used to dredge and dispose of the material; the weather and sea conditions; and personnel on duty. In addition, an estimate of the volume of material disposed shall be provided. Detailed, step-by-step requirements for filling cells shall be developed and utilized.

d. The applicant shall obtain cores from a statistically valid number of disposal cells one year and five years after cells have been capped, selected according to a random distribution among all cells, to evaluate the cap thickness and interface layer, unless alternative times are specified by the Department, to determine the long-term integrity and thickness of the cap material and overlying sediment.

e. Recolonization of benthic species on the surface of the cell shall be assessed against reference site(s) one year after completion of the project, unless an alternative time is specified by the Department. The results of the assessment shall be submitted to the Department in writing within 30 days of it being complete.

(d) Confined Disposal Facilities (CDF).

1. Design Standards.

a. The facility shall be designed and constructed to allow for stormwater controls and material dewatering and the applicant shall evaluate the need for leachate controls, including a liner system.

9.07: continued

- i. Stormwater controls shall prevent erosion, reduce the discharge of pollutants, and protect the physical integrity of the facility. The controls shall be designed to prevent flow onto the active portion of the facility and control the run-off from the active portion of the facility for at least the water volume resulting from a 24-hour and 25-year storm. The Department may require evaluation of a different level storm event due to the nature of the dredged material and/or potential discharge to sensitive receptors (*e.g.*, ORWs, ACECs).
  - ii. The operator shall provide sufficient stormwater drainage controls and diversion structures to promote drainage from the facility, minimize drainage onto the facility, and prevent ponding on or adjacent to the CDF area. Stormwater drainage structures shall be designed, constructed and maintained so as to ensure their integrity;
  - iii. In a situation where significant settlement, ponding of water or erosion occurs during the operation, closure or the post-closure period, the operator or owner shall immediately institute corrective actions and mitigation. If other permits or approvals are required to conduct the corrective action, then those must be obtained.
2. The operator shall prevent the development of vermin, insects, dust, odors and other nuisance conditions.
  3. The operator of facilities located in proximity to airports shall operate and maintain the facility in a manner to ensure that the facility shall not pose a bird hazard to aircraft.
  4. The operator shall provide sufficient fences or other barriers to prevent unauthorized access to the facility
- (e) The facility shall include a final cover system, which shall: minimize the percolation of water through the final cover into the fill material, promote proper drainage of precipitation, minimize erosion of the final cover, facilitate the venting and control of gas (if applicable), ensure isolation of the sediment from the environment, and accommodate settling and subsidence of the facility so that the final cover system continues to operate as designed.
- Unless authorized by the Department in writing, the final cover system shall have a final top slope of not less than 5% and the final side slopes no greater than three horizontal to one (3:1) vertical, and shall be constructed:
1. so as to minimize erosion of all layers of the final cover by using terraces or other appropriate stormwater controls as set out in the Department Stormwater Management Handbooks Volumes One and Two; and
  2. so that the low permeability layer is protected from the adverse affects of frost or freeze/thaw cycles; and
  3. to maintain slope stability.
- (f) The final facility cap shall be designed and constructed: to remain impervious for the expected life and post-closure period of the facility; have a minimum compacted thickness of 18 inches; be compacted to minimize void spaces; to be capable of supporting the weight imposed by the post-closure use without excessive settling or causing or contributing to the failure of the low permeability layer; and to be free of materials that, because of their physical, chemical or biological characteristics, may cause or contribute to an increase in the permeability of the low permeability layer or otherwise cause a failure of the low permeability layer.
- (g) An operation and maintenance plan, subject to the Department's review and written approval, shall be developed and implemented, including a narrative description of operation and maintenance requirements or activities proposed to be conducted during the life of the facility (including the post-closure period) and a proposed schedule for regular inspections and maintenance of the facility, including standard operating procedures.
- (h) The owner or operator shall hire an independent professional engineer, knowledgeable and experienced in matters of containment structures, who shall oversee the installation and construction of all components of the containment structures and certify in writing all design and as-built plans for the facility.
- (i) Siting Criteria. A CDF shall not be located:
1. within 500 feet of an occupied residential dwelling, health care facility, prison, elementary school, middle school or high school or children's pre-school, licensed day care center, senior center or youth center, excluding equipment storage or maintenance structures; unless the applicant shows a valid option to purchase the business or facility within the restricted area, the exercise of which shall be a condition of any Certification;

9.07: continued

2. where traffic impacts from the facility operation would constitute an unacceptable risk to the public, taking into consideration the following factors
  - a. traffic congestion,
  - b. pedestrian and vehicular safety,
  - c. road configurations,
  - d. alternate routes,
  - e. vehicle emissions; and
  - f. other environmental impacts related to traffic.
3. where it would have an adverse impact on Endangered, Threatened, or species of Special Concern listed by the Natural Heritage and Endangered Species Program of the Division of Fisheries and Wildlife, an Ecologically Significant Natural Community as documented by the Natural Heritage and Endangered Species Program or the wildlife habitat of any state Wildlife Management Area.
4. in a location where the anticipated emissions from facility operations would not meet required state and federal air quality standards or criteria or the Department determines that it would otherwise constitute an unacceptable risk to the public, taking into consideration:
  - a. the concentration and dispersion of emissions,
  - b. the number and proximity of sensitive receptors, and
  - c. the attainment status of the area.

(9) Shoreline Placement and Upland Material Reuse Under a 401 Certification. In accordance with a 401 Certification pursuant to 314 CMR 9.07 the Department may permit:

- (a) Shoreline Placement of dredged material at a location proximal to the dredging activity that lies within the 100-year floodplain or buffer zone as defined in 310 CMR 10.00 which ever is greater. Proposals to reuse dredged material shall comply with the regulatory standards of 310 CMR 10.00 and 310 CMR 9.00. Material reuse may include, but is not limited to, use as fill behind bulkheads, or to maintain or improve existing filled areas.
- (b) Upland Placement of dredged material in any upland area as fill or for other reuse activities, provided the concentrations of oil and hazardous material in the dredged material are less than the S-1 soil standards applicable at the receiving location as specified in 310 CMR 40.0975, that the material is not otherwise a hazardous waste and will not adversely affect an existing public or private potable water supply, provided that:
  1. The material is not reused at a location(s) where:
    - a. the nature of the contaminants (evaluated as chemical families such as metals, PAHs, petroleum hydrocarbons, halogenated volatile organic compounds, halogenated pesticides, PCBs, and dioxin-like compounds) in the dredged material is different than that at the receiving location; and
    - b. the concentration(s) of oil and hazardous materials in the soil at the receiving location are significantly lower than the levels of those oil and hazardous materials present in the material;
  2. The material is taken to a site within a designated port area as defined in 310 CMR 9.00 where practicable.
  3. The material is dewatered prior to transportation from the site of dredging and any Intermediate Facilities to the reuse location;
  4. The material is managed, transported, and placed at the receiving location in compliance with the requirements of 314 CMR 9.07;
  5. The Department has not determined in writing that either because of the nature of the proposed activity, the amount of the material, and/or the characteristics of the material that the material requires management as a solid waste subject to the provisions of 310 CMR 16.00 and/or 310 CMR 19.000; and
  6. The applicant provides the following information with the 401 Water Quality Certification application:
    - a. for the property at which the dredge material is proposed to be reused:
      - i. the name and address of the owner of the property,
      - ii. the name and address of the person proposing to reuse the material , if different than the owner of the property,
      - iii. the address of the property, and
      - iv. a United States Geological Survey Topographic Map showing the location of the property.

9.07: continued

- b. a description of the proposed reuse for the material, including but not limited to, the volumes and schedule for the activity;
- c. a physical and chemical characterization of the material and the soil at the receiving location within and adjacent to the footprint of the proposed area where the material is to be placed;
- d. a statement of certification signed by the applicant and the owner of the property at which the dredge material is proposed for reuse that the reuse of the material complies with the provisions of 314 CMR 9.07(9) and 314 CMR 9.07; and
- e. Documentation that the Board of Health of the community(ies) within which the property(ies) are located that the dredged material is proposed for placement has been notified in writing of the proposal.

(c) Reuse under a Dredged Material Reuse Decision at any upland area not authorized under 314 CMR 9.07(9)(a) or (b), provided the applicant obtains a prior written approval of dredged material reuse from the Department, which complies with the following requirements and conditions:

1. Submittal and Criteria Requirements. An application for a Dredged Material Reuse Decision (DMRD) shall be submitted to the Department, and a copy of the application shall be filed with the board of health of jurisdiction, unless the Department determines in writing that the proposed use is not limited to a specific location and therefore it is not practical to identify the board of health with jurisdiction. The application shall contain at least the information indicated in 314 CMR 9.07(9)(c) 2.a. through h.; and the proposed reuse shall comply with the criteria and requirements in 314 CMR 9.07(9)(c)3.a. and b.
2. Application Requirements. Each application shall contain at a minimum:
  - a. a description of the proposed use;
  - b. chemical and physical characterization of the dredged material as defined in 314 CMR 9.07(2);
  - c. the proposed method of handling and utilization of the dredge material;
  - d. identification of the quantity, quality and source of the material;
  - e. a description of any risk management techniques being considered, including any deed or other use limitations, location restrictions, best management practices or engineering controls;
  - f. identification of the proposed location of use, if applicable, or types of locations where the dredge material will be used (*e.g.*, highway rights-of-way, industrial zoned properties, *etc.*);
  - g. a U.S.G.S. 7.5 minute topographic map or smaller scale equivalent map clearly marking the locations of the beneficial use activities; and
  - h. such additional information as the Department deems necessary and appropriate to evaluate and permit the proposed processing and dredge material reuse.
3. Approval Criteria and Requirements. Compliance with the Approval Criteria can be achieved by demonstrating that release and exposure pathways are adequately controlled through the use of risk management procedures (*e.g.* engineering controls; use limitations, *etc.*) If adequate control of such pathways cannot be demonstrated, a reuse specific assessment is required, as described in 314 CMR 9.07(9)(c)3.b.i. or ii. Compliance with the Criteria has been achieved if no concentration of any hazardous material is greater than the Upper Concentration Limit as described in 310 CMR 40.0996 and conditions specified in either 314 CMR 9.07(9)(c)3.b.i. or ii. are met:
  - a. The concentrations of oil and/or hazardous materials are not significantly above background, as determined by a statistically valid and appropriate background concentration sample data set of Massachusetts soils or by a reuse location-specific determination of background; or
  - b. No concentration of oil and/or hazardous materials contained in, or likely to be released as a result of the use of, the dredge material, as appropriate, exceeds acceptable limits as demonstrated using one of the following approaches:

9.07: continued

- i. Numerical Standards Approach. Oil and/or hazardous material concentrations may not exceed applicable standards and guidelines as stipulated by DEP. If an appropriate DEP standard or guideline does not exist for all constituents in all relevant media, then a guideline may be proposed by the applicant developed using protocols consistent with those used in the derivation of existing DEP standards and guidelines for that medium. In addition to the standards and guidelines, the applicant shall demonstrate that the reuse will not lead to exceedances of the Massachusetts Drinking Water Quality Standards at 310 CMR 22.00; Massachusetts Air Quality Standards at 310 CMR 7.00; Massachusetts Contingency Plan Method 1 Standards at 310 CMR 40.0970 applicable to the reuse location; Massachusetts Surface Water Quality Standards at 314 CMR 4.00 and alterations of wetland resources areas in violation of 310 CMR 10.00.
  - ii. Total Waste Reuse Risk Approach. Using this approach, Total Waste Reuse cancer and non-cancer risks shall be determined as follows:
    - Total cancer risks and non-cancer risks shall be calculated for all appropriate exposure pathways and receptors.
    - The assessment shall be performed in a manner consistent with scientifically acceptable risk assessment practices as detailed in guidance published by the Department.
    - A condition of no significant risk to human health has been achieved if:
      - No Exposure Point Concentration of any hazardous material is greater than applicable public health or environmental standards; and,
      - Total Waste Reuse Risk (the aggregate risk attributable to oil and/or hazardous materials) results in excess lifetime cancer risk of less than one-in-one hundred thousand and a noncancer cumulative hazard index of less than one.
  4. Public Safety and Welfare. A level of no significant risk to public safety and welfare exists or has been achieved if the use of the dredged material will not pose a threat of physical harm or bodily injury to people and will not create nuisance conditions, including, but not limited to, noxious odors and noise, in the foreseeable future.
  5. Environment. A level of no significant risk of harm to the environment exists, or has been achieved, if there is no indication of the potential for biologically significant harm (at the subpopulation, community, or system-wide level), either currently or for any foreseeable period of time, to environmental receptors considering their potential exposures to the dredge material.
  6. Property Owner Notification. The Applicant shall prepare and record, when required by this or other permit term or condition, a record in the Registry of Deeds, Land Court, or other permanent record approved by the Department that shall:
    - a. Provide notice to holders of any interest(s) in a property or a portion thereof (including without limitation, owners, lessees, tenants, mortgagee, and holders of easement rights) of the existence and location of the dredge material at such property and the conditions for continued beneficial use and ultimate disposal, if applicable;
    - b. Outline management options if removed, modified, or processed during its lifecycle to prevent adverse impacts and significant risks to public health, safety and the environment, including, but not limited to, nuisance conditions and public welfare impacts; and,
    - c. Provide reference to the Department DMRD application file by including the permit application transmittal number and file location.
- Dredged material, when managed in accordance with provisions 314 CMR 9.07(9) (a),(b) or (c), shall not be considered solid waste for the purposes of 310 CMR 16.00 and 310 CMR 19.000 and its management shall not be considered disposal, unless the Department determines in writing that due to the chemical or physical characteristics of the dredged material or the nature of the activity and/or the amount of the material that the dredged material is a solid waste.

9.07: continued

(10) Management of Dredged Material at Disposal Sites Pursuant to M.G.L. c. 21E and 310 CMR 40.0000, the Massachusetts Contingency Plan.

(a) The dredging, management, and placement of dredged material generated at a disposal site at which response actions are being conducted pursuant to 310 CMR 40.0000, the Massachusetts Contingency Plan, shall be performed pursuant to the provisions of 310 CMR 40.0000 and 314 CMR 9.00. A copy of the remedial action plan under 310 CMR 40.0000, *e.g.*, Immediate Response Action Plan, Release Abatement Measure Plan, Remediation Implementation Plan in which the activity is being conducted and the appropriate transmittal form shall be included with the application for the 401 Water Quality Certification, unless specifically exempted by the Department in writing or in these regulations.

(b) The dredging, management at an Intermediate Facility, and placement at a Confined Disposal Facility or Confined Aquatic Disposal Facility of dredged material generated at a disposal site as part of a remedial action pursuant to 310 CMR 40.0000 shall also be subject to the provisions of 314 CMR 9.00 and a 401 Water Quality Certification. In addition, dredged material generated at a disposal site as part of remedial action under 310 CMR 40.0000 shall be managed in accordance with 310 CMR 40.0000, including but not limited to the provisions of 310 CMR 40.0030.

(c) Dredged material containing oil and/or hazardous materials and that is not otherwise a hazardous waste may be brought from another location to a disposal site and utilized as part of a comprehensive remedial action pursuant to section 310 CMR 40.0800 of the Massachusetts Contingency Plan, provided that:

1. The material is dewatered prior to transportation to the disposal site;
2. The material is not reused at a location where:
  - a. the nature of the contaminants (evaluated as chemical families such as metals, PAHs, petroleum hydrocarbons, halogenated volatile organic compounds, halogenated pesticides, PCBs, and dioxin-like compounds) in the dredged material is different than that at the receiving location; and
  - b. the concentration(s) of oil and hazardous materials in the soil at the receiving location are significantly lower than the levels of those oil and hazardous materials present in the material;
3. It has been demonstrated that it is not feasible to reduce or approach the level of oil or hazardous material at the site of reuse to background in accordance with 310 CMR 40.850;
4. The reuse of the material does not extend beyond the boundary of the area of contaminated soil at the disposal site;
5. The reuse of the material does not result in a condition of Significant Risk as defined in 310 CMR 40.0000;
6. The material substitutes for a material that is otherwise required for and integral to the remedial action at the disposal site unless otherwise authorized by 314 CMR 9.07(c);
7. Unless otherwise approved by the Department in writing, the remedial action is conducted under a Phase IV – Remedy Implementation Plan developed pursuant to 310 CMR 40.0870 that provides for the use of the material at the disposal site.
8. The material is taken to a 21E site within a designated port area as defined in 310 CMR 9.00 where practicable.

(11) Management of Dredged Material Under the Solid Waste Regulations Pursuant to 310 CMR 16.00 and 19.000. Dredged material placed at upland locations other than under 314 CMR 9.07(6), (9) and (10) shall be managed subject to provisions of the Solid Waste Regulations at 310 CMR 16.00 and 19.000 and relevant Guidelines and Policies.(12) Applicability of M.G.L. c.21C and 310 CMR 30.000, the Massachusetts Hazardous Waste Regulations. Dredged material when temporarily stored at an intermediate facility pursuant to 314 CMR 9.07(4), or when placed in confined disposal pursuant to 314 CMR 9.07(8) shall not be subject to regulation as a hazardous waste under 310 CMR 30.000, provided it is managed in accordance with the following:

- (a) the material is managed in accordance with requirements established in a Clean Water Act (33 U.S.C. 1344) § 401 certification, specifically covering the intermediate facility or the confined disposal; and

9.07: continued

(b) the material is managed in accordance with requirements included in a permit issued under § 404 of the Clean Water Act, specifically covering the intermediate facility or the confined disposal;

(c) this exemption shall not apply:

1. to any facility or activity that is not subject to regulation under § 404 of the Clean Water Act;
2. to any facility or activity for which 401 certification requirements have been waived by the Department;
3. to any facility or activity regarding which all 401 certification requirements established by the Department have not been included in a 404 permit; or
4. if the Department determines that compliance with some or all of the provisions of 310 CMR 30.000 is required.

(13) Interstate Management.

(a) Dredged Material from Out-of-state Waters. An applicant proposing to manage dredged material from out-of-state waters pursuant to permits issued for Massachusetts facilities which are proposed to handle dredged material shall file a notification on a form available from the Department. Any out-of-state applicant proposing to dispose, manage, or use dredged material in Massachusetts shall contact the Department to discuss the project prior to the submittal of permit applications.

(b) Dredged Material Going to Out-of-state Management Facilities. An applicant proposing to use or dispose of dredged material originating in Massachusetts at an out-of-state location shall demonstrate to the Department that this alternative is approved by the receiving State. Documentation shall include:

1. evidence that acceptance of the dredged material by the facility complies with the requirements of the receiving state, which may consist of either:
  - a. letter from the appropriate regulatory agency of the receiving state approving receipt of the dredged material, or
  - b. copies of the relevant portions of the facility's permit;
2. evidence that the dredged material has been characterized and meets the facility's acceptance criteria; and
3. written documentation that the receiving facility has agreed to accept the dredged material.

(14) Certification Requirements. The Department may incorporate into its Certification requirements and conditions for each milestone in the dredging process, which shall be performed by the project proponent. Documentation of the fulfillment of the requirements and conditions for each milestone (*e.g.*, quality assurance/quality control plan, liner installation requirements, cap construction) shall be prepared by a Qualified Environmental Professional and submitted to the Department.

(15) Post-closure Use. No person shall use a dredged material placement facility site permitted under 310 CMR 9.07(9) for any purpose other than that established in the 401 Certification after closure without first obtaining Department approval.

(16) Financial Responsibility for Closure, Post-closure and Corrective Actions. The owner or operator of a dredged material placement or disposal facility may be required to establish or obtain, and continuously maintain, financial assurance that is adequate to assure the Department that the owner or operator is at all times financially capable of complying with the provisions of 314 CMR 9.00 governing the closure of the facility and its post-closure maintenance.

9.08: Variance

The Commissioner may issue a variance of the criteria for evaluation of applications under 314 CMR 9.06 or 9.07 if the applicant demonstrates that:

- (1) All reasonable measures have been proposed to avoid, minimize, and mitigate adverse effects on the environment; and



## 9.08: continued

(2) The variance is justified by an overriding public interest or necessary to avoid a certification that so restricts the use of property as to constitute an unconstitutional taking without compensation.

The applicant may file an application for a variance with the Commissioner of the Department stating the proposed measures to avoid, minimize, and mitigate adverse effects and evidence of an overriding public interest or unconstitutional taking. If after public notice the Commissioner finds that the activity meets the variance criteria, the Commissioner shall specify which regulation(s) has been waived and what conditions must be met for certification. The Commissioner may consolidate variance decisions under 314 CMR 9.00, 310 CMR 10.36 and 10.58, and 310 CMR 9.21. Publication of the variance application in the Environmental Monitor shall constitute notice to the public and to agencies with acquisition authority of the Department's pending determination.

9.09: 401 Water Quality Certification

(1) The Department will certify in writing to the appropriate federal agency and to the applicant whether or not the proposed project will meet applicable water quality standards and minimize environmental impacts through compliance with 314 CMR 4.00 as implemented and supplemented by 314 CMR 9.00. Certification will be denied if the criteria of 314 CMR 9.06, 9.07, or 9.08 as applicable are not met. The Department shall send copies of the 401 Water Quality Certification or denial concurrently to the conservation commission, any person who submits written comments during the public comment period and any others who submit a written request. The certification or denial will contain:

- (a) the name and address of the applicant, the address of the proposed activity, and the date of the Department's determination;
- (b) the federal permit number, the 401 Water Quality Certification Transmittal Number and the Wetlands Protection Act File Number, if applicable and available;
- (c) a statement that there is or is not reasonable assurance that the activity will be conducted in a manner which will not violate applicable Surface Water Quality Standards at 314 CMR 4.00 as implemented by 314 CMR 9.00 and a statement of reasons if certification is denied;
- (d) any conditions deemed necessary by the Department to insure maintenance or attainment of water quality, minimization of any damage to the environment that may result from the project, or compliance with any applicable provisions of Massachusetts law that the Department is authorized to administer. As a condition of certification of subdivisions or other phased activities, applicants may be required to record a deed restriction which would limit subsequent discharges of dredged or fill material to ensure that the criteria for the evaluation of applications have been applied to a single and complete project, including all components of multi-phased activities;
- (e) the date the work may begin. No activity may begin prior to the expiration of the appeal period or until a final decision is issued by the Department if an appeal is filed;
- (f) a statement that the certification does not relieve the applicant of the duty to comply with any other statutes or regulations;
- (g) notification of the right to request an adjudicatory hearing as described in 314 CMR 9.10; and
- (h) where applicable, other state law determinations or approvals, including but not limited to a Chapter 91 dredging permit under 310 CMR 9.05(2).

(2) Written applications may be made to amend existing, valid 401 Water Quality Certifications and are subject to the Department's review and approval or denial.

(3) Written applications may be made to extend an existing, valid 401 Water Quality Certifications and are subject to the Department's review and approval or denial.

9.10: Appeals

(1) Right to Appeal. Certain persons shall have a right to request an adjudicatory hearing concerning certifications by the Department when an application is required:

- (a) the applicant or property owner;
- (b) any person aggrieved by the decision who has submitted written comments during the public comment period;

9.10: continued

(c) any ten persons of the Commonwealth pursuant to M.G.L. c. 30A where a group member has submitted written comments during the public comment period; and

(d) any governmental body or private organization with a mandate to protect the environment that has submitted written comments during the public comment period.

Any person aggrieved, any ten persons of the Commonwealth, or a governmental body or private organization with a mandate to protect the environment may appeal without having submitted written comments during the public comment period only when the claim is based on new substantive issues arising from material changes to the scope or impact of the activity and not apparent at the time of public notice.

(2) Notice of Claim. Any notice of claim for an adjudicatory hearing must be accompanied by a filing fee as specified in 310 CMR 4.06 and be sent by certified mail or hand delivered to the Department of Environmental Protection, postmarked within 21 days of the date of the certification.

(3) Contents of Claim. Any notice of claim for an adjudicatory hearing must include the following information:

(a) the 401 Certification Transmittal Number and Wetlands Protection Act Number, the name of the applicant and address of the project;

(b) the complete name, address, and telephone number of the party filing the request; the name, address and telephone number of any authorized representative; and, if claiming to be a person aggrieved, the specific facts that demonstrate that the party satisfies the definition of "aggrieved person" found in 314 CMR 9.02;

(c) a clear statement that an adjudicatory hearing is being requested;

(d) a clear and concise statement of facts which are grounds for the proceeding, the specific objections to the Department's written certification, and the relief sought through the adjudicatory hearing, including specifically the changes desired in the final written certification; and

(e) a statement that a copy of the request has been sent by certified mail or hand delivered to:

1. the applicant;
2. for projects in Outstanding Resource Waters, the public or private water supplier where the project is located, the Department of Conservation and Recreation for projects in Areas of Critical Environmental Concern, or other entity with responsibility for the resource;
3. the owner, if different from the applicant;
4. the appropriate regional office of the Department; and
5. the conservation commission of the city or town where the activity will occur.

(4) Coordination of Appeals. The Department may coordinate adjudicatory appeals under 314 CMR 9.00, 310 CMR 10.00, 310 CMR 9.00 or other administrative appeals.

(a) If a final order has been issued pursuant to 310 CMR 10.00, the Department may exclude issues within the jurisdiction of 310 CMR 10.00 at an adjudicatory hearing held under 314 CMR 9.00.

(b) If an adjudicatory hearing has been requested under 314 CMR 9.00, 310 CMR 9.00, 310 CMR 10.00, or another administrative appeal, the Department may consolidate the proceedings.

9.11: Enforcement

Failure to comply with 314 CMR 9.00 or a 401 Water Quality Certification shall be enforced as provided in M.G.L. c. 21, §§ 42 and 44, M.G.L. c. 21, §16A and 310 CMR 5.00.

9.12: Authorization of Emergency Action

In the rare situation where immediate action is essential to avoid or eliminate a serious and immediate threat to the public health or safety or to the environment, a person may act without a certification, provided that the person obtains prior approval of the Department or authorization under M.G.L. c. 131, § 40. Any emergency authorization issued by the Department shall not relieve such person from compliance with other applicable federal, state, and local requirements and approvals, including approval by the Corps of Engineers. The Corps of Engineers' emergency provisions for Section 404 permits are located at 33 CFR 325.2(e)(4).

(1) Any activity subject to the jurisdiction of 310 CMR 10.00 which has been certified as an emergency by a conservation commission conducted in accordance with 310 CMR 10.06, or by the Department under 310 CMR 10.06(5), or is authorized under 310 CMR 10.06(6)(a)4., and any oil or hazardous material "Immediate Response Action" undertaken in accordance with the provisions of 310 CMR 10.06(7), is also authorized under 314 CMR 9.00.

(2) Absent authorization under 310 CMR 10.00, a written request shall be submitted to the Department which describes the location, the work to be performed, and why the project is necessary for the protection of the environment or the health or safety of the public. Emergency approval shall be issued in writing and shall specify the limits of activities necessary to abate the emergency. When the necessity for undertaking the emergency action no longer exists, any emergency action shall cease until compliance with the provisions of 314 CMR 9.00. In any event, the time limit for performance of emergency work shall not exceed 30 days, unless a written extension is approved by the Department. The emergency authorization may require the submission of an application. No work may be undertaken without emergency authorization under M.G.L. c. 131, § 40, M.G.L. c. 91, and M.G.L. c. 30, §§ 61 through 62H, where applicable.

(3) Any activity subject to the jurisdiction of 310 CMR 9.00 which is eligible for authorization by the Department under 310 CMR 9.20 may receive emergency authorization under 314 CMR 9.12, provided that the applicant submits sediment data or other information if requested by the Department.

(4) "Immediate Response Actions" not subject to the jurisdiction of 310 CMR 10.00, which receive oral approval from the Department pursuant to 310 CMR 40.0420(2), or are initiated 24 hours prior to notification and oral approval pursuant to 310 CMR 40.0420(7) and (8), may commence before a written request under 314 CMR 9.12(2) is submitted to the Department, provided the request is made within 24 hours after the Department's oral approval. Once a request for emergency certification has been made pursuant to 314 CMR 9.12(2), work that commenced prior to such filing may continue pending a decision on the request by the Department.

9.13: Effective Date, Transition Rule, and Severability

(1) 314 CMR 9.00 shall take effect on January 2, 2008. Any application submitted to the Department prior to January 2, 2008 shall be considered under the standards and criteria in effect prior to January 2, 2008, including the Stormwater Management Standards as set forth in the Stormwater Policy issued by the Department on November 18, 1996.

(2) Transition Rule. When an applicant has filed a Notice of Intent under M.G.L. c. 131, § 40 prior to March 1, 1995 for which a Final Order is subsequently issued and the planning board approves a definitive subdivision plan pursuant to M.G.L. c. 41, §§ 81K through 81GG or determines that approval is not required based on plans that substantially conform to the Notice of Intent, activities related to a real estate subdivision shall be subject to the substantive standards as previously in effect under 314 CMR 9.00 dated December 31, 1983. Such activities shall be subject to the application provisions of the revised 314 CMR 9.00 effective March 1, 1995, but not including 314 CMR 9.06 through 9.10.

314 CMR: DIVISION OF WATER POLLUTION CONTROL

9.13: continued

(3) Severability. If any provision of any part of 314 CMR 9.00, or the application thereof, is held to be invalid, such invalidity shall not affect any other provision of 314 CMR 9.00.

REGULATORY AUTHORITY

314 CMR 9.00: M.G.L. c. 21, §§ 26 through 53, c. 21A § 14; c.21C; c. 21E; c. 21H; c. 91, §§ 52 through 56; and c. 111, §§ 150A through 150A½.

[Inside – Back Cover]

